

THOMAS HAVEL

REDACTED PERSONNEL FILE

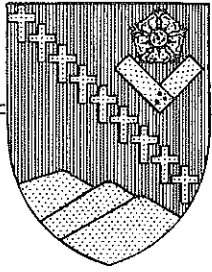

DIOCESE OF SAN JOSE

28 January 1998

Rev. Jack Russi, S.M.
Provincial
Marianist Provincial Offices
P.O. Box 1775
Cupertino, CA 95015-1775

Dear Father Russi,

Bishop DuMaine has asked me to acknowledge your letter of 21 January, regarding the laicization of Father Thomas Havel.

We are grateful for the presence of Marianist brothers and priests and for their rich ministry in this diocese. If there is any way this office might be able to assist you in your ministry, please feel free to call on me.

Know that you are in my prayers.

Sincerely,

Rev. Francis V. Cilia
Interim Director of Clergy Personnel



CONGREGATIO DE CULTU DIVINO
ET DISCIPLINA SACRAMENTORUM

Romae, die 17 Septembris 1997

Prot. N. 1809/97/S

Reverendissime Pater,

die 15 Septembris 1997 huc rite pervenerunt acta processus
administrativi pro dispensatione ab obligationibus sacrae Ordinationis et a votis in favorem
P. THOMAS E. HAVEL presbyteri istius Instituti.

Eadem acta sub n. 1809/97/S in tabulario Dicasterii persignata sunt.

Quam primum ac iuxta proportionata tempora, de eorumdem
pertractatione nuntium habebis.

Quo par est obsequio, me profiteor

In Domino

Reverendissimo Patri

P. ENRIQUE TORRES

Procuratori Generali S.M.

(Via Latina, 22

00179 ROMA)

For your information and files
E.T.

MAR-HAVL 000002

JAMES S. TUCKER, Ph.D.

CLINICAL PSYCHOLOGIST
101 FIRST STREET, SUITE 430
LOS ALTOS, CA 94022-2792

LICENSES: PD-8613, M-14999

Dear friends and clients:

October 17, 1989 was a significant day for Pastoral Services Center and the people we serve. At 5:04 P.M. a 7.1 earthquake caused serious damage to Santa Clara County and to the entire bay area. One of the major losses to the Catholic community was the damage to St. Joseph's College in Los Altos where our offices were formerly located.

Although the collapse of the bell tower and the resultant death received the most attention in the media, the structural damage to the seminary college facility was severe and equally as frightening. There were three staff members in the offices at the time who were seeing patients, viz., Father Havel, Sister Claire and Dr. Doohar. There were also several patients in the waiting room at the time. It was 15 seconds of terror as walls and floors began to crack, fissures developed in structural supports and the rooms filled with the clouds of powdered plaster and concrete. The minutes and hours afterwards were filled with shock as all made their way safely out of the building.

Now that calm has been restored we are operating out of new safe offices provided to us by the Diocese of San Jose. All of us wish to express our thanks to Bishop DuMaine for his concern expressed in making new office space available to us. This period of reorganization provided an opportunity for all of our staff to renew our zeal to offer the highest quality mental health care in a context supportive of Catholic values. The many calls and expressions of concern from our clients during the crisis were deeply appreciated by all of our staff.

As we enter the 1990's we approach our ministry of counseling with hope and enthusiasm. We always welcome your suggestions of how we can better serve your needs. Meanwhile we are back in business stronger than ever and would welcome referral of your family or friends to our service. Thank you.

Rev. James S. Tucker, S.S.

NEW LOCATION: 841 Lenzen Ave., San Jose, Ca 95126-2700

PHONE NUMBERS: Office (408) 925-0225

| | |
|------------------------------|---------------------------|
| Fr. Tucker (408) 925-0225 | Dr. Doohar (415) 826-2925 |
| Dr. Martinez (415) 282-0819 | Fr. Havel (415) 940-7123 |
| Fr. DeMartini (408) 973-9039 | Dr. Bitter (408) 354-4048 |
| Sr. Claire (415) 327-3850 | Emergency (415) 826-2925 |

MAR-HAVL 000003

Miracles and near misses at ravaged St. Joseph Seminary

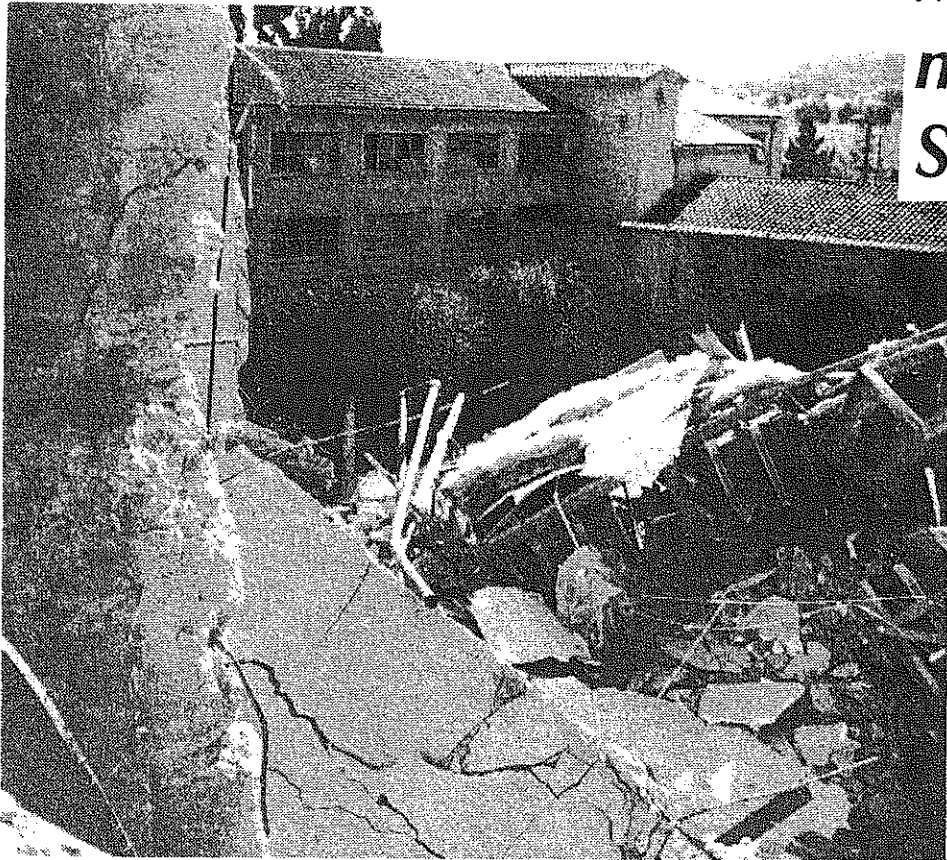

Photo by Roberta Ward

This view of tower's remains was taken from third floor window looking into courtyard.



Square cement piece from fallen tower crashed through several floors and is imbedded in the marble floor in the lobby. . .

Photo by Roberta Ward

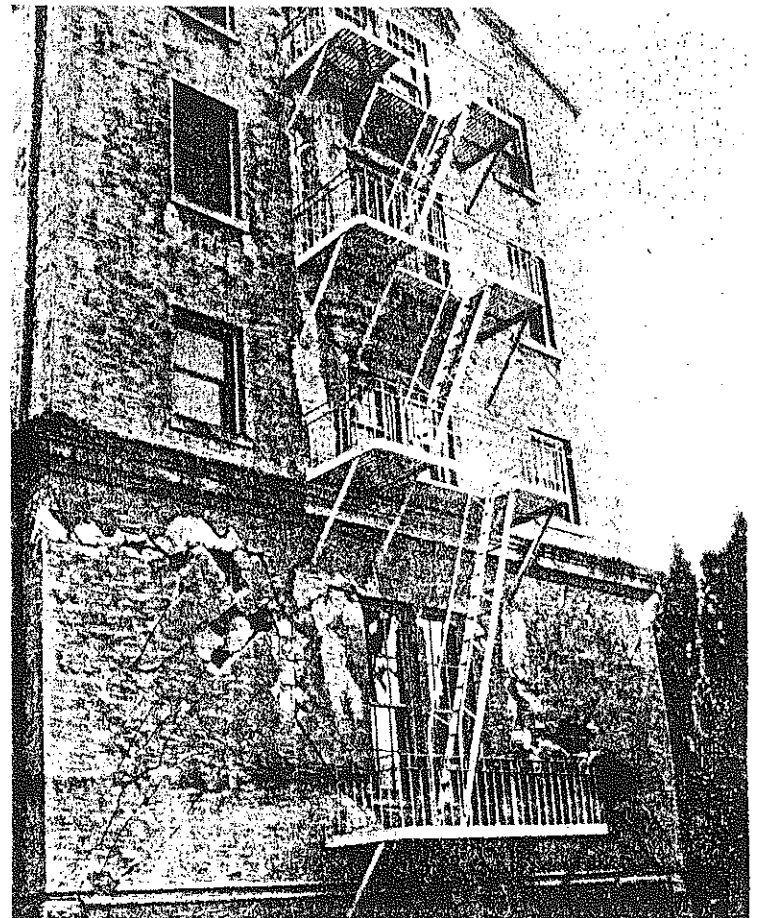

Severely damaged old wing of seminary is completely off-limits. It is split from the new wing and leaning to the west.

Photo by Jim Clark

MAR-HAVL000004

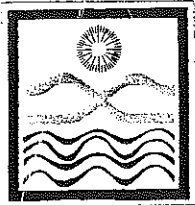

MARIANIST PROVINCIAL RESIDENCE

PROVINCE OF THE PACIFIC

✻ P.O. BOX AC ✻ (22825 SAN JUAN ROAD) ✻ CUPERTINO, CA 95015 - 3026 ✻ PH (408) 253-4841

April 19, 1989

Rev. Thomas Havel, S.M.
10180 Parkwood Drive, #4
Cupertino, CA 95014

Dear Tom,

We have approved your request to continue to live outside of community for one more year. The Council believes that you need more time to work through questions concerning the integration of your life as a Marianist and as a priest and a psychiatrist. We hope that the turmoil created by your present legal battles will soon subside and you will have time to address other more important issues in your life. Please count on our continued fraternal support and prayers.

All of us think it would be a good idea for you to share with Father Timothy Eden the reasons for your present living outside of community. We believe it would be helpful to him to know the reasons why we approved your request.

Fraternally yours,

Father John F. Bolin, S.M.
Provincial

MAR-HAVL 000005

April 5, 1989

Very Reverend John Bolin, S.M.
Provincial, Province of the Pacific
P. O. Box AC
Cupertino, CA 95015

Dear John,

This letter is a follow up on our conversation of March 24, 1989.

I hereby request an extension of my leave of absence from the Society of Mary for one year.

The Purposes of the last year's leave of absence remain the same, i.e., efforts to integrate my life as a Marianist and my work as a psychiatrist. Added to this reason is the confusion resulting from the suit against me which makes my living in community difficult since, at the present time, I feel that I am more of a burden than a support to my fellow brothers.

Thank you for considering this matter.

In Him,



Thomas E. Havel, S.M.

MAR-HAVL 000006

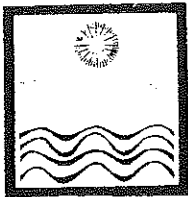

MARIANIST PROVINCIAL RESIDENCE

PROVINCE OF THE PACIFIC

P.O. BOX AC

(22825 SAN JUAN ROAD)

CUPERTINO, CA 95015 - 3026

PH (408) 253-4843

May 24, 1988

Rev. Thomas Havel, S.M.
10180 Parkwood Drive, #4
Cupertino, CA 95014

Dear Tom,

Ordinarily the community of a jubilarian honors the jubilarian with a get-together. Since you have no community, the Provincialate community would be very happy to sponsor a celebration of your silver sacerdotal jubilee. Perhaps you can pick out a date when we could have such a celebration. Bob Juenemann would be very happy to provide the meal and we would be very happy to make arrangements for the Mass, if you want one, and the meal. Whatever you would like, that is what we would try to do. When you get a chance to look at your calendar then you can let me know what you think. One possible date from our point of view would be August 27. I will await your response.

Fraternally yours,

Father John F. Bolin, S.M.
Provincial Superior

MAR-HAVL 000007

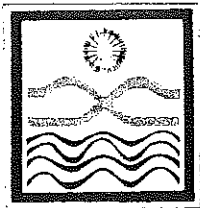

MARIANIST PROVINCIAL RESIDENCE

PROVINCE OF THE PACIFIC

* P.O. BOX AC * (22825 SAN JUAN ROAD) * CUPERTINO, CA 95015 · 3026 * PH (408) 253-4841

May 5, 1988

Rev. Thomas Havel, S.M.
10189 Parkwood Drive, #4
Cupertino, CA 95014

Dear Tom,

On behalf of Provincial Chapter #53 I wish to express to you congratulations on your jubilee and prayerful best wishes. The Chapter is pleased to acknowledge your anniversary and to extend to you the fraternal best wishes of the Province.

To these congratulatory words of the Chapter I would like to add those of the Provincial Administration. We wish you God's blessings and happiness as you celebrate your anniversary.

Fraternally yours,

Father John F. Bolin, S.M.
Provincial Superior

MAR-HAVL 000008

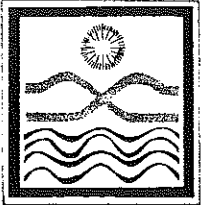

MARIANIST PROVINCIAL RESIDENCE

PROVINCE OF THE PACIFIC

• P.O. BOX AC • (22825 SAN JUAN ROAD) • CUPERTINO, CALIF. 95015-3026 • PH (408) 253-4841

April 8, 1988

Rev. Thomas Havel, S.M.
Marianist Formation Center
22622 Marianist Way
Cupertino, CA 95014

Dear Tom,

I just wanted to put in writing our official approval of your request to live outside of community for one year. Although we have some reluctance about this, we do wish you God's blessings and pray that the time away from community will be a time of growth and renewal.

I hope that in the course of your stay outside of community we will keep in contact as we did the last time.

I would encourage you to be involved in as many Province and local community events as possible during the time of your living outside of community.

God's blessings on you and your work.

Fraternally yours,

Father John F. Bolin, S.M.
Provincial Superior

cc: Father Robert Hughes, S.M.

MAR-HAVL 000009

J. M. J.

March 1, 1988

Very Rev. John Bolin, S.M.
Provincial, Province of the Pacific
P. O. Box AC
Cupertino, CA 95015

Dear John:

With this letter I request permission to live outside community for one year with the possibility of a one-year extension.

Several years ago I had some personal questions about my ability to faithfully live religious life. A two-year leave was given to me at that time. These issues were worked out, and I returned to community life. Now other parallel issues have emerged. I find myself in need of privacy and freedom and how to integrate them into my religious life. They are very important as sources of growth and renewal. I believe that this can best be accomplished by my living outside community by myself.

The work in the apostolate as Medical Director of El Camino Hospital has increased dramatically (new buildings and programs, etc.). This has created added pressures for me. I do not see a way of reducing these pressures (or leaving the job) for the next three years. At that time the new programs will be developed and I can exit gracefully.

The combined demands of community life and apostolate are too much at this time. Consequently, my contributions to community life have suffered. My contributions are inadequate and I do not contribute my fair share to the building of community. The priorities may seem backward and the solution (i.e., living outside community) less than ideal. But I believe it has to be tolerated as a short-term measure.

I have thought and prayed about this decision for the past eight to ten months. I have talked to several people for advice and guidance, including my director, Bob Hughes.

Thank you for considering this request. If granted, I would like to begin April 3, 1988.

Fraternally yours in Christ,

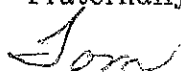

Thomas E. Havel, S.M.

MAR-HAVL 000010

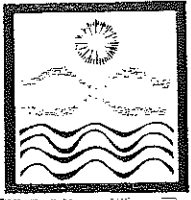

MARIANIST PROVINCIAL RESIDENCE

PROVINCE OF THE PACIFIC

P.O. BOX AC

(22825 SAN JUAN ROAD)

CUPERTINO, CALIF. 95015

PH (408) 253-4841

September 5, 1985

Fr. Thomas Havel, S.M.
Marianist Formation Center
22622 Marianist Way
Cupertino, CA 95014

Dear Tom,

The Provincial Administration, as part of its work for the new apostolic year, would like to study more closely the question of aging and would like to meet with several members of the Province on Sunday afternoon December 15th at 2:00 p.m. at the Provincialate. This invitation is being extended to you, Vinny Steele, Gary Morris and John McEnhill.

We sincerely hope that you will be able to attend this meeting and to share with us your reflections on preparation for retirement, good use of retirement and caring for the sick of our Province, etc.

Please let us know as soon as possible if you will be able to attend this meeting. Thank you very much.

Fraternally yours,

Fr. John F. Bolin, S.M.
Provincial

MAR-HAVL 000011



MARIANIST PROVINCIAL RESIDENCE

PROVINCE OF THE PACIFIC

• P.O. BOX AC • (22825 SAN JUAN ROAD) • CUPERTINO, CALIF. 95015 • PH (408) 253-4841

November 8, 1983

Fr. Thomas Havel, S.M.
770 S. Saratoga Avenue
Apt. T-303
San Jose, CA 95129

Dear Tom,

I am sorry I have to deliver my message to you in this fashion but I think it would be easier if you had the information in writing. I would like very much to get together with you sometime before Christmas. Unfortunately, my schedule is super heavy in the next few weeks. What I was wondering, would it be possible for you and I to get together for supper on either December 1st, 2nd, 3rd or 4th? Any one of those evenings would be fine for me. On the fifth I go to Gardena for my visitation there.

If you find a convenient evening among those listed, please let me know. You can leave a message with Martha if you can't get in contact with me.

Looking forward to an evening together with you. We haven't done that for a long time.

Fraternally yours,

Fr. John F. Bolin, S.M.
Provincial

MAR-HAVL 000012



MARIANIST PROVINCIAL RESIDENCE

PROVINCE OF THE PACIFIC

• P.O. BOX 937 • (22825 SAN JUAN ROAD) • CUPERTINO, CALIF. 95014 • PH (408) 253-4841

February 12, 1980

Very Reverend Joseph M. Stefanelli, S.M.
Provincial, Province of the Pacific
P. O. Box AC,
Cupertino, CA 95015

Very Reverend Father:

With this letter I formally request to make perpetual vows of poverty, chastity, obedience and stability in the Society of Mary for the Province of the Pacific.

I began living in Marianist Communities in 1969 and made my first temporary vows in 1972. Since that time I have lived in two different communities (Gardena and Alcalde Road) and have had the opportunity to know and work with many other Marianists, e.g. in the New York Province while I lived in Washington, D.C. and at the Marianist Studies Program in San Antonio in 1979. I have grown to love the Society, its members, its rule of life and its many works. I feel already permanently committed to the Society in mind and spirit if not yet by perpetual VOWS.

I have had the opportunity to speak often to my spiritual director, as well as, others whom I hold in esteem. All have encouraged me to seek perpetual vows at this time. And I pray that the intentions I have now of living as a son of Mary in her Society will grow stronger with each passing day.

And I hope that you and your council will find me worthy to be perpetually professed as a Marianist in this Province.

Fraternally,

Thomas E. Havel, S.M.

Thomas E. Havel, S.M.

MAR-HAVL 000013

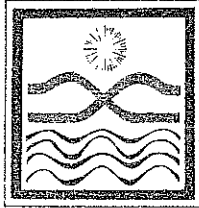

MARIANIST PROVINCIAL RESIDENCE

PROVINCE OF THE PACIFIC

P.O. BOX AC
CUPERTINO, CA 95015
(408) 253-4841

August 12, 1980

Reverend Monsignor John A. Rawden
Chancellor of Archdiocese of Los Angeles
1531 West Ninth Street
Los Angeles, California 90015

Dear Monsignor:

Under date of May 10, 1972, His Eminence had granted a letter of excommunication in favor of Father Thomas E. Havel, who had at that time requested to leave the Archdiocese in order to enter the Society of Mary (Marianists). I wish to inform you, for the record, that under date of August 10, 1980, Father Havel professed his simple perpetual vows as a Marianist religious (Canons 115 and 585).

Sincerely,

Reverend Joseph M. Stefanelli, S.M.
Provincial Superior

MAR-HAVL 000014

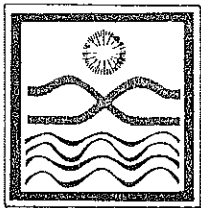

MARIANIST PROVINCIAL RESIDENCE

PROVINCE OF THE PACIFIC

• P.O. BOX 937 • (22825 SAN JUAN ROAD) • CUPERTINO, CALIF. 95014 • PH (408) 253-4841

April 29, 1980

Reverend Thomas Havel, S.M.
Aspirancy Community
22683 Alcalde Road
Cupertino, CA 95014

Dear Tom,

In our recent Council meetings, we reviewed your letter of application for admission to perpetual vows in the Society of Mary, as well as the consultations submitted by your fellow-Brothers. I am happy to be able to inform you that the Council decision was favorable, and I hereby admit you to the profession of final vows. I trust that this decision will bring you much peace and joy, as well as gratitude to God for having called you to serve Him and Our Lady as a Marianist.

I want to congratulate you, too, on the past years of devotedness and service which you so well used to prepare yourself for this next step. If there are any "regrets", it is that perhaps we have not provided you with enough time and opportunity to deepen your understanding of the religious life itself, of the religious life tradition in the Church, and of our own Marianist heritage. But the future is still there, and I know you will take, or make, opportunities to fill in the lacunae and inadequacies that may be present.

There will be a preparatory retreat July 1-21, for the American Provinces. I realize that you have to make your own plans for the immediate future, but the Council urges you if at all possible to free yourself to make this retreat. It will give you a little time to reflect more deeply, to pray, and to prepare yourself more immediately for the public expression of that perpetual commitment which you have already made in your heart.

May God's blessings continue to be evident in your life, and may your love of Mary grow as you understand and enter more fully into her mission of bringing Christ to a world that needs Him so much.

Sincerely,

Reverend Joseph M. Stefanelli, S.M.
Provincial Superior

MAR-AAVL 000015



MARIANIST PROVINCIAL RESIDENCE

PROVINCE OF THE PACIFIC

• P.O. BOX 937 • (22825 SAN JUAN ROAD) • CUPERTINO, CALIF. 95014 • PH (408) 253-4841

13 February, 1980

Fr. Thomas Havel, S.M.
Aspirancy Community
22683 Alcalde Road
Cupertino, Calif. 95014

Dear Tom:

In our most recent Provincial Council meeting, we discussed your request for permission and funding to attend a special studies program in preparation for the psychiatric boards in March of 1980. We approved of your request. We further ask that you contact Bro. Robert Hoppe to work out the necessary details for arranging for the studies in a manner that will be convenient for all parties involved.

Good luck and best wishes for every success.

Sincerely in J.M.J.,

Bro. Edward L. K. Gomez, S.M.
Assistant Provincial

cc: Fr. Allen DeLong, S.M., Director, Aspirancy Community

MAR-HAVL 000016

1

GEORGETOWN UNIVERSITY MEDICAL CENTER • WASHINGTON, D.C.

a postgraduate course in

neurology

under the direction of
Margaret Abernathy, M.D.
Desmond O'Doherty, M.D.
Department of Neurology

— March 17-21, 1980, 8:00 am - 5:00 pm

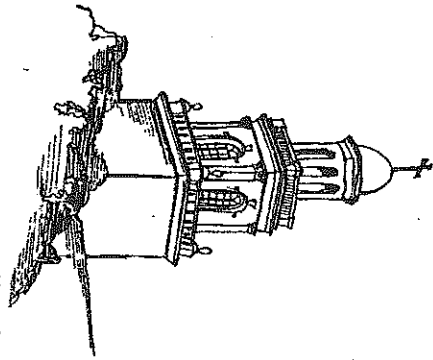

This intensive review of neurology is designed for psychiatrists preparing for written and oral board examinations. In addition to lectures, demonstrations and case discussions, the course will provide opportunities to observe film, live and/or simulated patient examinations. Emphasis will be placed on effective case analysis and presentation, including differential diagnosis.

Topics include: convulsive disorders, cerebrovascular disease, degenerative and demyelinative disorders, infections, neoplasms, neuro-ophthalmology, neuro-otology and neuromuscular disorders. There will be lectures on diagnostic procedures, including EEG, EMG, neuroradiology and spinal fluid examination.

Lectures held in Room L44, Medical Dental Building, Georgetown University Medical Center.

As an institution accredited for continuing medical education, the Georgetown University Medical School certifies that this continuing medical education offering meets the criteria for approximately 40 credit hours in Category I of the Physician's Recognition Award of the American Medical Association, provided it is used and completed as designed.

For further information call Ms. Carol Willard, Course Coordinator (202) 625-7408.

APPLICATION

Concentrated Course — March 17-21, 1980, 8:00 am - 5:00 pm

*TUITION: \$350 payable in advance

Name _____ Phone _____
 Address _____ State _____ Zip _____
 Medical School _____ Degree _____ Year _____
 Make check payable to DEPARTMENT OF NEUROLOGY and mail with this form to:

Margaret Abernathy, M.D., Department of Neurology
Georgetown University Medical Center
3800 Reservoir Road, N.W., Washington, D.C. 20007

Cancellation Policy: A \$25 administrative fee will be retained should you cancel your course reservation. In order to refund the balance, we must receive written notice of withdrawal one week before the course begins.

*Request by T. Havel
for special studies to prepare for
Psychiatric Boards 4/24/80*

Clinical Neurology For Psychiatrists

Parts I and II

Sponsored by The Office of Continuing Medical Education
Albert Einstein College of Medicine

Under the direction of **David M. Kaufman, M.D.**

Courses in New York and Los Angeles designed for Psychiatrists preparing for Parts I and II of the American Board of Psychiatry and Neurology, will consist of lectures, with videotape examples and practice audiovisual examinations.

Part I New York — March 28, 29 & 30, 1980
8:30AM - 5:00PM
The New York Academy of Medicine
Two East 103 Street, New York, NY

Part II Los Angeles — April 11 & 12, 1980
Hotel Bonaventure 5th & Figueroa
9:00AM — 5:00PM

New York — October 4 & 5, 1980
The New York Academy of Medicine

**Part I — (30) Part II — (20) hours of Category I Credit
FOR FURTHER INFORMATION CONTACT**
Office of Continuing Medical Education
Albert Einstein College of Medicine
1300 Morris Park Avenue, Bronx, New York 10461
(212) 430-2822

MAR-HAVL 000017

COURSE DESCRIPTION

This postgraduate course is a clinically oriented, comprehensive review of neurology covering methods of examination, aspects of differential diagnosis and therapy of disorders of the nervous system. Lectures, discussions, and case presentations will be offered by the faculty of the Department of Neurology, The Johns Hopkins Hospital. This course is intended to update a practicing psychiatrist and to provide an excellent view for candidates in preparation for board examinations in neurology and psychiatry.

Schedule

| | |
|----------------------------------|---|
| WEDNESDAY, MARCH 21, 1980 | 7:30- 8:00 a.m. Registration |
| | 8:00- 9:00 Principles of Neurologic Diagnosis Barry Gordon, M.D. |
| | 9:00-10:30 Disorders of Higher Cortical Functions Barry Gordon, M.D. |
| | 10:30-11:30 Principles of Neuro-Diagnostic Testing Fredric K. Cantor, M.D. |
| | 11:30-12:30 Lunch with Faculty |
| | 12:30- 1:30 Demyelinating Disorders Fredric K. Cantor, M.D. |
| | 1:30- 3:00 Metabolic and Nutritional Disorders Robert D. Gerwin, M.D. |
| | 3:00- 4:00 CPC William R. Leahy, M.D. |
| | 4:00- 6:00 Dinner Recess |
| | 6:00- 7:30 Degenerative and Toxic Conditions Alberto Arregui, M.D. |
| | 7:30- 9:00 Cerebrovascular Disorders Kevin N. Hennessy, M.D. |
| THURSDAY, MARCH 22, 1980 | 7:30- 9:00 Seizure Disorders Harvey S. Singer, M.D. |
| | 9:00-10:30 Neuromuscular Disorder John W. Griffin, M.D. |
| | 10:30-11:30 CPC William R. Leahy, M.D. |
| | 11:30-12:30 Lunch with Faculty |
| | 12:30- 2:00 Pediatric Neurology William R. Leahy, M.D. |
| | 2:00- 3:00 Clinicopathological Correlations William R. Leahy, M.D. |

JOHNS HOPKINS FACULTY

- ALBERTO ARREGUI, M.D.
Assistant Professor of Neurology
Johns Hopkins Hospital
- BARRY GORDON, M.D.
Assistant Professor of Neurology
Johns Hopkins Hospital
Baltimore City Hospitals
- JOHN W. GRIFFIN, M.D.
Assistant Professor of Neurology
Johns Hopkins Hospital
- NELSON H. HENDLER, M.D.
Assistant Professor of Neurological Surgery in Psychiatry
and Assistant Professor of Psychiatry
Johns Hopkins Hospital
- KEVIN N. HENNESSY, M.D.
Assistant Professor of Neurology
Johns Hopkins Hospital
- WILLIAM R. LEAHY, M.D.
Assistant Professor of Neurology
Johns Hopkins Hospital
- HARVEY S. SINGER, M.D.
Assistant Professor of Neurology
and Assistant Professor of Pediatrics
Johns Hopkins Hospital

Guest Faculty

- FREDRIC K. CANTOR, M.D.
Assistant Professor of Neurology
Georgetown University Hospital
- ROBERT D. GERWIN, M.D.
Chief of Neurology
Prince George's General Hospital

Registration Information

Date: Friday, Saturday, March 21 & 22, 1980
Time: 7:30 A.M.
Place: Mensana Clinic
 Greenspring Valley Road
 Stevenson, Maryland 21153
Fee: \$185.00 (includes tuition, coffee breaks, luncheons and course outline)
Registration Deadline: March 10, 1980
Refund Policy: Refunds are available until March 7, 1980.
Accreditation: As an organization accredited for continuing medical education, The Johns Hopkins University School of Medicine certifies that this continuing medical education activity meets the criteria for 18 1/2 credit hours in Category 1 of the Physician's Recognition Award of the American Medical Association.
Note: The Johns Hopkins Medical Institutions reserves the right to cancel this course, in which event the full enrollment fee shall be returned to the applicants.
Emergency Calls: A phone will be available in the registration area for emergency calls. Participants can be contacted by calling (301) 653-2403.
For Further Information, Please Contact:

Registration

| | |
|-----------------------------|--------------------------------------|
| Name (please type or print) | Specialty |
| Address | City |
| | State |
| | Zip |
| Day Phone | Academic Affiliation (if applicable) |

Fee: \$185.00 — includes tuition, luncheons and course outline.

I would like to register for the **Neurology Review for Psychiatrists Course**. Enclosed is my check or money order for \$ _____

Registration is limited to 100 persons and March 10 is the final date to register.

Please make check payable to **NEUROLOGY COURSE**, and mail to:

Program Coordinator
 Turner Auditorium
 Room 19
 720 Rutland Avenue
 Baltimore, Maryland 21205

MAR- HAVL 000018

+

July 16, 1979

Very Reverend Charles E. Miller, C.M.
Rector, Saint John's Seminary
5012 East Seminary Road
Camarillo, California 93010

Dear Charley:

It was good to hear from you, although I have periodically been kept informed of "life at St. John's" by George Niederauer.

Your inquiry concerning psychological evaluation of candidates for the seminary interests me very much. It is an area in which I have done some work and hope to do more. And, I agree with you that it would be good to meet concerning this matter.

However there are a few things that I think you should know now. As of August 25, 1979, I will be living in our Aspirancy Community in Cupertino, California for at least the next year. Also, I will not be accepting psychiatric responsibilities for the next eight to twelve months in order to concentrate on priestly, religious and spiritual renewal in preparation for perpetual vows. Finally, I do not do psychological testing; so a testing psychologist would have to agree upon.

None of these is an insurmountable obstacle from my point of view.

I will be in the Los Angeles area from August 14th through August 25th. I would be free to meet you at any time during that period. Or I could come down later after the school year is underway.

I will be in San Antonio until July 31, 1979. Then correspondence should be addressed to
Serra High School
14830 S. Van Ness Avenue
Gardena, California, 90249

It was good to hear from you and I look forward to seeing you in the near future.

Yours in Christ,

Thomas E. Havel, S.M., M.D.

cc: Very Rev. Joseph Stefanelli, S.M. (Provincial)

MAR-HAVL 000019



MARIANIST PROVINCIAL RESIDENCE

PROVINCE OF THE PACIFIC

• P.O. BOX 937 • (22825 SAN JUAN ROAD) • CUPERTINO, CALIF. 95014 • PH (408) 253-4841

May 2, 1979

Reverend Thomas Havel, S.M.
Marianist Community
14830 S. Van Ness Avenue
Gardena, CA 90249

Dear Tom,

We reviewed in Council your application to renew your profession of temporary vows as a Marianist, as well as the community consultation forms. I am happy to tell you that the Council voted favorably on your request, and that I hereby admit you to a renewal of your vows for another year.

I understand from Father Russi that you will be making MSP in San Antonio, and that that program will count as your "official annual retreat". Since Father Russi will also be there, I have asked him to see whether a renewal of vows ceremony might be held during the course of the program and, if possible, while I myself will be there July 5-10.

I want to thank you for all you have done for the community this past year, as Acting Director and as religious. Your interest in all, your personal concern, your evident love for your vocation, are great contributions to the growth of the community. I know you are looking forward to the opportunity next year to delve more closely and more personally into our Marianist roots, and to deepen your own appreciation of your call.

May God's blessings continue to be visible in your life.

Sincerely,

Reverend Joseph M. Stefanelli, S.M.
Provincial Superior

MAR-HAVL 000020

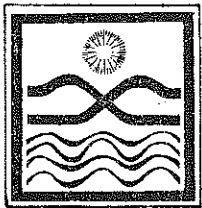

MARIANIST PROVINCIAL RESIDENCE

PROVINCE OF THE PACIFIC

• P.O. BOX 937 • (22825 SAN JUAN ROAD) • CUPERTINO, CALIF. 95014 • PH (408) 253-4841

14 April, 1979

Fr. Thomas Havel, S.M.
Marianist Community
14830 S. Van Ness Avenue
Gardena, Calif. 90249

Dear Tom:

Just a short letter to let you know that the Provincial Council in a recent meeting confirmed your assignment to the Aspirancy Community which will be based at the Alcalde House during the coming academic year. Please contact the Director of the Aspirancy Program, Fr. Allen DeLong to arrange date and time for movement into the new community.

Thank you very much for the many years of service that you have given to the Gardena Marianist Community, especially as Director.

Best wishes and every success for the future.

Sincerely in J.M.J.,

Bro. Edward L. K. Gomez, S.M.
Assistant Provincial

cc: Fr. Allen DeLong, S.M., Director, Aspirancy Program

MAR-HAVL 000021

THE MARIANISTS
JUNIPERO SERRA HIGH SCHOOL
14830 SOUTH VAN NESS AVENUE
GARDENA, CALIFORNIA 90249

March 27, 1979

Very Reverend Joseph M. Stefanelli, S.M.
Provincial, Marianist Province of the Pacific
P. O. Box 937
Cupertino, Ca 95014

Dear Father Joe:

With this letter I officially ask you for permission to renew my temporary vows as a Marianist.

I have consulted my Spiritual Director. And I look forward to my continued service in the Society of Mary.

Since I first came to live with the Marianists nearly ten years ago, I have felt that this is my call and have grown more conscious each year of the special blessings that have been given to me as a Marianist.

I look forward to the coming year as a time of more intense living of the Marianist ideal and a preparation for perpetual vows.

I hope that you and the Council will approve my desire to continue in the Society which has given my life so much meaning.

With the continued blessings of Christ, I hope to continue to strive to live up to the Marianist ideal.

Yours in Christ,

Tom.

Thomas E. Havel, S.M.

MAR-HAVL 000022

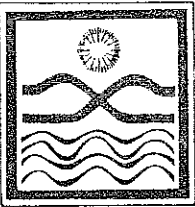

MARIANIST PROVINCIAL RESIDENCE

PROVINCE OF THE PACIFIC

• P.O. BOX 937 • (22825 SAN JUAN ROAD) • CUPERTINO, CALIF. 95014 • PH (408) 253-4841

February 12, 1979

Reverend Thomas Havel, S.M.
Marianist Community
14830 S. Van Ness Avenue
Gardena, CA 90249

Dear Tom,

As you are aware, I will be with your community on official visitation in the middle of March. I plan to drive to L.A., and would arrive in Gardena the afternoon of March 15; I would plan to leave the morning of the 21st. This gives me six full days with your community, which I hope will be enough.

During the time of the visitation, in addition to seeing each religious individually, I would appreciate having two periods of time: for a conference, and for an exchange of questions and comments on matters of Province or local interest. These two periods could be continuous, or at different times, as seems best to you. I would also like to meet with your Community Council, especially if there are matters you would like to bring to my attention for discussion with them. If there are such matters, perhaps you could drop me a note in advance so that I might prepare my reactions and reflections.

I hope all of you are in good health; Brother Henry seems to be getting back on his feet progressively and should be back with you by the time I arrive there. My greetings to all the community, and best wishes for a fruitful Lent.

Sincerely,

Reverend Joseph Stefanelli, S.M.
Provincial Superior

MAR-HAVL 000023

THE MARIANISTS
JUNIPERO SERRA HIGH SCHOOL
14830 SOUTH VAN NESS AVENUE
GARDENA, CALIFORNIA 90248

February 4, 1979

Marianist Provincial Residence
P. O. Box 937
Cupertino, California 95014

The House Council of Serra Community has reviewed all of the forms turned in. No one had any adverse criticism. All had tremendous praise for Father Tom Havel and the leadership he has given to the Serra Community. All members were very happy to hear that Father Havel will be attending the Marianist program in Texas this coming Summer. It will give him a better insight into the Marianist Spirit and background of the Society - more than he has been able to get mostly by his own efforts and readings.

For the members of Serra Community House Council

Bro Leo S. Rausch, S.M.
Bro. Leo S. Rausch, S.M.

MAR-HAVL 000024

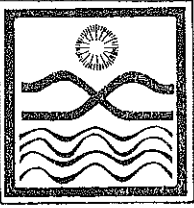

MARIANIST PROVINCIAL RESIDENCE

PROVINCE OF THE PACIFIC

• P.O. BOX 937 • (22825 SAN JUAN ROAD) • CUPERTINO, CALIF. 95014 • PH (408) 253-4841

28 December, 1978

Fr. Thomas Havel, S.M.
Director, Marianist Community
14830 S. Van Ness Avenue
Gardena, Calif. 90149

Dear Father Tom:

This is a brief reflection statement on my recent visitation to your Community in early December. First of all, my earnest thanks to you and to all the Brothers for your ever warm and attentive hospitality. I always enjoy rekindling the many delightful memories of the four years I spent in the Gardena Community in the early 70's.

In general, my impressions of the Community were positive. There did not seem to be any pressing issues yearning to be resolved. Many community members are conscious of some perennial problems (personal responsibility, quality of personal, communal, community presence to mention but two) and each one in his own manner tries to deal with the realities of the situation. Perhaps more & careful group interaction could surface some of the underlying issues.

The commitment of the Archdiocese of Los Angeles to the apostolic work in which the majority of the community members is engaged causes some consternation. Perhaps more candid and in depth dialogue as to the possible future directions that Junipero Serra High might take and the role that Marianists play in the institution might be fruitful.

Finally, a concern for a Director for next year is beginning to make itself known. Hopefully, the Community will be able to devise a process to openly dialogue this issue.

Again, thank you for all that you have done to make my visitation pleasant and fruitful.

Hauoli Makahiki Hou!

Bro. Edward L. K. Gomez, S.M.

MAR-HAVL 000025



MARIANIST PROVINCIAL RESIDENCE

PROVINCE OF THE PACIFIC

• P.O. BOX 937 • (22825 SAN JUAN ROAD) • CUPERTINO, CALIF. 95014 • PH (408) 253-4841

4 December, 1978

Fr. Thomas Havel, S.M.
Marianist Community
14830 S. Van Ness Avenue
Gardena, Calif. 90249

Dear Father Thomas:

As you undoubtedly have noticed on the Provincial Administration calendar, my visitation to the Gardena Community is scheduled to begin on Monday, 11 December. However, I shall probably travel by auto and therefore may arrive sometime during the weekend (Saturday or Sunday). I shall phone ahead to inform you of a precise date and approximate arrival sometime later this week.

During the visitation I would like to have time to interview the members of your community and also to set time aside for a conference. If you or the Community Council or any member of the community are desirous of any other gathering and/or meetings, please schedule same and I shall be happy to accommodate whatever is programmed.

Looking forward to seeing all of you again, I remain,

Sincerely in J.M.J.,

Bro. Edward L. K. Gomez, S.M.

MAR-HAVL 000026



MARIANIST PROVINCIAL RESIDENCE

PROVINCE OF THE PACIFIC

• P.O. BOX 937 • (22825 SAN JUAN ROAD) • CUPERTINO, CALIF. 95014 • PH (408) 253-4841

October 31, 1978

TO WHOM IT MAY CONCERN:

This is to verify that Thomas Havel, Catholic Priest and professed religious, is a member in good standing of the Society of Mary (Marianists), Province of the Pacific (cf. Official Catholic Directory, 1977, p. 1042). This is further to verify that Father Havel has pursued, and is currently pursuing, medical studies with a view to contributing to the Marianist outreach toward the disadvantaged and the poor, as well as providing psychiatric services to priests and religious. These studies have been requested by, and are approved of by, his competent religious superiors.

During the course of these studies, and after their termination, all of Father Havel's expenses are ultimately assumed by the Society of Mary, and all his income, from whatever sources, belongs to the Society according to terms of its Constitutions (art. 25). Father Havel has conscientiously observed these stipulations of the Constitutions, and has faithfully deposited all his earnings in accounts authorized by and subject to the control of his religious superiors in keeping with his profession of religious obedience (cf. Const., arts. 35-38).

Appended is a copy of a Rescript from the Sacred Congregation of Religious and Secular Institutes, of the Vatican, authorizing him to prepare for and to practice medicine according to the norms of Canon Law of the Roman Catholic Church.

If any further clarification of Father Havel's status is required, I will be happy to furnish additional information.

Sincerely,

Rev. Joseph M. Stefanelli S.M.

Reverend Joseph M. Stefanelli, S.M.
Provincial Superior

MAR-HAVL 000027

C O P Y

May 23, 1978

Rev. Thomas Havel, S.M.
Marianist Community
14830 S. Van Ness Avenue
Gardena, Calif. 90249

Dear Tom,

This is an official note to confirm my telephone conversation with you, and to name you (again) Acting Director of the Gardena community. The confidence and support of your community members should be a source of encouragement to you, that they appreciate what you do as Director despite the limitations under which you have to work because of your professional formation program. Your experience these past two years has proven to them and to you that you have the ability and strength for the job, and that your role has been much more than merely "caretaker."

I agree with you that we must look forward to providing adequate leadership for the community in the future. We may, as a Province, have to rethink our approach to the selection of Directors since the present method limits our choices very much, and provides no real possibility of preparing specific persons for such offices.

Be assured of my personal thanks for all you continue to do for the community, and my support for your efforts in the future.

Sincerely,

(Rev.) Joseph M. Stefanelli, S.M.
Provincial Superior

cc Bulletin Bd

MAR-HAVL 000028

May 15, 1978

Rev. Thomas Havel, S.M.
Marianist Community
14830 S. Van Ness Ave.
Gardena, Calif. 90249

Dear Tom,

Your request for admission to a renewal of vows, together with the community evaluation forms and consultation blanks, were reviewed in Council on May 4. I am happy to be able to tell you that the Council voted favorably on your request, and that I hereby admit you to renew your vows for another year. I am sure you are familiar enough with the comments of your Brothers -- their appreciation of your devotedness to the community as Director, of your continuing growth as a Marianist, of your obvious involvement in the life of the community -- together with their regrets that your professional program continues to draw so heavily on your time and your energy.

It is my hope, and theirs, too, that this coming year will see some moderation in the demands of your professional formation, so that you can discover that important "sacred leisure" so necessary for spiritual and religious growth. It will be important, also, to program eventually some additional explicit Marianist studies into your schedule -- perhaps a summer MSP or renewal program. Meanwhile, I am confident you are doing whatever is possible to strengthen your faith life, your religious living, and your dedication to the wellbeing of others.

I want to add my personal thanks for all you do for the community, and for the concern you manifest for each member. May God continue to bless you with strength and health, and the happiness that comes from loving and serving Him.

Sincerely,

(Rev.) Joseph M. Stefanelli, S.M.
Provincial Superior

MAR-HAVL 000029

April 1, 1978

Very Reverend Joseph Stefanelli, S.M.
Provincialate, Province of the Pacific
P. O. Box 937
Cupertino, California 95014

Very Reverend Father:

With this letter I formally request renewal of my vows for one year as a member of the Society of Mary (Province of the Pacific).

I make this request after consultation and approval of my Spiritual Director.

As you know I began to live in Marianist Communities in 1969, make my first profession of vows in 1972 and am presently a member of the Gardena Marianist Community. When I finish my education in 1979, I hope to formulate plans with the Provincial Administration about my future apostolate and to live in other Marianist Communities. With these goals accomplished, I hope, with God's grace, to be received for perpetual vows in a way of life that means so much to me

Yours in Christ,

Thomas E. Havel, S.M.

Thomas E. Havel, S.M.

MAR-HAVL 000030

+

2/6/78

Joe

Br Ken's itenary is as follows.

Chicago until Feb 21st

at Calvert House

5735 University Ave

Chicago, Ill 60637

312 - 288-2311

on weekends

at Walt Niegorski

1204 Stinfield

South Bend Ind 46617

219-234-5157

Feb 21 - 28th

Novitiate.

Dayton Ohio

Returns to Garden 2/28/78

At. 7:10 pm

from T Havel

MAR-HAVL 000031

C O P Y

February 1, 1978

Rev. Thomas Havel, S.M.
Marianist Community
14830 S. Van Ness Avenue
Gardena, Calif. 90249

Dear Tom,

Your letter caught me just before I leave for Hawaii. Thanks for the information on your plans. I talked to Bob Hoppe, and we O.K. your plans for therapy and for the car. Thanks to your folks for their thoughtfulness. Bob will be down your way shortly and you can see him about any further details.

Congratulations on your election to the Provincial Chapter! I only hope it does not place too large a demand on your already tight schedule.

I received nothing definite from Ken on his Chicago - Dayton trip. I would appreciate if you could send me at least the dates of departure and scheduled return.

Best wishes, prayers, greetings to all.

Sincerely,

(Rev.) Joseph Stefanelli, S.M.
Provincial Superior

MAR-HAVL 000032

THE MARIANISTS
JUNIPERO SERRA HIGH SCHOOL
14830 SOUTH VAN NESS AVENUE
GARDENA, CALIFORNIA 90248

January 30, 1978

Very Reverend Joseph Stefanelli, S.M.
Marianist Provincial Residence
P. O. Box 937
Cupertino, California 95014

Dear Joe:

This letter is to formalize the exchange of information and the requests that had been made with various members of the Provincial Administration during their visitations.

First, the ten thousand dollar student loan and its seven percent interest have been paid off by the payment made on January 23, 1978.

Second, with that financial responsibility out of the way, I would like to start psychotherapy. I plan on seeing a psychoanalyst, Dr. Sigmond Gabe, M.D. The cost is sixty dollars per hour. I plan on going twice a week. Later when the time is available the number of session will rise to four times per week. Then the cost will be fifty dollars per session. This is considered a professional expense rather than a medical expense. If I am ever required to pay income tax, it would all be deductible.

Third, I spoke of getting a "new" car. I am still traveling forty five minutes each way to work; so I would like a reasonably heavy and quiet car with air conditioner. My parents are willing to sell a 1975 Chevelle with only 15,000 miles to the Province for three thousand five hundred dollars. Two friends and associates of mine have offered one thousand dollars towards the price of a car; so the cost to the Province would be two thousand five hundred dollars. The Province car that I am presently using has 125,000 miles on it; but it runs well. Possibly it could stay at Serra as a Community car; and they could sell their 1964 Impala which is in rather bad shape.

With regard to the possibility of paying income tax and the signature of a member of the Provincial Administration being on the checking account that I use, I have already started talking to Bob Hoppe, and we will go into it in greater detail during his visitation in February.

I hope this clarifies these issues and is agreeable to you. If there are no objections, I will initiate therapy and the purchase of the car as soon as possible.

In Him,

MAR-HAVL 000033
Tom

Thomas Havel, S.M.

December 29, 1977

Rev. Thomas Havel, S.M.
Marianist Community
14830 S. Van Ness Avenue
Gardena, California 90249

Dear Tom,

This is just a brief follow-up to my visit with your community. I am sorry we did not find more time to reflect together on some aspects of the community life, but your schedule and mine didn't leave much leisure. I will try to indicate here my general impressions.

I found the spirit of the house generally good, positive, and encouraging. All the religious are appreciative of what you do as Director, especially since they realize the burden of professional duties which weighs upon you. Your personal interest in each of them is commendable and is a source of strength in the house. There seems general satisfaction with the community meetings and the functioning of the House Council.

There seem to be still some unresolved undercurrents in the area of community prayer life - presence, choice of singing, adequate preparation. I hope you can help Pat and the Office of Zeal address these areas of community prayer. My own personal impression is that more could be done to help the community "pray" the Hours - choice of readings, adequate pauses for reflection, background information on the psalms, etc. I realize that busy schedules leave little time for this, and that is perhaps the major weakness of the community. Lip service to the priority of community must eventually face the hard realities of priorities and choices. Dedication to various apostolic engagements should overflow from the fullness of community prayer and living, and not be in competition with them. And a strong community life will be the best means of attracting others to share our Marianist life.

I want to encourage you and the community to continue your efforts at community development and at sharing the Marianist presence. We all realize, I am sure, that the community cannot do everything, either for its own growth or in the apostolate; that is why it is so important to constantly review priorities and evaluate means and methods.

May this New Year bring all of you much peace and joy in the Lord.

Sincerely,

(RSE.) Joseph M. Stefanelli, S.M.

MAR-HAVL 000034

C O P Y

3 May 1977

Reverend Thomas Havel, S. M.
Marianist Community
14830 South Van Ness Avenue
Gardena, California 90249

Dear Tom,

No doubt our conversation over the phone about your appointment as Director will rob this letter of any element of surprise, but for the sake of the record: At our Council meetings last week, we reviewed your request for renewal of vows as well as the consultation of the community held on that occasion. I am happy to inform you that you are hereby granted permission to renew your temporary vows for one year, at the time of your annual retreat. If I understood you correctly, this retreat will probably take place sometime in November.

When I see you up here later this month, I will try to share with you some of the comments and reflections of your Brothers, so that their fraternal concern may encourage and support you. May Our Lord continue to bless you and your work, both professionally and in the community.

Sincerely,

Reverend Joseph Stefanelli, S. M.

MAR-HAVL 000035

C O P Y

2 May 1977

Reverend Thomas Havel, S. M.
Marianist Community
14830 So. Van Ness Avenue
Gardena, California 90249

Dear Tom,

Following our Council deliberations and my telephone conversation with you, I am hereby appointing you as Acting Director of the Gardena Community for another year. The work you have done in the past year, and the responsive support of your community, indicate that you are well qualified to fulfill this function. I realize the bind placed upon you by your work schedule, and can only hope, with you, that "next year it will be easier!"

The community will undergo a considerable change in membership over the summer, and I urge you to set aside some "community orientation days" sometime in August when all the members of the community can be present and you can, all together, map out some directions and desiderata for the new 1977-1978 year. I hope to see you up here in Cupertino later this month, and we can at that time give some consideration to how this might best be done. You have in the community, as you well know, a wealth of know-how and experience on which you can draw, to get the community off to a really good start.

I want to thank you for agreeing to assume this responsibility again, and assure you of my support and prayerful remembrance.

Sincerely,

Reverend Joseph Stefanelli, S. M.

cc: Community Bulletin Board

MAR-HAVL 000036

C O P Y

2 April 1977

Reverend Thomas Havel, S. M.
Marianist Community
14830 South Van Ness Avenue
Gardena, California 90249

Dear Tom,

As I had indicated to you at the time Ed and I were visiting your community, I would like to follow up that visitation with a few personal reflections on the community situation as I see it. This is not, therefore, an "official" report, since it is not reviewed in Council; that "official" report is being made at the time of the Provincial Chapter.

In general, I found the community atmosphere very positive, people satisfied, and no one asking to move out! I believe you yourself have been an excellent positive force in the community, despite the necessity of frequent absences because of your work. Members of the community understand why you cannot be there, and are very grateful that you manifest such intense community spirit when you are present. They have regrets, but no criticisms, about your not being able to be more present than you are.

They also appreciate very much your concern for each one, and the time you take to talk to them individually. This is very encouraging, and in some cases has proved a real challenge to a more serious preoccupation with the religious life.

From what I understand, despite some misconceptions on my part at first, your community meetings are well-attended generally, and given to serious considerations. I would encourage this to continue, asking the community to attempt a more profound investigation of certain issues that need to be surfaced: the nature of community prayer life, priorities concerning involvement in the school, attitudes to be taken as Christians and religious on the question of the Teachers' Strike (and the strikers themselves).

MAR-HAVL 000037

Reverend Thomas Havel, S.M.
2 April 1977
Page 2

As you know, and is evident to all, the participation of some members in the communal prayer life leaves much to be desired. The community must continue to deal with this phenomenon, not only in an all-too-easy judgmental sense, but in trying to understand the basic positions of each, and what might be done to help each religious "stretch" a bit to meet the positions of others and to enable the community to find a common position that, while not being merely the lowest common denominator, will enable all to participate more fully in the community prayer life. Perhaps this one issue could occupy a prolonged period of time -- two or three meetings in a row, a week-end "renewal" period, a periodic retreat...

The Offices, from what I could gather, are functioning fairly well, and I commend you and the Heads of the Offices for this. There does seem to be need to share explicitly more about the various apostolates (including studies) in which people are involved, to see how they might be better supported by the community, and to create the atmosphere which will allow a certain amount of non-threatening challenge to take place.

I would like to commend the high school personnel in particular for their evident dedication to the school, and to their interest in that work. As always, a balance must continually be sought between the commitments to the apostolic works, and the responsibilities to the development of community life. This, too, might provide material for some prolonged community consideration, especially as the number of religious available diminishes. Alternative methods of presence in the work should be explored, to effect if possible greater influence with fewer religious -- not easy, I admit, but desirable!

I want to thank you, and the entire community, for the evident spirit of hospitality and friendliness in the house, and for your graciousness to us in particular. May the approaching Easter Season bring much peace and joy to all.

Sincerely,

Reverend Joseph Stefanelli, S.M.

cc: Community Bulletin Board

MAR-HAVL 000038

16 February 1977

Reverend Thomas Havel, S. M.
Reverend Frank Campanella, S. M.
Marianist Communities
California

Dear Tom and Frank,

I am writing this as a joint letter to the two of you, since you will have to collaborate on the matter it presents! As you know, Ed and I have scheduled our southland visitation for March, and I would like at this time to work out some of the details.

Ed will be flying in from the East (Interprovincial Formation Meeting), and I should be driving down from Cupertino, on March 13, Sunday. We plan to return to Cupertino, Saturday, March 26. During the interim, we would like to visit each of your communities, preferably together, and hold three meetings with the community and one with the Council.

The topics of the three community meetings will be: 1) Provincial Administration Goals and Objectives; 2) Overview of the Province; 3) Local concerns and feedback on the visitation. I therefore ask the two of you to work out the details of scheduling these various meetings in ways that are most convenient for you and your community calendars. If Ed and I have to commute back and forth, we will do so. However, generally, we hope to spend at least 5-6 days in each community.

During the course of this visitation, I would also like to see each religious in a personal interview. The scheduling of these interviews will, of course, depend on the calendar of meetings, and I will draw up the interview schedule after I arrive. I would be grateful if I could have the visitation calendar by March 1, when I will be back in Cupertino.

Sincerely,

Reverend Joseph Stefanelli, S. M.

MAR-HAVL 000039

THE MARIANISTS
JUNIPERO SERRA HIGH SCHOOL
14830 SOUTH VAN NESS AVENUE
GARDENA, CALIFORNIA 90249

November 22, 1976

Brother Edward L. Gomez, S.M.
Province of the Pacific
P. O. Box 937
Cupertino, California 95014

Dear Ed;

Re: Kenneth Batinovich assignment to the Gardena S.M. Community

The following statements were discussed and agreed upon by me and the House Council.

1. The Gardena Marianist Community would be most happy to have Ken as a member of our community and would make every effort to make him feel at home.
2. However, we feel that Ken should be exposed to all the forms of the Marianist life style before he and we make a decision about his vocation. Consequently, we feel that he should experience living in other communities of the Pacific Province before he makes his first temporary vows.
3. As of now we have no suggestions to make as to an apostolate that would be of benefit to him and the local Christian Community. Consequently, we feel that the Provincial Administration should spell out in detail Ken's apostolic work while here in Gardena.
4. As of now there is no active formation program for temporary professed here in Gardena. This is a lack that the temporary professed already feel most keenly. We feel that this lack would be even more intensely felt in the special formation needs that Ken might require.

The above statements were agreed upon by the whole House Council. Finally, I would like to raise several questions as a Doctor of Medicine and Resident in Psychiatry. Without the answers to these questions and an authoritative interpretation of them, I do not feel the Provincial Council can render an informed decision concerning Ken's vocation as a Marianist. I would like to give these questions to you when we meet in early December.

Fraternally in Xt,

Tom

(Rev.) Thomas E. Havel, S.M.

MAR-HAVL 000040

C O P Y

October 12, 1976

Reverend Thomas Havel, S.M.
Marianist Community
14830 South Van Ness Avenue
Gardena, California 90249

Dear Tom,

Greetings from Hawaii! This is just a follow-up to some of the items discussed at the Directors' Workshop about our "joint visitation" to your community and to Canoga Park in December.

Ed and I plan to drive down on Saturday, December 4, possibly stopping in Santa Barbara to see Joe Aspell, unless Joe can get to Canoga Park while we are there. We plan to return north December 19 or 20.

During that time, as you know, we would like to speak to your community about the General Chapter (a follow up to what Ed and Dave will have already presented in November), and about the relations of the Provincial Administration with the local community that is, two input sessions. We would also like to have two other sessions with the whole community, to provide opportunity for questions and discussions on those two topics (or any others the Brothers might want to raise). We would also plan a meeting (at least one, more if desirable) with the Community Council to discuss local concerns and ways in which the Provincial Administration might be of service to your Council, your Office, or the community itself.

Since we hope to have a similar schedule with the Canoga Park community during that same period of time, I ask that you get in touch with Father Campanella to work out the calendars of each community in such a way as to avoid conflicts in scheduling. We will be at the disposal of the communities, and will make no other plans until we get the schedules you have drawn up. Ed will also want to see each religious individually, but that schedule can be

MAR-HAVL 000041

C O P Y

Reverend Thomas Havel, S. M.
October 12, 1976
Page 2

worked around the meetings easily enough. While we would of course like to keep the commuting between Gardena and Canoga Park to a minimum, that is not the prime consideration. Schedule the meetings at the times that are most convenient for the two communities, and we will adapt accordingly. As I indicated at the Directors' Workshop, these meetings with the Community are not necessarily in addition to the regular events on the community calendar; they might replace some other community function or spiritual exercise.

I would appreciate it if you and Frank could get your respective (or a joint) schedule to me by mid-November, so we can make our own further plans. We intend to spend most of our time in either community, so as to get a feel for the community life and spirit, and also to be available for the many informal contacts that are sometimes more useful than the formal ones. When you send the schedules, please also indicate which local concerns have surfaced from prior community discussions and which you and the community would like to have us address when we come.

My greetings to all the Brothers, and best wishes for a growthful year.

Sincerely,

Reverend Joseph Stefanelli, S. M.

MAR-HAVL 000042

C O P Y

June 13, 1976

Rev. Thomas Havel, S.M.
Marianist Community
14830 So. Van Ness Ave.
Gardena, CA. 90249

Dear Fr. Tom:

On behalf of Fr. Stefanelli and his Council I wish to express our gratitude and good wishes at your acceptance of the Acting Directorship of the Gardena Community.

I'm sure Fr. Joe mentioned the community consultations showed a great deal of respect for your leadership qualities and for all the time and interest you've shown with your involvement in community life and functions. Welcome to the life of administrators!

Although your term is only one year, and that year usually begins August 15, we would like you to begin June 15 since Bro. Haster is in San Francisco. If you find this difficult due to your summer program we'll understand. For this reason we won't mention any date in PAC and we'll let you break the news to your community in your own fashion.

Be assured of our support and prayers. God bless

Yours in Christ,



Bro. Robert Hoppe, S.M.
Acting Provincial

MAR-HAVL 000043

C O P Y

May 7, 1976

Reverend Thomas Havel, S.M.
Marianist Community
14830 South Van Ness Avenue
Gardena, California 90249

Dear Tom,

In the press of a busy schedule, I am sending you this formal notification that your request for admission to a renewal of temporary vows was reviewed in Council this week. I am happy to inform you that the Council, after studying the consultations received from your fellow religious, has recommended that you be granted this favor you ask. I therefore authorize you to renew your profession of temporary vows, for a period of one year, at the time of your annual retreat.

When I see you personally, I will share with you the major reflections of your fellow Brothers, the positive points they find in you which lead them to recommend your renewal of vows, and the negative points which some of them see as counter-indications of a true Marianist vocation. I am sure that by now most of these comments are known to you, and I encourage you to give them all (positive and negative) your serious attention in order to prepare yourself better for the donation implied in the religious profession. Be assured of my personal best wishes and my prayers, as well as those of the other members of the Provincial Administration, that you may each day correspond more generously and lovingly to the grace God offers you.

Sincerely,

Reverend Joseph Stefanelli, S.M.

cc: Brother John Haster, S.M.

MAR-ANL 000044

MARIANIST PROVINCIAL RESIDENCE

PROVINCE OF THE PACIFIC

P. O. Box 937 Cupertino, California 95014 (408) 253-4841

April 7, 1976

Fr. Tom Havel, S.M.
Gardena Community

Dear Tom,

Due to your tax exempt status with the government and the obligation of the Province to cover students expenses I have revised our agreement of Oct. 5, 1975 concerning financial arrangements.

I. Income: All income will be posted to the Gardena Marianist Community accounts (70-4). The Marianist endorsement is necessary to satisfy government IRS requirements that you're an agent of the Marianist Province of the Pacific (employer).

II. Living Costs: Your room and board (living allowance) is paid to your community by the Province, directly.

III. Other Expenses:

A. A checking account is authorized to meet your unique situation. Both your signature and that of the community treasurer must be on the signature card. This account is a "petty cash" revolving account in the amount of \$500.00. It is both an emergency account to cover expenses demanding instant (less than one day) payment, and funds to cover meals and incidentals outside the community. Accounting for these funds will be made when requesting replenishment.

B. All bills (invoices, subscriptions, etc.) and loan repayments will be paid from the community accounts (70-4).

C. At Dec. 31 and June 20 all "excess" funds in the community account 70-4 will be forwarded to the Province in lieu of assessment. Allowance will be made to leave enough money to meet your immediate loan repayment requirements.

Yours in Christ,

Bro. Robert Hoppe, S.M.
Asst. for Temporalities

cc. Bro. Ed Gomez, S.M.
Bro. John Haster, S.M.
Bro. Mike Oberdin, S.M.

MAR-HAVL 000045

C O P Y

November 19, 1975

Reverend Thomas Havel, S.M.
Marianist Community
14830 South Van Ness Avenue
Gardena, California 90249

Dear Tom,

Enclosed is an Indult from the Holy See for you to practice medicine. When I was in Rome in September, Father Miguel Sanchez-Vega insisted we needed one -- so here it is. Isn't it nice to know you are "legitimate" in the exercise of your professional duties?

I hope all is going well with you, and that you are getting a little rest from time to time. I will be coming south in January and will see you then.

Sincerely,

Reverend Joseph Stefanelli, S.M.

enc.

MAR-HAVL 000046

October 5, 1975

Br. Robert Hoppe, S.M.
Provincial Administration
Province of the Pacific
P.O. Box 937
Cupertino, California 95014

Dear Bob,

As you recall in our conversation of September 22, 1975, it was agreed that the details of handling my finances should be determined on the local level. Consequently, a meeting was held on September 29, 1975. Present at this meeting were Bra. John Haster, Thomas Heinle and myself.

The uniqueness of my present work and the unexpected financial demands made by it from time to time warranted the following decisions.

1. A checking account would be opened in the names of Br. Thomas Heinle and Fr. Thomas Havel.
2. All income from my work would be deposited in this account.
3. The payment of all indebtedness in the form of professional and educational loans (\$9,000.00) will be paid through this account.
4. All professional expenses will be paid from this account.
5. At the end of each month a check will be made out to the Gardena Community to cover the following:
 - a. \$125.00 for board and room for the month.
 - b. the sum of "professional" petty cash expenses
(the sum of this receipt will be recorded in account #70-1)
6. At the end of each month all receipts and disbursements from the checking account will be entered into the house account 70-1.
7. At the end of each month a petty cash account record will be made out which will show the total amount of cash spent in the areas of professional and personal expenses (The latter will be paid by the community.)
8. A petty cash account of \$100.00 will be provided by the community to cover the professional expenses and personal expenses.
9. At the end of each fiscal year the surplus in the account, after professional expenses, personal expenses, community stipends, loan payments, and province assessment have been paid, will be forwarded to the Provincial Administration.

I presented these decisions to Br. Edward Gomez on October 5, 1975. And, at his suggestion, I am forwarding a written account of these decisions.

Sincerely,

Thomas E. Havel, S.M.

copies: Ers. Gomez, Haster, Heinle

MAR-HAVL 000047



DEPARTMENT OF PSYCHIATRY
DIVISION OF GRADUATE EDUCATION

Sherwyn M. Woods, M.D.

Director

Elliott L. Markoff, M.D.

Associate Director

Sept. 30, 1975

Thomas E. Havel, M.D.
14830 S. Van Ness Avenue
Gardena, CA 90249

Dear Dr. Havel:

I am pleased to inform you that we will be able to offer you an appointment as a Postgraduate Physician Year II in Psychiatry (First Year Resident) at the Los Angeles County - USC Medical Center. This appointment currently carries the following monthly stipend:

Postgraduate Physician Year II (1st Year): \$1376.

Postgraduate Physician Year III (2nd Year): \$1491.

Postgraduate Physician Year IV (3rd Year): \$1607.

There is a Southern California Agreement that residency programs will not demand an acceptance less than 14 days from the date of offer. However, if you know earlier that you want the appointment I would appreciate hearing from you. Similarly, in the event that you do not want the appointment I would greatly appreciate notification at your earliest convenience so that the position can be offered to someone on the alternate list. In the event that you decide to accept our residency, be sure that the enclosed agreement is returned in the enclosed envelope by October 15, 1975.

The entire Department joins me in our hope that you will be with us next year. With best regards, I am

Sincerely,

Sherwyn M. Woods, M.D.
Professor

SMW:kt
Enc.

C O P Y

May 18, 1975

Reverend Thomas Havel, S.M.
3729 "T" Street, N.W.
Washington, D.C. 20007

Dear Tom,

Your request to renew temporary vows as a Marianist was reviewed in Council. I am happy to inform you that you are hereby admitted to a renewal of vows for one year. While we are not able to hold a regular "consultation" for this renewal, the evaluations held in the Gardena community earlier in the year were of great help. At the time of the retreat in Honolulu, I will be happy to review with you the comments and suggestion offered by your fellow-Brothers. I am sure you will find it helpful for your own Marianist life, to know how your Brothers see you, what qualities they discern, and also what areas of improvement.

I am sure these days are full ones for you as you prepare for graduation. My personal congratulation, Tom, and prayers. It will be good to have you back within the confines of the Pacific Province soon.

Sincerely,

Reverend Joseph Stefanelli, S.M.

MAR-HAVL 000049

May 12, 1975

Reverend Thomas Havel, S.M.
3729 "T" Street, N.W.
Washington, D.C. 20007

Dear Tom,

Thanks for your letter of May 1, and the news. Congratulations on your graduation, and on being homilist for the occasion. I suspect it is not too often that a graduating Doctor is also a priest; are you perhaps the first at Gerogetown?

I leave May 10 for the UD workshop/retreat on Marianist Purposes in Higher Education. If it were not for having to return for Rodney's ordination, I would like to come to Washington for your graduation -- however, bilocation is not yet a component part of being Provincial. . . I should be here in the Cupertino area the last two weeks of May, and will be going to Honolulu for the retreat, so I am sure we will have occasion to talk over your plans for the future.

Best wishes, prayers.

Sincerely,

Reverend Joseph Stefanelli, S.M.

MAR-HAVL 000050

+

May 1, 1975

Dear Joe,

In just three short weeks it will be all finished (or just beginning depending on how one looks at it)! Just to prove that it is happening, a graduation announcement is enclosed.

These last few weeks have had a few special graduation events. The A. O. A. Honor Society had a dinner. One of the female professors at Georgetown talked for 1 1/2 hours! on the feminist movement. It almost made a male chauvinist out of me! There was a Class Clam Bake (actually steamed — very messy but good with beer). I have been asked to give the homily at the graduation Mass and the benediction at graduation.

There is always great peril involved in a prophet speaking in his own country, but I'm willing to give it a good try.

My parents are flying into D.C. for a week. And "the girls" are giving me a graduation buffet supper for twenty five guests. Hopefully, Joe Yax and a couple of brothers from Baltimore

will be coming down for the graduation. When one has been in school as long as I have, you don't like to make too big a deal about another graduation; but things seem to grow all by themselves.

There is a wedding of a classmate on May 25 at which I will officiate. And then I and a fellow medical student will be heading for San Francisco on May 26th.

I would like very much to see you before I fly to Hawaii on June 2nd, because I would like to propose a slight change of plans as regards to my future. I would like to specialize in General Surgery rather than in Internal Medicine. This offers both a disadvantage (i.e., 1-3 years of extra residency) and several advantages (i.e., ① more versatile health care - a surgeon can learn to treat the usual Internal Medical Problems but the opposite is not true - and ② I feel my talents interests and happiness would be more fulfilled in Surgery). But I would like to talk about it personally, since a letter is not the best form of communication for me.

I have made some preliminary inquiries which have been very encouraging; but

(3)

nothing definite has been proposed.
This change would in no way adversely
affect the present ideas we have shared
concerning a Marianist Health Care Apostolate.
But more of this when I see you.

Enclosed is my expense account for
April. Please forward it to Bob.

My Internship begins on June
24th. I get a months vacation.
And I asked for June 1976; but
I won't know the exact time until
I get on the job.

I was up to Baltimore last weekend
for the province celebration for the
Jubilarians. About half the Province
was there. I had a good time and
felt very inspired by the whole weekend.

Please keep me in your prayers
in these closing days of school.

And I look forward to seeing you all

In Xt,

Tom.

P.S. I'm sorry that I'll miss Rodney's
ordination; but he and all of you will
be in my thoughts & prayers on May 17th



GEORGETOWN UNIVERSITY
SCHOOL OF MEDICINE
WASHINGTON, D. C.

March 10, 1975

Dear Father Stefanelli,

After consulting with my confessor, I hereby request the renewal for one year of the temporary vows of poverty, chastity, and obedience as a member of the Society of Mary.

In 1969 I first came to live the community life of a Marianist. In 1972, attracted by this religious life, their spirit and their apostolate, I first took temporary vows as a Marianist. And each year I happily renewed these vows with the hope that, one day, they will be perpetual vows.

For, just as I believed that Christ and His Mother were then calling me to become a Marianist; so now, with their help, I hope to live the rest of my life as a faithful member of the Society of Mary.

I pray that you and the Council will look favorably upon this request; and, with God's help, that I can be a faithful Marianist for the rest of my life.

In J. M. f.

Thomas E. Havel, S. M.

THE MARIANISTS

14830 SOUTH VAN NESS AVENUE
GARDENA, CALIFORNIA 90249

October 28, 1974

Dear Harry and Joe,

Concerning my plans (immediate and distant), I will list the up coming events and you can use what ever you wish.

I will be in California until February 23, 1975.
From October 14 thru Nov. 8th, I am doing a four week elective in Cardiology at LAC-USC Medical Center.
From Nov 8th until Nov 17th, I will be interviewing with the different Hospitals to which I am applying for internship and residency.
All my applications are for Straight Medical Interaship, i.e. they are the first year of a three year Residency in Internal Medicine, the speciality I think I help the most people with.

The Hospitals I am applying to are: San Francisco General Hospital, Kaiser in San Francisco and in San Jose, Santa Clara Valley Medical Center in San Jose, St. Mary's in Long Beach, Long Beach Memorial ("the Hospital of X-presidents"), LAC-USC Medical Center in L.A., Harbor General in Torrance, VA Hospitals in Westwood and San Fernando Valley, Orange County General Hospital, Riverside General Hospital.
(All are University affiliated programs.)

Then from Nov 18 through December 13th, I have an elective in Physical Medicine at Harbor General Hospital in Torrance,
From Dec 16th thru Jan 10, I return to LAC-USC Medical Center for an elective in Dermatology.

Then I have 6 weeks of vacation. One week will be for retreat. Two weeks vacation, two weeks to show "My little old ladies" around California. and a week to drive back to Wash.

Once back in D.C. I have 4 wks of Emergency Medicine, 4 wks. of Radiology and 6 wks. of Surgery. Then I get my M.D. on May 25, 1975.

My Internship will begin on July 1, 1975.

During my travels through the state, while I am visiting most of the communities in California, I want to take the time both formally and informally to explain what I am doing to the communities and to get their feedback.

This is "where it's at" for me at this time. You can edit this material as you wish. If I can ~~earr~~ clarify anything please let me know.

In Him,

Tom. *Harrel*

MAR-HAVL 000056

PROGRESS NOTES

291437 MOONEY BERNARD
DR ELLISON CATH 2509
6353 64TH AV RIVERDALE MD
9/29/74 #13 P/MED 136424

| DATE | |
|------|---|
| | 10/3/74 |
| | |
| | Dear Joe, |
| | |
| | I leave Sat for Calif. I'm looking |
| | forward to being back in the Provincia. again. |
| | I received a letter from Jack McNeil |
| | in which he told me about his plans & enclosed |
| | a copy of the letter he sent to you. I feel bad |
| | about it - not only because he is leaving; but |
| | also, because I feel after reading his letters, that |
| | <u>he</u> doesn't know the <u>real</u> reasons why he is leaving. |
| | I would like to share more of this with you |
| | when I see you next. |
| | The visit to Dave Schayler was great. |
| | I hadn't spoken much to him before; but so |
| | this was a great chance to know him better. |
| | I think we to can have high expectations for the |
| | P. A. what is the kind of men we have in it. |
| | Enclosed is my expense account. It is |
| | high this month & I be glad to give more |
| | of an explanation if necessary. I expect a |
| | \$2,500.00 loan to come through any day |
| | now. |
| | In X t |
| | Tom |

C O P Y

September 16, 1974

Dr. Thomas E. Havel, M.D.
937 12th Street, Apt. 202
Santa Monica, CA 90403

Dear Dr. Havel,

Thank you for your kind note and the check for \$3,000 toward our Educational Fund. I assure you of my personal gratitude and the appreciation of my Administration for this gift.

I just wrote to Tom a few days ago. Hopefully he will be able to come out this way soon, and I am sure that you and the family will find that considerably more satisfactory than his being in Washington. I was able to visit him there last spring, and we had a good long talk about the future of health care service in the Society of Mary. Your son may turn out to be a real pioneer!

My greetings to Mrs. Havel. I trust you are both in good health.

Gratefully,

Rev. Joseph Stefanelli, S.M.
Provincial Superior

MAR-HAVL000058

T. E. HAVEL, M. D.

937 - 12th STREET, APT. 202
SANTA MONICA, CA 90403

September 11, 1974

Reverend Joseph Stefanelli, S.M.
Province of the Pacific
P.O.Box 937
Cupertino, California 95014

Dear Father Stefanelli:

Enclosed please find a check for \$3000.00 offered
as a donation to your Educational Fund. I hope
that this may help your Fund out. I also hope that
you may continue to do the good work that you are
doing.

Again I wish to thank you for the arrangements
we had while in Rome as it really made our trip.

Yours respectfully,

Thomas E. Havel, M.D.

TEHem

MAR-HAVL000059

C O P Y

September 9, 1974

Reverend Thomas Havel, S. M.
3729 "T" Street, N. W.
Washington, D. C. 20007

Dear Tom,

John Haster was here, of course, for the Directors' Meeting, and told me that you expect to come to the Coast early October. I think that is wonderful, and I say Welcome Back! I am certainly glad you were able to find hospitals in the LA area where you can work.

Perhaps by the time you get this letter, you will already have seen Father Schuyler. I shall not try to come to Baltimore on my trip East next week, because of a very tight time schedule. But I certainly will be seeing you in Gardena.

Your being in Gardena should give you a number of occasions to see Art Gomez and to compare notes on future health care plans. Ray Mooney was here briefly last week. He is scouting around for openings for Physician's Assistant next year after he finishes his studies. I suggested the possibility of Walla Walla, where there are several large hospitals and not too many doctors. We'll see what develops.

MAR-HAVL 000060

C O P Y

Reverend Thomas Havel, S. M.
September 9, 1974
Page 2

I hope your two "mothers superior" do come out to the Coast -- and I promise not to ask them too many scrutinizing questions about your behavior. Best wishes for your studies, and see you in a couple of months.

Sincerely,

Reverend Joseph Stefanelli, S. M.

P.S. Just got yours of the 3rd. Santa Clara Valley Medical has a very good reputation. A whole wing for paraplegics, run by one - also a very good burn unit. I have visited there a number of times and been much impressed. Not a very professional evaluation, of course.

+

SEP -9 ANS'D

Sept 3, 1974

Dear Joe,

I hope all is going well to you. I have a breather for 3 wks working in the Pediatrics out patient Dept for The hours are human (8-5 x 5 d/wk) + the kids are great fun to work with..

I am trying to get some applications off for inter-ships during the coming wks. One of the hospitals that I am applying for is Santa Clara Medical Center in San Jose. If you know anything about it, let me know. I don't know anything about it; I choose it because it was near one of our communities which is the prime motive in all my applications.

I'm about 5 wks I'll be in Calif. I already wrote to John Haster about putting me up at Serra for most of the time. As of yet, I haven't had a reply; but I'm optimistic about staying there.

All my elective time is now scheduled; so I'll be able to stay the whole 4 1/2 months in Calif.

Enclosed is my expense account for August. Please forward it to Br. Charles.

I'm sure that I'll be in your neck of the woods for interviews and for a retreat.. Until then keep me in your prayers.

In Xt,
Tom

MAR-HAVL 000062

C O P Y

July 29, 1974

Reverend Thomas Havel, S.M.
3729 T Street
Washington, D.C. 20007

Dear Tom,

Just a note to acknowledge your letter of July 10. It was good to hear from you, and I was happy to learn that you were able to make a good portion of the retreat. I am glad, too, that you and Ray Mooney were able to compare notes on the future health apostolate. We will have much to discuss and plan, and I hope you will be coming to California soon.

I appreciate and understand your reluctance to participate in the consultation for Assistant Provincial. We are still awaiting official news on the appointment. Father Tutas is due in here tomorrow. Maybe something will materialize soon. Unfortunately, Roger is already in Europe and will not be back for a couple of weeks. He was ready to come at a moment's notice to brief the new man on many phases of the job. As you know, he is working for the Foreign Study League, and living (when he is home) in Los Gatos, so he is not far away--either in geography or in interest.

I checked with the novitiate about your parka. Kevin says it is there, and they will hold it for you unless you want them to send it your way. I thought it best to wait until you know for certain where you will be for the winter. I hope it will be California.

Greetings from all of us out here. I passed you by in flying directly from New York to San Francisco last Saturday, returning from the Over-50 Program.

Sincerely,

Reverend Joseph Stefanelli, S.M.

MAR-HAVL 000063

JUL 29 ANS'D

PROGRESS NOTES

+

July 10, 1974

| DATE | |
|------|---|
| | Dear Joe, |
| | <p>Enclosed please find my expense account for June '74. Please forward it to Br. Charles. Also enclosed is a letter from Dr. Lefevre. I had an exam last February for hypertension. If our insurance covers the laboratory expenses, could Br. Charles forward to him the proper forms? If our insurance doesn't cover the exam, please have him drop Dr. Lefevre a note to that effect.</p> |
| | <p>I received the \$3000.00 from the Province. As of now, I still haven't received information on my student loan. There probably won't be any until Sept.</p> |
| | <p>Roy Moorey was in DC 2 weeks ago. We had a very good talk. And we share many of the same goals in regards to our sharing a health care apostolate. However, he will have to find an intermediate work until I finish my studies.</p> |
| | <p>Your thoughts about an inter-provincial health care apostolate, might receive some impetus when John McGeeth told me about a M.D. who made inquiries about joining their Province. He said that he would keep me informed; but so far no word.</p> |
| | <p>My "retreat" worked out better than hoped. The location was changed at the last moment. And it was held at a retreat house about 20 min</p> |

PROGRESS NOTES

| DATE | |
|------|--|
| | Drive from Georgetown. So, I not only made the last 2 days, but I also went out each evening for the evening vesper, dinner & the night conference |
| | Please thank John Bolin for his kind notes. I hope he will enjoy his new role in S. F. |
| | I did not forward my recommendation for Asst. Provincial because I didn't feel knowledgeable enough about the people being considered & the present needs of the province. I hope you will understand my reluctance to participate at this time. |
| | It was a real shock to hear about Roger. But my prayers & best wishes go with him. |
| | There is still no definite information about my elective courses in Calif. for Oct → Feb. |
| | But when they are firmed up. I'll drop you a note. I'll probably stay at Serra if all goes well. |
| | Please give my regards to all at the provincialate. |
| | In Xt, Tom |
| | P.S. Please ask Charlie Oryabu if he has seen a large blue parka at the Novistas. I think I might have left it there when I visited last Feb. |

C O P Y

May 13, 1974

Reverend Thomas Havel, S. M.
3729 T Street, N. W.
Washington, D. C. 20007

Dear Tom,

It was certainly good of you to come to Baltimore to see me, and I am glad we had a few moments to chat about your studies and your future. Your application for renewal of vows was processed today by the Provincial Council, and I am happy to admit you to a renewal of vows for one year. I will delegate Father John Mulligan (or whomever he names) to receive your vows at the end of your retreat with the Brothers of the New York Province.

I am sure you will spend the few hours you can spare for a retreat, in serious prayer and reflection, and so prepare yourself for a renewal of vows that will reflect a deepening of convictions and a growth in generosity. Be assured that your Brothers of the Pacific Province are with you, in thought, and in prayer. I regret that none of us can be there to share physically in your profession.

May God continue to bless you, Tom, and may you grow stronger in your Marianist vocation.

Sincerely,

Reverend Joseph Stefanelli, S. M.

C O P Y

April 8, 1974

Thomas E. Havel, M.D.
937-12th Street, Apt. 202
Santa Monica, CA 90402

Dear Dr. Havel,

Tom has just written me to tell me of your projected trip to Europe. I am writing to Father Tutas at our general headquarters in Rome to advise him of your arrival. Please get in touch with him; he will be happy to be of whatever assistance he can to make your stay enjoyable and profitable.

Our Rome address is Via Latina 22. The phone is 75 75 892.

My prayers and best wishes for your trip.

Sincerely,

Reverend Joseph Stefanelli, S. M.

MAR-ANL 000067

C O P Y

April 8, 1974

Reverend Thomas Havel, S.M.
3729 T Street, N.W.
Washington, D.C. 20007

Dear Tom,

Just a quick reply to your letter, as the Chapter gets under way. I have sent a note to your Dad about getting in touch with Father Tutas in Rome; however, your Dad may not get in before leaving. I will write to Father Tutas also, and ask him to call the hotel where your folks will be staying.

I am looking forward to seeing you in Baltimore. I hope it will not inconvenience your schedule too much.

Sincerely,

Father Joseph Stefanelli, S.M.

MAR-HAVL 000068

APR 8 ANS'D

April 3, 1974

| DATE | |
|------|--|
| | Dear Joe, |
| | <p>I thank you for your letter of the 15th. It will be good to see you when you get to Baltimore. Unfortunately, I will begin working at D.C. General Hospital on April 21st; so I don't have my schedule for that week-end yet. However I will call before I drive up to Baltimore.</p> |
| | <p>Right now I am doing my rotation on Internal Medicine. It is the busiest of all the services; so I don't have much free time. It is interesting but very demanding. It will be good to talk about something other than medicine.</p> |
| | <p>We do get 3 days off for Easter; and we do I plan on going up to Baltimore for Good Friday, Holy Saturday + Easter. Hopefully, I'll get away early on Holy Thursday.</p> |
| | <p>My parents are leaving for Europe next week. I know that it is rather late; but could you send my parents a letter of introduction to La Juntas. They will be in Rome April 17-24 at the Quirinale Hotel. (First they plan on spending Holy Week in Spain).</p> |
| | Have a Holy Easter, Tom |

MAR-HAVE 000069

C O P Y

December 6, 1973

Dr. Thomas E. Havel
937-12th Street, Apt. 202
Santa Monica, CA 90403

Dear Dr. Havel,

As you know, I was away for some meetings in Spain when your letter and check for \$2,000 arrived here. I want to take the occasion to express my personal gratitude to you for this, and for your many other manifestations of generosity in our regard. And I thank you also for your expression of best wishes for me in my functions as Provincial; I ask for a continued remembrance in your prayers.

The future contribution of the Province to the medical field seems to be solidifying itself. In addition to Tom, we have a young Brother preparing himself as a Physician's Assistant, another Brother presently working with the aged and infirm in a parish, a Brother working in a mission hospital in Africa, and a candidate who has had considerable experience in hospital administration. Perhaps Father Clemens' dream of a "medical team" will be realized. I am sure we can count on your advice when we get a little closer to the realizations.

My best wishes for you and the family, especially during this Christmas season.

Gratefully,

Reverend Joseph Stefanelli, S. M.
Provincial Superior

MAR-HAVL 000070

+

Dec 5, 1973

Dear Roger,

I certainly enjoyed our all too short visit in Baltimore. And it makes all the more meaningful for me to return to the Province and to Community Life. In fact I just purchased my ticket for my return in Jan.

~~Enclo~~ Enclosed is my expense report for November. I still haven't hear from Charlie Miller about the reason for his sending me the cheque for \$500.⁰⁰. Ask him if he will contact me as soon as possible. I don't like having an uncashed cheque sitting around.

Talked to my parents tonight. They are doing fine. But my father mentioned having made a donation to the S.M. about a month ago. As of today he hasn't heard whether or not the Province has received the cheque. Perhaps you could check it out for me.

Still don't know when I'll get my Christmas vacation. But it looks like the fuel shortage will keep me close to D. C.

Pray for me

In X t
Tom.

+

Nov. 11, 1973

Dear Roger,

I guess you won't see this until after you return to Spain. So I hope you had a good time and great things were accomplished at the meetings.

Things here are going along at the usual pace (constant). I finished General Surgery Rotation at the U. A. Hospital. Then I had 2 wks of Orthopedic Surgery & now I am back at Georgetown Hosp. for Neuro-Surgery.

About 2 wks ago I drove up to Baltimore & visited Joe Yax. He seems very happy & enjoys the work & the people in the rectory. I don't know when I'll get off for Thanksgiving but if I'm free, I drive up to Baltimore.

I really like PAC. It keeps me in ~~touch~~ touch with the Province & it gets parts of the P.A. to tell their works which we don't hear about ~~too~~ too often. But I would like it as Joe Priestly's newsletter to continue to give me some local community news.

Take care & keep me in your prayers until I see you all in Jan.

In Xt,
Tom

October 16, 1973

Reverend Thomas Havel, S.M.
3729 "T" Street, N.W.
Washington, D.C. 20007

Dear Tom,

Thanks for your letter of 29 September. I passed on your financial report to Brother Miller. I'm glad that you find the surgery rotation program interesting - you have to have an intense interest to keep up those hours. I know the hospital from my old C.U. days.

Glad to hear you get up to Baltimore. I know John Mulligan is always glad to see you. Do see Joe Yax - he always appreciates company from Pacific Province people. He is fearful of being forgotten or no longer accepted. Joe Davis will be interesting to talk with - I guess you know his position with the Black Catholic Movement. No pun intended but he has become a colorful if not controversial spokesman.

I also received a letter from Jack McNeil. Apparently he now resides at the University Catholic Center. I think this is much better for Jack although it sounds like he has been on the road rather frequently.

I mentioned hearing from you at our Provincial Council meeting last - so be assured of greetings from all on the Council.

MAR-HAVL 000073

C O P Y

Reverend Thomas Havel, S.M.
October 16, 1973
Page 2

It will be good to see you in January. Take care and
thanks for the letter. Good luck on your studies..
Keep us in your prayers. I hope your family is well.

Sincerely yours in J.M.J.,

Brother Roger D. Richter, S.M.

MAR-HAVL 000074

Sept 29, '73

Dear Roger,

Presently I am on the Surgery Rotation at the D. C. V. A. Hospital. It is the most interesting service I have been on so far; but the hours are long 6:45 am to 6:30 pm, 5 1/2 days a week, and on duty every 6th night. The hospital is owned by Catholic U. so it is a 20-30 min drive each way.

Weekend before last I went up to Baltimore. I stayed at the Provincial house. It was quiet & a good rest. Unfortunately I didn't see Joe Yarb. But I will definitely make it a point to see him next time up.

Joe Davis (from Cincinnati) called last night. He saw my name in the New York province Personnel. We plan on getting together some time next week.

Jack McNeil dropped me a note. I don't know how much the cause of Physics is being advanced; but it sounds like he is having a ball.

Unfortunately, the cut rate fares to L.A. are being dropped before I come home; I'm sure to make it there anyway. But, if it is still O.K. for me to go to the islands, I'll need some help for that leg of the journey (La. - to Ha). We'll talk about it when I see you in Jan.

Give my regards to the rest of the brothers at the Provincials. (Thank Joe for his letter. I'm looking forward to talking to him in Jan.)

Yours in Xt

Tom

C O P Y

September 7, 1973

Reverend Thomas Havel
3729 T Street, N. W.
Washington, D. C. 20007

Dear Tom,

Thank you for your letter of the 29th and your best wishes. I am gradually getting into the job; by now I hope you have received PAC 1 giving you some ideas of our plans. The Provincial Council met for three days at the end of August, and I think we are off to a good start.

I will be looking forward to seeing you in January when you have a vacation. My own plans will not bring me into your area until after Easter. I am certainly interested in your plans for the future, and I, too, hope we can move into some form of health-care apostolate. And I am in agreement with you that such work should be community-based. That is in keeping with what I consider a prime factor in Father Chaminade's thought: not only the aspect of community support and mutual compensation for personal limitations, but also the notion that it is the community itself that attracts and draws men to God. We will have much thinking and exploring to do when things get to the practical level, but I think we are looking in the right direction.

Be assured of my best wishes and prayers for you and your work; I am sure it is as difficult as it is interesting. Please keep me posted on your progress.

Sincerely,

Reverend Joseph Stefanelli, S. M.

MAR-HAVL 000076

SEP 7 ANSD

Aug. 29, 1973

Dear Joe,

A belated but sincere congratulations on your appointment as Provincial. It is a difficult job; but I know that you can count on the prayers, fidelity, and support of the whole province. To their's, I add my prayers and promise of fidelity and support in the years ahead.

Although I have not written for a while, I did have a good conversation with Roger when he was in D.C. I will not have a vacation until Jan 15th '74; but then I will give you a more detailed explanation of what I am doing and how I feel it will fit into the work of the Society. I feel strongly about an health-care apostolate. But I don't want to be a "loner." Any work I do has to be the work of the Society and done with other Marianists. As the time draws closer to the completion of my studies, I would like to know more about your thoughts on the possibilities for my future work in the Society.

Medical clerkships are very demanding. You are in the hospital any where from 10 - 36 hrs at a time. And you are still expected to fit in the required readings and study assignments. As of now, I have finished my Ob-Gyn rotation and about finished with Pediatrics. My next rotation will be Surgery.

As with everything else expenses are going up. Besides, this year my tuition grant was completely cut off. But with the B of A Loan and the donation to the Society from my Father, I think that I can cover the Junior year.

MAR-HAVL 000077

John Mulligan just called and invited me to join him and some other Marianists at their place in Cape May. Unfortunately, I planned on visiting a cousin at West Point. But I will probably go up there in late Sept. when the weather is more comfortable.

Enclosed is my expense sheet for the past 3 months. Please give it to Br. Charles with my apologies for being so late.

Please keep me in your prayers. And you and the work ahead will be in mine.

In Xt,

Tom

C O P Y

June 7, 1973

Reverend Thomas Havel, S.M.
3729 "T" Street
Washington, D. C. 20007

Dear Tom,

Thanks again for your steady stream of letters. It is always good to hear from you and find out the progress. I hope to see you very soon. I plan to be in Washington for a few days. I am scheduled to be there from the 30th of June through the 4th of July when I leave for New York. I am scheduled to stay at the Harrington Hotel in D. C. I never heard of the place but I suppose it is an okay hotel--American Express recommendation. It will be good to see you.

Two brief news items: John McCluskey is the new director of the Center community in Honolulu; Dick Britton of the Canoga Park Community. See you soon! Happy summer months.

Sincerely yours in J. M. J. .

Brother Roger D. Richter, S.M.

MAR-HAVL 000079

C O P Y

May 11, 1973

Reverend Thomas E. Havel, S. M.
3729 "T" Street
Washington, D. C. 20007

Dear Tom,

Although I did write to you last week about your renewal of vows, I did want to answer your letter of March 8 in which you had made your request for a renewal of your temporary vows.

As you already realize the Provincial Council has approved of your request for a renewal of temporary vows for one year. My sincerest congratulations to you, Tom. We are very happy that you are a Marianist and are very proud of you. We realize as you do that since you are living outside a Marianist community you do not have the daily contacts with the Marianists which are so helpful to our religious life. However, we know that you do have the strength and responsibility to live your Marianist commitment even while outside community. We are looking forward to the day when you will have completed your studies and are working back in the Province and living in one of our Marianist communities. I know that you also are looking forward to this time.

We are very proud of the success you are having in your studies. I do hope and pray that all continues to go well with you. You are daily in our prayers and we are continually asking our Blessed Mother and the Holy Spirit to give you a deep spiritual life and a close union with Christ. Do remember to keep us in your continual prayers also.

Congratulations again, Tom, on your renewal of temporary vows. God bless you!

Sincerely yours in J. M. J. ,

Very Rev. Bertrand E. Clemens, S. M.

MAR-HAUL 000080

C O P Y

May 4, 1973

Reverend Thomas Havel, S.M.
3729 "T" Street
Washington, D. C. 20007

Dear Tom,

Recently Brother Roger met with Father Mulligan to work on some papers they are to prepare for the next Provincials and Assistant Provincials' Meeting in St. Louis, Missouri. Father Mulligan mentioned that you made your annual retreat with some of the members of his Province, but did not renew your temporary vows at that time.

I have written to Father Mulligan in this same mail and told him that he could designate any priest to receive your vows. You may want to get in touch with Father Mulligan and find out whom he will delegate and when you could renew your vows. It might be well that you could renew them during Mass sometime after a day of recollection or when you are visiting one of the communities in the New York Province. Just work this out with Father Mulligan. I am enclosing the vow form for you, and you will need sign it and the date when you renew your temporary vows for one year. Also on this vow form should be the name of the priest who was delegated and did receive your vows. I believe this will take care of all that is necessary in this matter.

I hope all is going along well with you in your classes. By this time Brother Jack McNeil should be with you or have visited with you already. I am sure this will be good for both of you to be together for sometime.

I imagine Washington is very beautiful now with spring, and I hope you have a little time to enjoy all that nature offers after a long wet and cold winter.

MAR-HAVL 000081

C O P Y

Reverend Thomas Havel, S.M.

Page 2

May 4, 1973

Brother Ed Mulvaney is again in the hospital and will be there for at least six months. They are constantly taking out flesh from these sores on his hip, and the doctor hopes that none of the sores are so deep that they go into the colon. For awhile, Brother Ed was quite depressed. He is in better psychological condition now. He has really gone through much suffering.

The new infirmary here on the Provincialate property is coming along quite well. Now that the rains are over, the construction crew is working on the sight, and next week they will pour the final pillars. Once the pillars are finished then they can begin framing the house. I am sure much work will be accomplished this summer, since there are a number of Working Brothers who have volunteered to work on the infirmary.

Again, you are ever in our thoughts and prayers. I hope that all is going along very well with your studies, and that you are really enjoying them. Keep us in your prayers also. God bless you!

Sincerely yours in J. M. J. ,

Very Rev. Bertrand E. Clemens, S.M.

Enclosure

MAR-HAVL 000082

P.S. give Charlie the enclosed statement. Now that I have
the car + am moving, things will never be this good again!

May 4, 1973

Dear Roger,

WE had a very good retreat during Holy Week. It was held at Cardinal Gibbons High School in Baltimore. The retreat master, Fr. Campbell based it entirely on the Scriptures and esp. on the Scripture of Holy Week. Br. Howard Hughes did a great job with the liturgy and music. In fact the liturgies organized by John McGrath and Howard were what made the retreat so good. We also had a small prayer group which met every evening. Surprisingly it was the middle aged (and I include my self) that seemed to get the most from this type of prayer.

It was so good to be with people that didn't know the difference between a cathedral and a catheter (and what is more, they didn't care!!). It was good to be with real people.

John McGrath kidded me about the fact that I had finished my "official" retreat and yet had not renewed my vows. I told him that I guess that made me a free agent and I could sign on with any one now!!

Jack McNeil finally arrived last Tuesday. The trip was uneventful, except for the fact that he had to replace the tires and brakes in Oklahoma. He brought a very large trunk with him. In fact we had to take the deer off the car to get it out. He flew out Wed. evening, for Paris. And he is to be on the job on Monday (May 7th).

He told me that Fr. Clemens had resigned. It is probably best for him. (it is a difficult job for any man); but the province and I, especially, will miss him as my "boss". I think that he had the ability to bring out the best in all of us.

In. X6. Tom

MAR-HAVL 000083

C O P Y

April 17, 1973

Reverend Thomas Havel, S.M.
3729 "T" Street
Washington, D.C. 20007

Dear Tom,

Thanks very much for your recent letters. You certainly faithful in keeping me abreast of what is happening in Washington, D.C. and with regard to your work at Georgetown and the Medical School. I am glad that you had the opportunity to have a visit with Brother Bill Bolts. It must have been refreshing to have a break from all of your classwork at Georgetown.

I just returned from Korea and from Japan. I found things to be in a good state in Korea with the school doing well in Mokpo and with a lot of activity taking place in Seoul including the presence of quite a considerable number of potential Marianists among the native Koreans. On the way back I had a chance to talk to Brother Ray Mooney. He had applied to well over 13 schools offering physician assistants programs and it looks as though he may possibly be chosen for a position at Mercy College in Detroit, Michigan. He had been rejected by at least four of the schools because of lack of space and the large number of applicants. I will let you know more about this as things develop.

Tonight we begin our Provincial Chapter and then I go into New Orleans for the NCEA meetings. I suppose by this time Brother Jack McNeil has made it to Washington, D.C. Give him my best regards if he is still there. May I wish you a very Happy and Blessed Easter season. Hello from all here in Cupertino.

Sincerely yours in J.M.J.,

Brother Roger D. Richter, S.M.

MAR-HAVL 000084

MAY 1 1973

+

March 8, 1973

Very Reverend Bertrand E. Clemens, S.M.
Marianist Provincial Residence
P. O. Box 937
Cupertino, California 95014

Very Reverend Father;

This coming May third, I will celebrate the tenth anniversary of my ordination to the priesthood. I am grateful to God for His gift of perseverance. And it has been three and a half short years since I left the Diocese of Los Angeles and came to live the life of a Marianist. Thanks to the kindness and work of yourself, Fr. John Bolin and others, I had the privilege of making my first temporary vows as a Marianist last August.

After much thought, prayer and consultation with my confessor, I now request permission to renew these vows as a Marianist for one more year. Although I have not had the privilege of living community life for the last year and a half, I feel a greater need now more than ever to live the rest of my life as a religious of the Society of Mary. The kindness, concern and interest of my fellow Marianist are a constant source of God's strength and grace.

I look forward to the day when I am able to make my perpetual vows as a Marianist.

Faithfully yours in Christ,

Thomas E. Havel, S.M.

(Rev.) Thomas E. Havel, S.M.

MAR-HAVL 000085

March 7, 1973

Dear Roger,

First the bad news!! Yesterday the University announced a minimum \$1,500.00 cut in all grants, scholarships and loans. Hopefully the limit on Insured bank loans has been raised; but even with that increased source of money, things will be tight next year.

I will have car expenses for the first time. Also, I think that I will have to move from my present address to some other arrangement. Right now I am looking into the possibility of moving into the Jesuit Community at Georgetown. No matter where I move, it will be more expensive than my present room and board.

Now the good news! I got a card from Bill Boltz. He is going to visit me in D.C. during his spring break. Now, if we can ever get McNeil out of California, there will be a solid representation of members of the Province of the Pacific in the Washington area this spring.

I have not written to Ray Monney yet. Although I don't know what his plans are, I know that I will not be free to work in the Province in a Marianist Apostolate for at least five to ~~s~~ix years. But still it is not too early to try to establish some policy concerning the S.M. and the health care apostolate.

Enclosed are my letter for renewal of vows and the report for Br Charles. Please hand them on.

Yours in Ct,

Tom

MAR-HAVL 000086

C O P Y

February 15, 1973

Reverend Thomas Havel, S.M.
3729 "T" Street
Washington, D.C. 20007

Dear Tom,

I must acknowledge reception of both your note in January and the current one that just arrived the other day, dated February 6. I am glad that you are enthusiastic over this summer's priests' synod. I do hope that you will be able to participate in that particular meeting this summer if your studies will permit it.

I can imagine that you are very busy indeed with your work at Georgetown although certainly everything sounds as though it is going just great. We were all delighted that Jack McNeil finally had the opportunity to complete his doctoral studies at UCLA and will soon be on his way to Constance, Germany. We all pray for his success and that he will enjoy his stay there in Europe.

I don't see any difficulty with your planning on making the Holy Week retreat in Baltimore. Certainly I can understand the circumstances that might prevent your making a regular retreat in the Province during the summer. I have passed on the papers - the consultation for Assistant for Apostolic Action and the one for Brother Charles Miller.

MAR-HAVL 000087

C O P Y

Reverend Thomas Havel, S.M.

February 15, 1973

Page 2

Father Clemens is going through another illness which the doctors at this time aren't sure of. To them it seems to have some of the elements of rheumatic fever but the tests have not yet come back from the hospital to complete the diagnosis. Please keep him in your prayers.

I had an opportunity to spend some time with Brother Ray Mooney, the student Brother at Kieffer who is interested in paramedical training. He is very intent on preparing himself to be a physician's assistant and work with you after you have completed your medical studies and in practice. Let me know what your thinking is on this. I would appreciate whatever insight you might have and in the meantime you might possibly write to Ray Mooney in case he doesn't communicate with you. I have encouraged him to write to you so that you know what his thinking is.

Best regards to you, Tom, for everyone here at the Provincial House.

Sincerely yours in J.M.J.,

Brother Roger D. Richter, S.M.

MAR-HAVL 000088

February 12, 1973

Dr. and Mrs. Thomas E. Havel,
937-12th Street
Santa Monica, CA 90403

Dear Dr. and Mrs. Havel,

I wish to thank you sincerely for your check for \$2,000 given us as a gift for the Marianist Educational Fund. We appreciate very much this generous gift. As you mentioned in your letter, this gift will help us in solving problems that we are meeting.

I just wrote to Father Tom last week, for I had been visiting our community in Gardena, and the Brothers there had mentioned frequently how delighted they were with Father Tom when he was with them at Christmas time. The service and the understanding and friendship of Father Tom meant much to all the Brothers in Gardena. I wrote to Tom to thank him for this great concern for the Brothers.

I understand that this is a challenging semester for Tom in his studies. Next year most probably will not be as difficult as far as studies are concern, but I am sure that Father Tom will be busy with his work on the floors. We are very happy that Tom is with us and a member of the Society of Mary. We appreciate very much all that he means to us.

We hope that you are now in very good health again. We are concern about your health, and we keep you daily in our prayers and Mass.

Thank you again for your gift to us, and your continual remembrance of us. God bless you!

Sincerely yours in J. M. J. ,

Very Rev. Bertrand E. Clemens, S. M.
Provincial Superior

MAR-HAVL 000089

February 7, 1973

Reverend Thomas Havel, S.M.
3729 "T" Street
Washington, D.C. 20007

Dear Tom,

I have been thinking of you very much and wanting to write to you since I returned from Serra. Naturally, the Brothers were talking about you when I visited with them recently, because they appreciate very much having you with them during the Christmas holidays. Many thanks for being with the gang at Serra and taking such good care of them.

Also, I had some long talks with Jack McNeil, for when I arrived at Serra he was in bed with the London flu. I was delighted to learn that Jack has finished his doctorate studies and thesis and now can look forward in going to Constance, Germany. Naturally, he is relieved and all of us are very happy. I was overjoyed to learn that Jack will be driving your car back and have an opportunity to be with you in Washington before going over to Europe.

I understand that this is a real demanding year for you in your studies. I am sure you will be happy when this year is over and all the studies are behind you. I realize that next year the studies will not be as demanding, but your time will be taken up with your work on the hospital floor. I believe I remember, that you will be in Washington, D.C., all this next summer. I do hope you get a little chance for a break, and perhaps Jack McNeil can help you take such a break when he gets to Washington. We appreciate all you are doing, Tom, and certainly congratulate you on your progress that is outstanding and most successful. Thanks for everything.

MAR-HAVL 000090

Reverend Thomas Havel, S.M.

Page 2

February 7, 1973

Roger tells me that he hears from you and we appreciate that you write us so regularly. You are in our prayers. I hope that mother and dad are in good health.

Sincerely yours in J. M. J.,

Very Rev. Bertrand E. Clemens, S.M.

MAR-HAVL 000091

SAINT JOHN'S HOSPITAL

SISTERS OF CHARITY
1328 TWENTY SECOND STREET
SANTA MONICA, CALIFORNIA 90404

TELEPHONE 829-5511

FEB 12 ANS'D

February 6, 1973

Father Bertrand Clemens
Marianist Provincial Residence
Box 937
Cupertino, California

Dear Father Clemens:

Enclosed please find a check for \$2,000.00 as a donation to your Educational Fund.

I hope this will be of help to you in many of the problems that you have to solve during this year.

Respectfully yours,

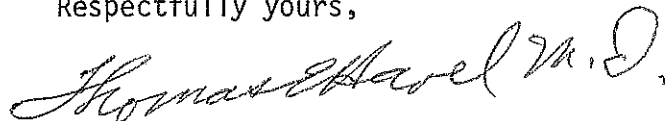

Thomas E. Havel, M.D.

Encl.

MAR-HAVL 000092



GEORGETOWN UNIVERSITY
SCHOOL OF MEDICINE
WASHINGTON, D. C.

Feb. 6, 1973

Dear Roger,

I had a pleasant surprise last Weekend. Rodney DeMartini came down from Baltimore and drove me back to visit Jorge daSilva and Bob Head at the Liturgical Workshop in Baltimore. It was good to see and talk to some "soul brothers" Rodney was very enthusiastic about the up coming liturgical workshop that he and John Mellon (sp?) will be running for the Province of the Pacific. The workshop here was very good, although I was a little surprised at the return of "liturgical postures" to the liturgy. It will be interesting to see the outcome of their efforts in our province.

All were very enthusiastic about the up coming "Priests' Synod". It was hopeful sign to share their positive and realistic expectations for the synod. I only hope that I will be free to attend.

Since I don't know when I will be free for vacation, I plan on making the Holy Week Retreat in Baltimore. But I am still expecting to make a retreat with our province, if at all possible.

Enclosed are some papers for other members of the P.A. Please see that they find their rightful slot.

In Xt
Tom

MAR-HAVL 000093

+

Jan 21, 1973

Dear Roger,

Please forgive the delay in writing this month. But I have been preparing for finals.

It was good to go "home" to Serra for the Holidays. I had a great time there as usual. But I did get the flu the last few days of vacation which delayed my departure for three days.

Br. Charles probably informed you that I purchased a car which Jack McNeil, in his kindness, will drive to D.C. for me. I suspect that it will well tested by the cold weather of Alta and Vail before I see them both!!

We finished the last test of the semester last Thursday. And I am sure that I passed them. So now after a three day intersemester holiday, we begin the new semester tomorrow. I will be taking Microbiology, Community Medicine, Introduction to Clinical Science, and 4 electives. (I haven't received the assignment of electives yet.)

I finally received my physical exam, so now on the next pay period I expect to finally get paid for my work on the blood drawing team.

What with the car and not having classes on Saturday, I hope to get up to Baltimore more often.

Please give Br. Charles the enclosed paper.

*In Xt,
Tom*

MAR-HAVL 000094

December 9, 1972

Reverend Thomas Havel, S.M.
3729 "T" Street
Washington, D. C. 20007

Dear Tom,

Thanks for your letter of November 7. I passed on the account to Brother Miller. That \$200 necktie really sounds great. Everything is climbing in prices but I almost think the average monk never realizes it!

I am at Canoga Park on visitation right now and had a chance to get over to Gardena on last Sunday. They were on retreat so I got to see all of the community. All look well--even Joe Kindel is sporting a little fuzz under his nose these days! I talked with Jack McNeil. He is putting on weight which I think is primarily due to nerves. He really wants to get finished but his major professor seems to be in a little hurry to wind up the show. He went away for a month but was forced to return when he got a case of the gout. Jack feels this is God taking revenge on the man. All in all he still hopes to be in Germany very soon--within a month or so. Keep him in your prayers.

Glad to hear that all goes well with you and your studies even though they do keep you busy. If you get a chance during the holidays--do drop by Cupertino and say hello. I hope you have a nice Christmas vacation in the southland.

Sincerely yours in J. M. J. ,

Brother Roger D. Richter, S.M.

MAR-HAVL 000095

DEC 9 ANS'D

Nov. 7, 1972

Dear Roger,

Nothing much happening here in D.C.
Except for the fact that it has been a
beautiful fall.

They are keeping the pressure on in
school. We have a test every Monday
from now until Christmas vacation.

I did receive a money gift from my parents
for my birthday. So I bought a \$200.00
tie. I all started with another gift I
received - a dress shirt. I needed a tie
to go with it. But then the tie need a
matching pair of slacks. The slacks needed
a belt. The belt needed shoes to go along
with it. And the whole thing needed a top
coat to cover it and me for the winter.
But the top coat had both blue and tan
checks in it; so I needed another outfit
to go with the tan checks too!
Actually, I ~~will~~ need the shirts and ties
already on the days I do histories and
physicals on patients.

I hadn't bought any clothes for about four
years. And I couln't believe the prices!

I hear that McNeil is still in California!
If you see him, tell him that I'll probably
get my doctorate before he does.

MAR-HAYL 000096

I received a letter from Jim Orsini. Just before he returned to the recruitment workshop. I was sorry to hear about his auto accident.

Tell Joe Priestly that I like his newsletter very much. In fact, every bit of information from the province is greatly appreciated and read. (In fact, I read more of them now than when I was in Community!)

I don't think that I will get up to Baltimore before I return to L.A. Thanksgiving I will spend in D.C. I have a cousin here who is having me over for Thanksgiving. And the rest of the vacation will be spent on preparing for a Pharm. Test.

Please give Br. Charles the enclosed expense account.

Keep me in your prayers. And be assured that you all are in mine.

In Xt,

Tom

October 25, 1972

Reverend Thomas Havel, S. M.
3729 "T" Street
Washington, D. C. 20007

Dear Tom,

Thanks very much for your letter of 3 October which was on my desk when I returned from NCEA Superintendents meetings in Omaha. I know that the check that you enclosed with your letter has been taken care of. You are carrying quite a load with 27 hours of class a week. But I know that you have high hopes, motivation and interest so I guess it makes it that much easier.

I gave Brother Charles Miller the expense account for September. I do hope that you have an opportunity of flying home this Christmas and visit with your family and the Brothers here in the homeland. I guess you have already received notification that both Brothers Leo Mulry and Richard Carter passed away in Honolulu within about a week of each other. Brother Leo, as you know, suffered from cancer and Brother Richard Carter died as a result of a heart condition.

Everyone here at the Provincial House sends you their best regards. By the way I did hear that Jack McNeil expects to complete his work at UCLA within the next two or three weeks and be on his way at last to Germany. I hope you have a white winter in Washington, D. C.

Sincerely yours in J. M. J. ,

Brother Roger D. Richter, S. M.

MAR-HAVL 000098

10/3/'72

OCT 25 ANS'D

Dear Roger,

Things here are at a busy pace. I have classes on five and half days. But fortunately my class on saturday is very interesting. It is my Physical Diagnosis class which includes doing histories and physicals on patients in the hospital.

My other courses include Pathology, Pharmacology, Introduction to Clinical Science, Selfinstruction in Ophthamology, Normal Radiographic Anatomy, and Ethics. All in all, it is about 27 hours of class a week.

Fr. John Mulligan had Silver Jubilee Celebration about 10 days ago; but, unfortunately, I had a test the next day and so was unable to attend.

Enclosed you will find a cheque given to me for some work I did over the summer. But they made it out to the Society of Mary. Could you give it to Br. Charles and ask him to return a cheque made out to me. (Fr. Clemens has given me permission to use any gifts that I receive.)

Also please give Br. Charles the enclosed Expense Account for Sept.

There is a possibility of flying home this Christmas. But the details are not certain yet.

Take care and God bless.

In Xt,

Tom

MAR-HAVL 000099

September 11, 1972

Reverend Thomas Havel
3729 T. Street
Washington, D. C. 20007

Dear Tom,

My belated congratulations upon your profession of vows in the Society of Mary. It is very good to have you with us through profession of vows. I hope that your dad is feeling better these days and that his recovery will be complete.

I had the occasion to spend a few days with Father Mulligan and he always wants to assure me that you are always welcome to the Provinciate in Baltimore or to the Gibbons community whenever you can make it to Baltimore.

Thanks for the report on what this semester holds for you at Georgetown. It sounds like quite a challenging lineup of courses. Good luck! The change in scholarship is not too great. I am sure you will keep Brother Charles informed of the necessary changes he should make in his budget figures. I hope to be seeing you sometime during the year. Please be assured of our continued remembrance of you in our prayers and thoughts.

Sincerely yours in J. M. J. ,

Brother Roger Richter, S. M.

MAR-HAVL 000100

+

9-1-72

SEP 11 ANS'D

Dear Roger,

I arrived safely last Tuesday.
Classes began today with a full schedule.
I'll probably go up to Baltimore this weekend
and see John Bolin.

My financial aid from the school dropped
from \$2800.- to 2400.00 per year. So I
now have a \$200.- bill for tuition each
semester.

The weather here has been good but I'm
sure that it won't last long.

My courses for this semester include:
Pathology, Pharmacology, Physical Diagnosis,
Introduction to Clinical Science and two
electives (yet to be selected)
So you can see that it will not be a dull
year.

I'm sorry that the note is not more informative
but I write more later

In X t

Tom

P.S. Please give Dr. Charles the enclosed
form.

MAR-HAVL 000101

March 17, 1972

Reverend Thomas Havel
3729 T Street
Washington, D. C. 20007

Dear Tom,

In the Provincial Council meeting of March 13, 1972, we considered your request to take temporary vows in the Society of Mary. The Council unanimously approved your request. My sincerest congratulations to you, Tom!

I am sure that you will be very happy to receive this good news about your acceptance into the Society of Mary. Also, I assure you that we are very happy and privileged to have you become a member of the Society of Mary. I am sure that your studies are coming along well, and that fact along with the acceptance now into the Society is enabling you to attain the goal that you have set for yourself as a Marianist priest in medicine.

If it is still agreeable with you, we shall plan that you would take your first vows at the close of the annual retreat in Danville. That retreat extends from August 8 to the 13th. I would encourage you very much, Tom, as you look ahead now to your profession of vows that you continue to read and study, even if for brief periods, some of the writings of the Society of Mary. I am sure that such reading and study will enable you to even grow more deeply in your understanding and love of the Society of Mary.

I am looking forward to seeing you when Brother Roger and I are in Baltimore for the Provincials and Assistant Provincials' meeting. We shall be at the Provincialate in Baltimore of the New York Province from Friday, April 7 till Sunday, April 9 included. I do hope you will be able to get away from Washington long enough to visit with us in Baltimore.

MAR-HAUL 000102

Reverend Thomas Havel

Page 2

March 17, 1972

Again, my sincerest congratulations to you, Tom, upon your acceptance into the Society of Mary. You are loved and admired by all the Marianists, we are privileged to have you join the Society of Mary. You are ever in my prayers. May God continue to bless you and your studies.

Sincerely yours in J. M. J. ,

Very Rev. Bertrand E. Clemens, S.M.
Provincial Superior

MAR-HAVL 000103

*now
given
Council meeting
March 13, 1972
P.*



MAR 17 1972

GEORGETOWN UNIVERSITY
SCHOOL OF MEDICINE
WASHINGTON, D. C.

March 3, 1972

Very Reverend Bertrand E. Clemens, S.M.
Marianist Provincial Residence
Province of the Pacific
P.O. Box 937
Cumpertine, California 95014

Very Reverend Father:

With this letter I would like to formally make the following requests. First, I wish to be officially received into the Society of Mary. And second, I wish to make temporary vows of poverty and obedience, as well as renew my vow of chastity, as a member of the Society of Mary.

After having spoken to you during the Christmas Holidays and to my confessor here, it is my desire to join the Marianists. I do this of my own free will with no outside pressure or influence.

My two years of living in Marianists Communities and even the few months living outside of community have convinced me that I wish to follow the Laws and Counsels of Christ as a member of the Marianists. It is not only the rule but also the spirit which Father Chaminade gave the Society that draws me to the Marianists. And I whole heartedly wish to make the Society, its rule of life, its spirit, and its apostolic goals the center of my life and my way to Christ.

MAR-HAVL 000104

I pray always that as a Son of Mary, she will help me to live the life of a good Marianist.

In Christ,

Thomas E. Havel

(Rev.) Thomas E. Havel

November 3, 1971

Reverend Thomas Havel
3729-T Street, N. W.
Washington, D. C. 20007

Dear Tom,

Many thanks for your letter of October 26. I assure you it is always good to hear from you. I am happy that all is going well with you, but I certainly understand that you are very busy, and that your courses are keeping you extremely preoccupied. I am happy that all is going along so well with you.

I was sorry to hear that Dad is not too well. I certainly agree with you that it would be wise for you to visit him at Christmas. It is also very thoughtful of friends to invite you to their homes for Thanksgiving. It is also good to realize that the communities in the New York Province are so hospitable. I am grateful for this.

I am sure you will hear from Father Bolin, but he has been very busy of late. He was away from the Islands to attend the Seminary Board meeting and to have formation meetings over here. Now I know he will be busy catching up on classes with the novices, but I am sure he will write to you. We will certainly keep you on the mailing list, so you will be receiving all the materials going out from here. If you get a chance when you come to California for Christmas to come up this way, do not hesitate. It will be great seeing you and speaking with you. Do write when you get a chance and let us know how all is going along with you. We know you are busy, yet we are always happy to hear from you. You are in our prayers.

Sincerely yours in J. M. J. ,

Very Rev. Bertrand E. Clemens, S. M.

MAR-HAVL 000106

NOV 3 AMST

October 26, 1971

Dear Father,

Things here are coming fast and heavy. I just finished a Gross Anatomy Exam on the Head and Neck. It took all day - morning being a written part and afternoon being a practicum.

Made a trip to Baltimore last week (Oct 16-17). As usual they treated me very kindly. They invited me to a Retreat on the General Chapter Documents for the weekend of Nov. 20-21. Unfortunately, I have a Neural Anatomy Exam on the following Monday, so I will not be able to go. But I do hope you will forward me a copy of the Documents when they become available.

Some friends (from Caltech) have invited me to Yale for the Thanks giving Weekend. And I would like to go up there if possible.

Also things at home healthwise are not too good. My father has begun to take nitroglycerine tables on a rather regular basis. Which I think is a sign that his heart condition is not getting better. Consequently, I would like to fly home for Christmas. I have enough money in my account to see me through the school year and still buy the tickets.

I wrote to John Bolin; but I haven't heard from him yet. I know he is busy (just read the news letter) so I don't expect too much correspondence.

That's about all from here. Keep me in your prayers and I will do the same.

In Xt,

Tom

MAR-HAVL 000107

5-17-71
BC

October 14, 1971

Father Thomas E. Havel, Jr.
3729 T Street NW
Washington, DC 20007

Dear Tom,

I am sending on to you a couple of enclosures that I think will be of interest.

The first is a copy of a letter from Father Ted Cassidy, director of our community in Chester, Pennsylvania. He is inviting all of us Marianists to a Halloween celebration at their community. As you will note from the letter, we hope that Father Tutas, our new superior general, will also be there for the occasion. You may have received such a letter directly from Father Ted, but I am sending on this one just to make sure that you know that you are included in this invitation. It would be good to let him know if you plan to attend.

I am also sending on a copy of the most recent issue of the MARIANIST RESOURCES documents. Along with it is a form requesting to be placed on the mailing list. In case you have not already received this same issue, I suggest that you return the request form to St. Louis so that you will be sure to receive subsequent copies.

Your name has been added to our mailing list for provincial bulletins, etc., and I hope that these have already been coming your way. Specifically, the workshop for our priests is coming up in November and we would certainly be delighted to have you join us on this occasion.

One of these days I hope to stop in on you in Washington, but don't hold your breath. In any case, you are always welcome here. I heard recently that you had been over to Cardinal Gibbons again and that is good to know.

Fraternally yours,

Very Rev. John D. Mulligan, SM
Provincial Superior

Enclosures

MAR-HAVL 000108

SERVICES INCLUDE:

- Individual Therapy
- Group Therapy
- Alcohol/Drug Counseling
- Marriage Counseling
- Pre-marital Evaluation
- Psychological Testing
- Spiritual Workshops
- Professional Workshops
- Retreat Weekends
- Consultation to parishes and religious communities

**CARING FOR
THE WHOLE PERSON**

Living and working in a highly complex contemporary society creates emotional stress for church ministers as well as the persons they serve. Periodic mental health care has become an accepted part of everyday life in our present society.

Catholic spirituality ... and solid medical and psychiatric principles form the foundation of the Pastoral Services Center. Unique in its ability to treat the whole person, the center recognizes the role of God, both in the healing process and in the therapeutic experience.

The Pastoral Services Center at St. Joseph's College in Mountain View is a non-profit mental health clinic with a staff of experienced Catholic doctors, both religious and lay. The center specializes in counseling priests, religious men and women, and lay persons ministering in the church. Others are seen on request.

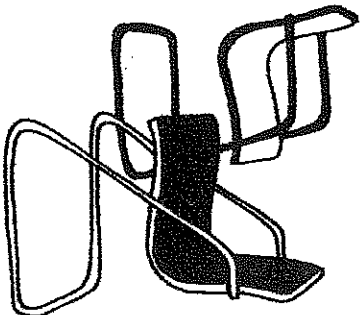

For information call:
(415) 968-0689
All inquiries confidential

Non-Profit Organization
U.S. Postage
PAID
Los Altos, CA
Permit No.

5932

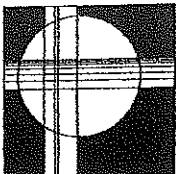

Pastoral Services Center
101 First Street #400
Los Altos, CA 94022

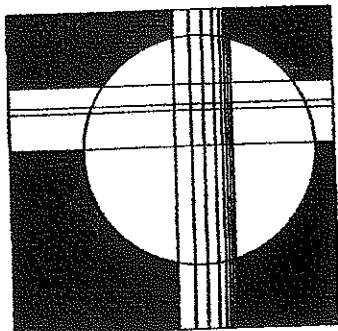

**PASTORAL
SERVICES
CENTER**

A comprehensive
Catholic mental health facility

MAR-HAVL 000109

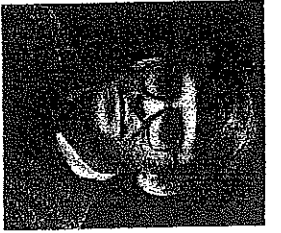

V. JAMES S. TUCKER, S.S., Ph.D.

Profession: Subjoiden priest, clinical psychologist, marriage/family counselor, primary instructor

Experience: Staff, McAuley Neuropsychiatric Unit; psychological testing, therapy for clergy, religious, married couples

Specialties: Stress disorders, depressive conditions, psychosexual disorders

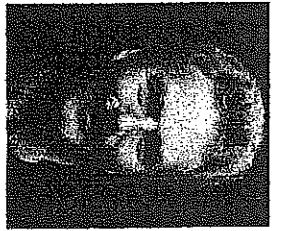

GERALD B. DOOHER, Ph.D.

Profession: Alcoholism/drug counselor, medical researcher, seminary instructor

Experience: Faculty appointments at Cornell University Medical College and Sloan-Kettering Institute; training of medical students and clinical psychologists

Specialties: Clergy, religious, and lay persons with chemical abuse problems and eating disorders; families and friends of alcoholic drug abusers; pastoral counseling

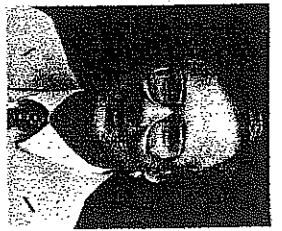

LAWRENCE P. PERCELL, Ph.D.

Profession: Clinical psychologist, seminary instructor

Experience: Psychotherapy with adults and couples; psychological assessment and consultation

Specialties: Anxiety and depressive conditions, interpersonal conflict resolution



REV. THOMAS HAVEL, S.M., M.D.

Profession: Morianist priest, physician, psychiatrist

Experience: Medical director of psychiatric unit at El Camino Hospital; clinical instructor at Stanford University School of Medicine; consultant to religious psychotherapists; private practice in adult psychiatry

Specialties: General adult psychiatry, psychological psychiatry, especially affective disorders; short and long term psychotherapy

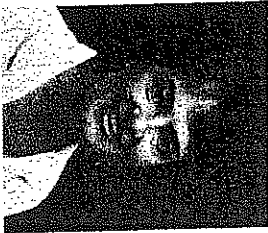

IAN A. BITTER, R.N., Ph.D. (cand.)

Profession: Psychological assistant in clinical psychology

Experience: Marriage counseling, psychological testing, stress reduction, crisis intervention, mother of nine children

Specialties: Bioenergetics, Jungian psychotherapy, life transitions

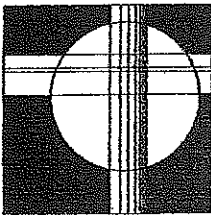

MICHAEL C. NERI, M.A., Ph.D.

Profession: Pastoral counselor, marriage/family counselor, seminary professor

Experience: Teaching, training, and counseling clergy, religious, and lay ministers; education and counseling to individuals, couples, and families

Specialties: Personal growth, relationships

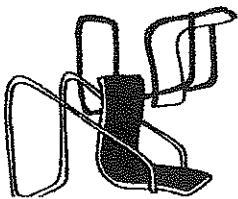

September 27, 1971

Reverend Thomas Havel
3729-T Street, N. W.
Washington, D. C. 20007

Dear Tom,

Many thanks for your letter of September 18. Brother Roger received your correct address and this is now in the new personnel, which you certainly have received by this time.

I am happy that you have found a suitable place to live. I do hope that all works out well in this new residence.

You certainly have a very heavy schedule. I am sure you will do well, but do not worry about your studies. You will continue to work as you have while at Loyola, and I know you will succeed. Have no concern. We will certainly keep you on our mailing list, and we will keep in touch with you. Do keep in touch with us, for we are always anxious to hear from you.

Brother Roger and I will be going to Serra and to Canoga for talks on the General Chapter. You probably have heard that Brother Ed Carey is in the hospital and recuperating from an operation. A part of his intestines was removed because of some scar tissue that was causing an obstruction. He seems to be doing quite well and is recuperating as quickly as can be expected.

Be assured that you are in our continual prayers and thoughts. Keep us in yours, and write when you get a chance. It is always good to hear from you.

Sincerely yours in J=M. J. ,

Very Rev. Bertrand E. Clemens, S.M.

MAR-HAVL 000111

C
O
P
Y

SEP 27 ANSU

Marianist Community

CARDINAL GIBBONS HIGH SCHOOL
1001 S. CATON AVENUE
BALTIMORE, MARYLAND 21229

301-644-1770

September 18, 1971

Very Reverend Bertrand Clemens, S.M.
Marianist Provincialate
P.O. Box 937
Cupertino, California 95014

Dear Father;

I received the "Non-parochial Faculties" of the Archdiocese of Washington yesterday. Thank you very much for writing to them.

I hope you didn't mind my calling the Provincialate collect last week. But the experience of that first rental was so bad that I didn't want any correspondence mailed there. I don't even want to see the place again if I can help it.

My new address is: Rev. Thomas E. Havel
3729 - T Street, N.W.
Washington, D.C. 20007

My telephone number is 202-333-3167

Mrs. McCauley, my new land lady, is very kind. She has offered me board. All I have to pay is one third of the shopping costs which is about ten dollars per week. The other lady who lives here is also very nice. Her name is Miss Flaharty (Dutch). She used to be a housekeeper in a rectory; so we exchange many interesting stories about parish life.

I just received your letter of September 13th. I will write to John immediately.

My class schedule is very heavy (about thirty hours a week). And my classes include: Gross Anatomy, Embryology, Cell Biology (mostly biochemistry) and Gross Anatomy lab. The work has been coming fast and furious. I had to spend eight extra hours in the Anatomy Lab (above and beyond the scheduled nine hours) just to keep up with the material.

I have two electives in addition. One is Environmental Ethics every other Tuesday evening for two hours. The other is Developmental Immunology. The latter is a

MAR-HAVL 000112

Marianist Community

CARDINAL GIBBONS HIGH SCHOOL
1001 S. CATON AVENUE
BALTIMORE, MARYLAND 21229

301-644-1770

by far the most interesting class. It is taught by a Dr. Bellanti, who has a text book coming out in this field soon. It is three hours long. And is held on Thursday afternoons. The first half alternates between a lecture one week and a student presentation the next. I have a presentation coming up on October twenty first on "Immunological Compliment" and "Uses and Abuses of Gamma Globlin". I know so little about this field that it will require a lot of back ground reading before I do the actual presentation. The last half of each class is spent in the hospital observing clinical presentations about the subjects covered in the lectures and presentations. So I start wearing my "white coat" next week. I may look like a doctor; but I sure don't feel like one yet.

I have decided to wear my clerical shirt to classes. I believe that it is good for me and for those whom I meet. I don't plan on upstaging the faculty and chaplain; but already I have been in some very interesting discussions. I haven't decided whether or not I will wear it in the hospital. I'll probably discuss that with Dr. Bellanti and follow his wishes.

It hasn't been all study. Yesterday, I had a "beer with the boys" after classes. Boy do I hate beer! But it is a part of the academic life I haven't experienced up to now so I'll probably be doing it again from time to time.

Because my Environmental Ethics class is every other Tuesday evening; I have Friday afternoon free. This gives me a longer weekend and I hope to get to Baltimore more often.

The cheque for my student loan came yesterday. Since I won't need the money until next semester, I will probably put it into a savings account. But, if it would be more acceptable to forward it to Br. Charles for his use, let me know.

I have also agreed to help the chaplain at the Medical School by offering Mass at noon in the chapel on a regular basis.

That's about all from here. You and the whole province are in my thoughts and prayers often.

In Xt,

Tom.

MAR-HAVL 000113

September 13, 1971

Reverend Thomas E. Havel, S. M.
3729 T Street, NW
Washington D. C. 20007

Dear Tom,

Many thanks for your long letter of September 15 concerning your trip back to Washington D. C. and concerning your first impressions of Washington. I was very happy to read your letter and to hear that, despite difficulties, you arrived safely in Washington. Your experiences as you traveled across country must have been most interesting.

I am happy that you have finally found a suitable home near to the university. Brother Roger informed me that you called and gave us your new address. Many thanks. Father Mulligan, the Provincial of the New York Province, has asked for some information concerning you, so that he could publish it in a future newsletter to his province, so that the Brothers in the New York Province would be acquainted with you before they even meet you. I am very happy that you have found a warm welcome in the communities in the New York Province. I am sure you will experience this everywhere.

After you have gotten settled in your classes, do let us know how all goes with you in your studies. I do think it would be well if you kept in contact through letters with Father Bolin, so that he could direct you even at a distance concerning your program of study and reading regarding Marianist doctrine and heritage. As soon as we have received in print the declarations of the recent General Chapter, we shall make sure that you receive a copy. I am sure you will find the declarations very inspiring and helpful to your life style as a Marianist.

I am sending to you a thermofax copy of a letter I received from the Chancellor of the Archdiocese of Washington. By this time, I am sure you have received your faculties for the Archdiocese. If you have any difficulty in this regard, do not hesitate to write me.

MAK-HAVL 000114

Reverend Thomas E. Havel, S.M.

Page 2

September 13, 1971

Be assured that you are in our thoughts and prayers. Brother Roger and I will be in Baltimore for the annual meeting of the Provincials and Assistant Provincials of North America after Easter. We certainly will be in touch with you while back there. You might want to keep this in mind as you plan your timetable for the year.

You are in our thoughts and prayers. Be assured that you, your life as a Marianist, and your successes in the study of school be everyday present in our petitions at Mass. God bless you.

Sincerely yours in J. M. J. ,

Reverend Bertrand E. Clemens, S.M.

Enclosure

MAR-HAUL 000115

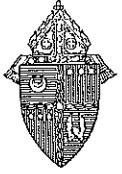

ARCHDIOCESE OF WASHINGTON
CHANCERY OFFICE
1721 RHODE ISLAND AVE., N. W.
WASHINGTON, D. C. 20036

September 7, 1971

Very Reverend Bertrand E. Clemens, S.M.
Provincial Superior
Marianist Provincial Residence
P. O. Box 937
Cupertino, California 95014

Dear Father Clemens:

In response to your letter of August 26th, I have forwarded directly to Father Thomas Havel the non-parochial faculties of the Archdiocese.

With every good wish, I am

Sincerely in Our Lord,

Most Reverend Edward J. Herrmann, D.D.
Vicar General - Chancellor

EJH/eq

MAR-HAVL 000116

~~SEP 2~~ ANSD

Marianist Community

CARDINAL GIBBONS HIGH SCHOOL
1001 S. CATON AVENUE
BALTIMORE, MARYLAND 21229

SEP 13 ANSD

J.M.M.

301-644-1770

Sunday
September 5, 1971

Very Reverend Bertrand Clemens, S.M.
Provincial of the Province of the Pacific
Marianist Provincialate
P.O. Box 937
Cupertino, California 95014

Dear Father,

First Report of the Washington, D.C. Community of the Province of the Pacific.

I love it!!! With all due respect to those who come from San Francisco, I think that Washington, D.C. is the most beautiful city in the world. It is almost (I said almost) as grand as the High Sierra Mountains. And the people, the city and the campus of Georgetown are all great. I only hope I'll feel this way after classes begin. But let me begin at the beginning.

I promised to drive a VW of a friend of mine back to Washington for her. It was a 1965 V W with 90,000 miles on it. And looking back on it now, it was stupid of me to agree to drive it across country 3000 miles. But I did. So, Saturday, August 29th, after officiating at a wedding of an old high school classmate, I started out. It was about 5:30 pm. About 150 miles out of L.A. in Victorville, the car threw a rod. It was after 7:00 pm and no place was open. So I had the car towed to the V.W Agency and left it there until Monday. There was a county fair going on in Victorville, so I was unable to get a room. Fortunately, Frank Spath and Leonard Chang came out in a van from Chaminade and picked me up. They brought me and my baggage back to Canoga Park. In repacking the van with my baggage, a can of gas leaked all over two of my boxes of clothing; so I spent Sunday washing and repacking.

Jack McNeil came early Monday morning and drove me back to Victorville. They had to put in a rebuilt engine for about \$400.00. Fortunately, the family of the girl who owned it agreed to pay me back when I arrived in Washington. So at 5:00 pm Monday, August 31st, I started out again.

Just as I entered the on ramp in Victorville. I picked up a hippie type hitch-hiker. (This turned out to be a God send) I was packed to the gills and I wouldn't have picked him up except for the fact that he had only a small pack. I thought that he would only be going a short way; but it turned out that he was going to Philadelphia!

MAR-HAVL 000117

Marianist Community

CARDINAL GIBBONS HIGH SCHOOL
1001 S. CATON AVENUE
BALTIMORE, MARYLAND 21229

2

301-644-1770

Phil (we never got beyond first names) shared in the driving; so I was able to drive straight through. This helped make up for the time lost in Victorville.

In Albuquerque N.M. I was supposed to have a 600 mile oil change and valve adjustment. But the V.W. Agency was so busy that I would have to have waited for seven hours. But Phil came through. His little pack was full of tools. He changed the oil and adjusted the valves on a side road just outside Albuquerque. And so we were on our way in less than an hour!!!

Later on that day (Tues.) the fuel pump became blocked in Vega, Texas. Again Phil came through. He took it all apart and cleaned it out. And again we were on our way in less than an hour.

Phil was a vegetarian and besides that, he didn't believe in spending money in establishment-type places like restaurants or name brand gas stations. So we bought the cheapest gas and stopped in grocery stores for our food (a loaf of bread and a quarter pound of Cheese). No one has gone across this land more cheaply! He has absolutely no money. But even with me paying for everything, it cost me less than \$80.00 (including gas, tolls, and food).

Since Phil had been so helpful, I drove him to Philadelphia. We arrived in Philadelphia about midnight Wednesday. 55 hours on the road!!! I took a shower in a pad of a friend of his, which was above a boarded up store in the slum area of Philadelphia. And I also eat there (vegetarian of course).

Without Phil, it took me three hours to drive to Baltimore; but I arrived at Gibbons about 4:00 am. Later on in the morning I drove on to Washington to deliver the car. The family (Goldblat by name) live in Georgetown and want me to stay with them. But it took a hour of walking and using public transportation to get to Georgetown; so I determined to find a place within walking distance of the Medical School.

Next day (Friday) I met the chaplain of the Medical School (Fr. Leo Monihan, S.J.) who took me to dinner with two scholastics who are Sophomores in the Medical School. Although they couldn't offer me a place to stay, they did make me feel welcome and invited me to visit any time the two small satellite communities where they live (and are within walking distance of Georgetown Campus).
both

MAR-HAVL 000118

Marianist Community

CARDINAL GIBBONS HIGH SCHOOL
1001 S. CATON AVENUE
BALTIMORE, MARYLAND 21229

301-644-1770

Friday, I also looked for a room near the University. Since I arrived a little late, most of the rooms were taken and those that were left are very expensive. I did find a room within six blocks of the Medical School. It is right in the heart of old Georgetown and the home must be at least 150 years old. I got a room and a 1/2 bath on the first floor for \$125.00 per month! I have to go to the third floor to take a shower. I know that this is very expensive,; but the advantages of easy walking to the school and to the Jesuit communities make it worth while.

After seeing Washington traffic and drivers, I will never own a car here. You take your life into your own hands every time you get behind a wheel. And even though the public transportation is good, it takes too long. Besides ~~Last~~ Friday while I was returning from dinner with the Jesuits, there was a mugging going on at the bus stop just before the one where I had to get off for a transfer!

Saturday, I tried to find a bank, but none would accept the cashier's cheque that I had. It would take up to two weeks to verify it. So Tuesday I plan on going to the University for help.

Tell John Bolin not to worry about his novice in Washington. My landlady (a cultured Virginian) is acting like a Mistress of Novices. No long haired left wingers are allowed in. All doors must be kept open when the room is not occupied. No drinking or smoking in the rooms. No tv or radio can be played loud enough to be heard outside your room. And the roomers must bathe at least every other day (she cannot stand body odors)!!!!

Saturday, I also took the Greyhound Bus to Baltimore. Everyone has to experience the Greyhound Bus Depot in Washington D.C. It is the most crowded spot in the world - an argument in itself for Birth Control. And no one is really sure that he has acquired the virtue of patience until it has been tested by standing in line for a bus that never seems to arrive.

Saturday and Sunday I am spending at Gibbons High School. The brothers' house is equal parts Holiday INN and Bastille. But the brothers here have been wonderful to me and have made me feel at home. Last night (Sat.) I went to the Hilton Community where five Marianists and two aspirants live. And today I went to a supper at Westview, a satellite community of five teaching brothers from Gibbons. There I met the Provincial of the New York Province and was invited to visit their house on the next visit.

Tomorrow I return to Washington to move into my new room. Wednesday, Thursday and Friday are orientation days. Ann
Monday Sept. 13th I begin school in earnest.

MAR-HAVL 000119

Marianist Community

CARDINAL GIBBONS HIGH SCHOOL
1001 S. CATON AVENUE
BALTIMORE, MARYLAND 21229

301-644-1770

My new address will be:

Fr. Thomas E. Havel
1530 - 34th St. N.W.
Washington, D.C. 20005

202- Federal 8-3251
Use the phone only in emergencies!

As you can see, it hasn't been dull.

Keep me in your thoughts and prayers.

In Christ

Tom

Thomas E. Havel

P.S. Don't forget to send the letter for me to get faculties.

P.P.S. I almost forgot. There is an Adult Family of Mary Group
in Washington. I plan on contacting them next week.

MAR-HAVL 000120

chaminade
preparatory

August 24, 1971

Very Reverend Bertrand Clemens, S.M.
Provincial of the Province of the Pacific
Marianist Provincial Residence
P.O. Box 937
Cupertino, California 95014

Dear Father:

Yesterday a unexpected but wonderful letter came in the mail. Georgetown University gave me a Tuition Grant of two thousand eighthundred dollars (\$2,000.00)!!!!!! The letter went on to say that the grant would be renewable each year if I would apply. This amount is for the full tuition; so that part of my expenses has been removed.

Also, in my last letter I forgot to ask for a "celebret" or a letter from you which will allow me to apply for faculties in the Archdiocese of Washington.

You had better send all correspondence to Gibbons High School, Baltimore, Md.; until I mail you my permanent address.

I am convinced that Christ has blessed me beyond anything I may deserve. And my whole life spent in service in His name will not even begin to express my gratitude.

Please keep me in your thoughts and in your prayers.

In Xt,

Tom

Thomas E. Havel

MAR-HAVL 000121

The Marianists

7500 Chaminade Ave. • Canoga Park, Calif. 91304 • (213) 347-8300

chaminade
preparatory

August 19, 1971

Very Reverend Bertrand Clemens, S.M.
Provincial of the Province of the Pacific
Marianist Provincial Residence
P.O. Box 937
Cupertino, California 95014

Dear Father,

The following is my "State of Disorder Message". Please forgive the presentation! It will probably be disjointed and confusing.

As of today, I still do not have an acceptable place to stay in Washington. In June, I wrote to the Jesuits at Georgetown. They had no room; but recommended that I write the Vicar General of the Archdiocese of Washington. Bishop Herrmann, the Vicar General, suggested the White Fathers and the Carmelite Priory. The White Fathers' Residence is filled and I have not received a reply from the Carmelite Priory.

Ed Wong gave me several leads after I told him about my plans. Holy Child Academy and Ursuline Convent, which he recommended, both were unable to help.

DeSales Hall (Seminary of the Oblates of St. Francis de Sales) did give me a place to stay. But the Seminary is in Hyattsville, Maryland. This is at the opposite end of Washington and commuting time would be about an hour, if I have a car, and longer if I use public transportation. This is too much time to take away from classes and studying, especially during my first year which has a very crowded schedule. Besides, one of the Medical Students, with whom I was corresponding to buy a microscope, wrote that traffic is very difficult and that parking, especially around Georgetown, is impossible. Also, the money which I originally planned to spend on a car (circa \$2,000.00) seems like too much of an expense, especially with all the other expenses that will be coming along. I did tentatively accept residence at DeSales Hall; so I will have a place to stay while looking for better lodging.

Br. Roger suggested that I write the Head of Instruction for each of the Provinces and see if any other Marianist is going to Georgetown this year. So far I have had only one negative reply from Br. Jansen!

Stone Ridge - School of the Sacred Heart, recommended by Holy Child Academy, offered me residence if I would teach eight hours of religion a week! I refused because of the conflict in schedule; but kept the lines open for future reference.

MAR-HAVL 000122

The Marianists

7500 Chaminade Ave. • Canoga Park, Calif. 91304 • (213) 347-8300



chaminade
preparatory

Br. Hugh Hoganson, while he was back in New York, talked to the Redeemptorist Provincial. He suggested that I write Holy Redeemer College. They too were full; but suggested that I write the Theological College. I wrote there the first of this week; but the reply has not returned yet.

While I was at Santa Cruz, I spoke to Father Hughes about my problems in finding a place to stay. I asked his help; but there was no reply for several weeks. Then I wrote him; but still no reply. He called Br. Frank Fanger and I asked if anything had developed. He had been working on it; but he didn't have anything concrete. I will probably call him in a day or so to see if anything turned up.

All the above mentioned religious houses are from 15 to 30 minutes driving time away from Georgetown. They will all require some kind of transportation. Again, a medical student from Georgetown discouraged traveling any distance or even owning a car. I checked into a Catholic family in the area that offered rooms; but they had none. I also wrote to a family, named Goldblatt, whom I had met while ^{they were} visiting their daughter here in Calif. They have a home near Georgetown and at that time offered me a place to stay. I wrote to them yesterday to see if their offer is still open. I am sure that I could find an acceptable room near the Georgetown campus; but I will have to be back there and look around personally.

The big disadvantage to living near campus is that I would not be living in a religious community; and this is something that I personally do not favor. Its bad enough not having a Marianist community nearby; but no community at all is even worse. However, considering the disadvantages of commuting in Washington, the expense of buying a car, and especially my complete ignorance of the area, it might be better to go back and find a room near campus for the first semester or first year. I can make arrangements to say Mass at the University Chapel and maybe strike up a friendship with other religious living on campus or nearby. Maybe, after they see that people from California wear shoes and use a knife and fork at table, the Jesuits or another religious house near by might take me in. I would very much like to hear your thoughts on this matter. If you want more information, I can call or even come up and see you.

What do you want me to do about the car that I am using? It is owned by the Province but I pay the insurance on it. After September 1st my insurance will expire. It is a 1963 Chevy. I runs well but uses quite a bit of gas and oil. I has over 100,000 miles on it also. I will probably leave it at Serra and give the keys to Br. Ed. Carey.

I hope you have received a cheque from my father. He said that he had send you a three thousand dollar cheque about the first of July.

The Marianists

7500 Chaminade Ave. * Canoga Park, Calif. 91304 * (213) 347-8300

MAR-HAIL 000123



chaminade
preparatory

Right now the papers on my Federally Insured Student Loan are being prepared. The Bank of America sets a limit of one thousand dollars rather than fifteen hundred dollars; so I will be five hundred dollars short in my outside income from that source. I would ask you to talk to Br. Charles Miller and have him send me a cheque to cover the following expenses:

| | |
|---|-------------------|
| Tuition for 1st semester | \$1400.00 |
| Insurance for the year (health) | 31.00 |
| Partial board (2 meals per day for a semester) | 268.00 |
| Books (approximately) | 200.00 |
| Lab coats and gowns (approximately) | 75.00 |
| Microscope | 250.00 |
| Room (appromimately \$75.00 per month for first five months) | 375.00 |
| Air plane ticket (American Airlines August 28th, 10:40 p.m. one way) | 155.00 |
| Pocket money and transportation fares laundry etc. \$35.00 per month for 5 months | 175.00 |
| | <u>\$ 2929.00</u> |

This seems like alot but some of the expenses will be eliminated for the second semester.

Since the loan will not come through for several weeks, I would like a cheque to cover the full amount. Then when I get the loan I will forward it to Brother Charles.

I plan on flying out August 28th in the evening. School starts September 8th so I will have a little over a week to get settled and find a place to stay. It will also give me a chance to go to Baltimore and meet the Marianist communities there.

Did you know that I was in the hospital about two weeks ago for three days? (St. John's Hospital in Santa Monica). If your didn't, you sure ~~would have~~ ^{will} when the bill arrives (approximately \$700.00)! That was for the hospital alone; the doctors donated their services! I was having these very severa head aches for about two weeks and they were afraid that I might have some kind of aneurysm. But it was an allergic histomine reaction. So now I am taking some medication to prevent the reaction. I don't know if I am covered by any policy that you have for Marianists. If there are any questions, I'll be glad to help. I figured that the \$31.00 for student health insurance is a cheap price to pay for the protection; that is why I included it in my expenses.

My stay at Santa Cruz was very rewarding. It was a pleasure to live with the Novices and Fr. Charlie. I also enjoyed the company of Fathers Tredtin and Fee; they even more than the reading brought me closer to the Marianist spirit and heritage.

The trips into the mountains with the groups from Chaminade were some of the best in many years. Both the trips and the boys

The Marianists

MAR-HAUL 000124

7500 Chaminade Ave. * Canoga Park, Calif. 91304 * (213) 347-8300



chaminade
preparatory

were well worth the effort. It was an especially fine group of boys that went on the trips this year.

I suppose that you have heard that Jack McNeil got appointed to the University of Constance in Germany for a two year post-doctoral fellowship. Now maybe he will finish his doctoral work.

Please convey my congratulations and promise of continual prayers to Steve Tutas. It will be hard to call him "Good Father"; but it will be a great privilege and honor to do so.

Also give my regards to all in the house; and, if you see my Novice Master, tell him that I am trying to stay on the straight and narrow. I was very impressed by the caliber of the novices under his guidance, especially the ones that made first vows last week.

Also please, give Roger all the gory details of my housing difficulties. He wrote to get my permanent address for the personal list. I probably won't have one for two more weeks; but as soon as I get it I will send it to him.

You will hear from me again, as soon as I get settled in Washington, if not sooner.

Yours in J.M.M.

Tom

Thomas Havel

P.S. Please have Brother Charles forward the cheque to cover my expenses as soon as possible. I have to pick up my ticket on Thursday of next week.

MAR-HAVL 000125

The Marianists

7500 Chaminade Ave. • Canoga Park, Calif. 91304 • (213) 347-8300

May 3, 1971

Reverend Thomas Havel,
The Marianists
14830 South Van Ness Avenue
Gardena, CA 90249

Dear Father Havel:

This letter is to assure you that the Society of Mary (Marianists) approves and encourages you in your studies of medicine and psychiatry. The Society is very pleased that you will pursue these studies at Georgetown University, beginning in the fall school year of 1971.

There are two items we wish to bring to your attention as you begin your studies at Georgetown:

1. The Society of Mary will assist you financially, but only to the sum of \$1,500 to cover your room and board,
2. The Society is willing to assist you as mentioned above, provided that you are able to secure from sources outside the Society of Mary the funds to cover tuition, equipment, transportation, and other needs, other than room and board, which your schooling at Georgetown will entail.

Again we do approve of your studies and encourage them, but on the conditions given above.

Sincerely yours in J. M. J. ,

Very Rev. Bertrand E. Clemens, S.M.
Provincial Superior

MAR-HAVL 000126

C
O
P
Y

May 3, 1971

Reverend Thomas Havel
The Marianists
14830 South Van Ness Avenue
Gardena, CA 90249

Dear Tom,

Enclosed with this letter is a formal letter which you requested that I write to you, so that you could submit it to the officials at Georgetown. I have tried to make it as formal and as pointed as possible, since this is what I thought you wanted me to do. If the letter is not satisfactory, do not hesitate to make changes and additions on the copy, return it to me, and I will make sure that you get the type of letter that you need and desire.

You also asked that I would put in writing your desire and intention to pay back to the Society of Mary the \$1,500 granted you annually for room and board while you are studying at Georgetown, before you should become a member of the Society of Mary, if eventually you would decide not to join the Society of Mary. I believe that this letter is sufficient as far as having this idea in writing. If there is anything that you would wish to have stated differently, do not hesitate to write to me.

I have tried, Tom, to put into writing in these two letters what I thought was your desire and our agreement after our conversation at Chaminade Prep. Do not hesitate to write and let me know if I have not understood something exactly as you thought or that we agreed.

It was wonderful seeing you again, and I appreciate very much your taking out time to come to Chaminade to talk to me. I always enjoy very much our visits together, and look forward to them.

Thanks, Tom, for all you are doing for the Marianists especially at Serra. This is more deeply appreciated than you can realize. We do hope with

MAR-HAUL 000127

Reverend Thomas Havel
Page 2
May 3, 1971

God's grace and our Blessed Mother's very special intercession that in the not-to-distant future you will be a professed member of the Society of Mary. This is something that I personally and I know all the Brothers in the Province desire and pray for. May God bless you.

Sincerely yours in J. M. J. ,

Reverend Bertrand E. Clemens, S.M.

C
O
P
Y

MAR-HAVL 000128

For Taster

28th of December 1970

Rev. Father Vincent Vasey, S.M.

Dear Father Vasey,

In its meeting of December 20th, 1970, the General Council considered the request of Father Bertrand Clemens, S.M., Provincial of the Pacific Province, to make application for an indult which would permit the Reverend Thomas E. Havel, Jr., priest of the Archdiocese of Los Angeles, to make his novitiate in the Society of Mary while pursuing secular studies on a full time basis.

Because of the qualities of Father Havel and because of the exceptional circumstances in his case it is advisable that he follow a special novitiate program as drawn up by Father John Bolin, Novice Master of the Pacific Province. The General Council endorses this arrangement. It is also advisable that the special program be undertaken while Father Havel is still engaged in his special secular studies. The General Council also endorses this arrangement under the following conditions:

- 1) That the duration of the novitiate be at least one full year.
- 2) That all vacation periods (Christmas, Easter, summer) be devoted full time to the novitiate program.
- 3) That at the end of one full year both the novice and the team of religious responsible for its fulfillment evaluate the program completed to that date. If the program has not been covered to the satisfaction of both the novice and the team, the novitiate should be prolonged (but not beyond a second full year) until the program is achieved to the satisfaction of the novice and the team.

The General Council's reasons for endorsing these arrangements are the following:

- 1) The course of studies that Father Havel is pursuing (medicine with a specialization in psychiatry) are of such a nature that a full year's interruption would make its resumption very difficult.
- 2) The close association of this priest with a Marianist community (living within it and acting as chaplain) for more than a year has already provided an exceptional head start for the proposed novitiate program.
- 3) The men who have lived with Father Havel are confident of his ability to undertake properly and successfully a novitiate program jointly with a program of secular studies.

With every best wish, I am,

Fraternally yours in J.M.J.,

MAR-HAVL 000129

Thomas A. Stanley, S.M.
Assistant General

November 28, 1970

Reverend Thomas Havel
Marianist Community
Junipero Serra High School
14830 South Van Ness Avenue
Gardena, CA 90249

Dear Tom,

I just wanted to let you know that Father Steve Tutas wrote to Father Vasey on November 12 asking him to request of the Sacred Congregation a dispensation for you from the canonical novitiate. I will keep you abreast of developments as we get them. I have no idea how soon we will hear from the General Administration or from the Sacred Congregation. But I want to assure you that we will keep in touch with you as soon as I get any information. I hope all is going along very well with you in school as it has been. We appreciate all you are doing for the community at Serra and all you mean to the Brothers. It was good visiting with you when I was in Los Angeles in early November. You are in our prayers; keep us in yours.

Sincerely yours in J. M. J. ,

Reverend Bertrand E. Clemens, S. M.

MAR-HAVL 000130

November 12, 1970

Reverend Vincent Vasey, S.M.
Curia Generalizia Marianisti
Via Latina 22
00179 Rome, Italy

Dear Father Vasey,

At this time, at the request of Father Clemens, I am writing to request that an applicant for admission to the Society of Mary, Father Thomas Havel, be dispensed from the required canonical novitiate and that the proposed program of preparation for the first profession of vows in the Society of Mary presented here be approved.

The Reverend Thomas E. Havel, Jr., was born October 12, 1937, in Blue Earth, Minnesota and was baptized there on October 27.

After attending schools in Minnesota, Nebraska and California, he entered the Los Angeles Archdiocesan Seminary, September 1955 and was ordained to the priesthood by James Cardinal McIntyre on May 3, 1963.

After serving as Assistant Pastor in two parishes of the Archdiocese from 1963 through the summer of 1969, he was granted a leave of absence from the Archdiocese for the purpose of living in a Marianist community while considering the possibility of applying for admission to the Society of Mary.

The leave of absence was granted for one year beginning August 1, 1969. Under date of February 27, 1970, the Archbishop of Los Angeles stated "We are most willing to continue Father's leave of absence in order that you may receive him in your Novitiate, if you be so disposed."

From August, 1969, Father Havel has been living in our Marianist community in Gardena, California, sharing the priestly responsibilities for the community with Father Frank Campanella, S.M.

MAR-HAVL 000131

Reverend Vincent Vasey, S.M.

Page 2

November 12, 1970

In a letter dated March 6, 1970, Father Havel formally requested admission to the Novitiate of the Society of Mary.

In reviewing Father Havel's application for admission, the Provincial Administration was impressed by the recommendations received from both the Archdiocese and the Gardena Marianist Community.

In the meeting of March 19, the Provincial Council approved Father Havel's request for admission to the Society of Mary. In his letter to Father Havel dated March 20, Father Clemens confirmed a proposal he had made previously, that the Province would work out a special novitiate program and present this to the Sacred Congregation of Religious in Rome for approval.

You will recall that I wrote you about this in my letter of April 14 which you answered on April 22, inviting me to present the proposed program. Later, when I was in Rome, you gave me further counsel on this.

Subsequently, Father Clemens was advised to request a dispensation from the novitiate for Father Havel. I am enclosing a copy of Father Clemens's letter to Father Havel.

I am also enclosing a copy of the proposed program prepared by Father Bolin.

Our reasons for requesting approval of this exceptional program are as follows:

1. Father's personal spiritual life is exceptional. He has achieved a human and Christian maturity superior to other candidates. The proposed program of preparation for the profession of vows is designed to emphasize an intensified growth in the religious life according to the Constitutions of the Society of Mary.
2. Father Havel is presently pursuing a course of studies in medicine with an eventual specialization in psychiatry. It would be very difficult for him to interrupt his studies in order to make a canonical novitiate. His age and university requirements make it highly advisable that he continue his course of studies without interruption.
3. It is our conviction that Father Havel will be able to master the points included in Father Bolin's proposed program by guided study.

MAR-HAVL 000132

Reverend Vincent Vasey, S.M.

Page 3

November 12, 1970

4. We recognize that Father Havel has already received a definite Marianist orientation by participating in province retreats and living in a Marianist community, not simply passively but quite actively as a chaplain to the community.

We would like to have this program approved for the benefit of Father Havel himself, but also for the good of the Society of Mary. Such an approval would demonstrate that the Province is able to offer a program that is adequate and appropriate to the candidate.

You will know best how to present this effectively. If you need more information, I would be happy to give you further documentation or attempt to answer specific questions. I shall be in California until November 30 when I leave for the next meeting of the Preparatory Commission.

Thank you for your help in preparing this request.

Sincerely,

Reverend Stephen R. Tutas, S.M.

Enclosures

C
O
P
Y

MAR-HAUL 000133

July 17, 1970

Reverend Thomas Havel
Junipero Serra High School
14830 South Van Ness Avenue
Gardena, CA 90249

Dear Tom,

When we spoke together during the time of the Azusa retreat, I mentioned to you that I would speak to the Major Superiors and canonists in Dayton when I met with them concerning your novitiate. I did have an opportunity to talk to several people. The Major Superiors were not able to help me in any way, since they did not have any similar situation concerning men entering their congregations at this time.

I did talk to Father Alar McCoy. He is presently the Provincial of the Franciscans in California and was president of the Canon Law Society of America at one time. He is quite a good canonist. I explained to him your situation, and his advice to me was that we should write to the Sacred Congregation asking for a dispensation from the novitiate for you. He said that we would have to come up with some kind of a program for you, which would naturally replace the novitiate, but that if we could get a dispensation from the novitiate as such, then we would not be held to the time limit which the novitiate demands and also to that obstacle which we have encountered of formal studies. Father Bolin has not arrived at the Provincial Administration yet. He is on his way back from St. Louis, Missouri, to Cupertino now. Father Tutas is in Rome working with the Preparatory Commission in preparation for the next summer General Chapter. When Father Tutas returns and when Father Bolin is here, I will work with them on preparing a letter which we shall submit to our Procurator General to the Sacred Congregation asking for this dispensation for you. Father McCoy thought that we would have success in getting a dispensation, because you have had seminary and are now an ordained priest. I will certainly keep in touch with

MAR-HAVL000134

Reverend Thomas Havel

Page 2

July 17, 1970

you as we progress along the way of petitioning this dispensation. I think Father McCoy's idea of asking for a dispensation from the novitiate in your case is a good one. However, we shall make sure that you would get time to study the Society of Mary as you desire, even though we can get a dispensation.

It was good seeing you at the retreat and talking with you. The Brothers at Serra are delighted with you and having you with them. Thanks for everything, Tom. You are in our prayers.

Sincerely yours in J. M. J. ,

Father Bertrand E. Clemens, S. M.

COPY

MAR-HAVL 000135

For Discussion, revision, additions, subtractions, etc.

The following is a general description of the program of formation proposed for Fr. Thomas Havel in preparation for profession of vows in the Society of Mary:

Part One: General Plan

1. The program will begin with an OPENING RETREAT under the direction of the Director of Novices.
2. The main part of the formation program will center around a DETAILED READING PROGRAM which will attempt to give both an overview of religious life in the Society of Mary, and an in-depth study of specific areas of concentration concerning the most important points of the overview.
3. Each month one of the members of the Formation Team will meet with Fr. Havel for a DIRECTION-DISCUSSION period treating the material being studied and Father's progress in preparing for profession.
4. Four times during the year there will be a QUARTERLY RETREAT for Father at the Novitiate, under the direction of the Director of Novices or one of the members of the Formation Team.
5. Finally, there will be a PRE-PROFESSION RETREAT of some length.

Part Two: Specific Areas of Reading-Study-Direction

The following areas will be treated in the overview and the in-depth treatment:

1. Marianist Documentation
2. History of the Society of Mary and of its Constitutions
3. Marianist Spirituality
4. Callings, Poverty, Obedience and Stability: Evangelical Living in the S.M.
5. Community of Life
6. Community of Worship
7. Community of Apostolic Action
8. Categories, Offices, Governmental Structures
9. Family of Mary
10. Theological-Scriptural-Pastoral Renewal

Part Three: Sources

There will be bibliographies provided for each area of study-discussion-direction, with core readings and supplemental readings taken from S.M. documentary sources and from recent books and periodicals.

Part Four: Formation Team

The direction of this formation program will be undertaken by a team composed of: Fr. John Solin, Director of Novices and Chairman of the Team; Fr. Bertrand Clemens, S.M.; Bro. Roger Richter, S.M.; Fr. Stephen Tutus, S.M.; Fr. Joseph Stefanelli, S.M., and Bro. Edward Carey, S.M.

May 18, 1970

Reverend Thomas Havel
Serra High School
14830 South Van Ness Avenue
Gardena, CA 90249

Dear Tom,

Many thanks for your letter of May 10.

In view of the fact that it is not possible to interrupt your program of studies, my suggestion is that we follow through with the series of workshops and guided reading that I had originally prepared as a possible novitiate program. Evidently, the program cannot be authorized as a canonical novitiate program, but would serve as a progressive preparation for your formal entry into the Society of Mary.

We can discuss this in more detail when you come to Cupertino. I shall be away from the Provincialate from June 13-21, conducting a retreat. I hope to see you either before or after that date.

Be assured you are in my thoughts and prayers.

Sincerely,

Father Stephen R. Tutas, S.M.

MAR-HAVL 000137

C
O
P
Y

is the
overflowing
of oneself
into the lives
of others

is dependent on one step
following immediately upon
the other.

One does not take a year off
between undergraduate studies
& Med School, especially at
my age!

After June 10th I will be
free for 2 weeks before summer
school begins. I hope to see
you & Fr Clemens during that
time. And I hope some mutually
agreeable can be worked out.

Until then
yours in Xt,
Tom.

+

May 10th

Dear Steve,

Please forgive the delay in
answering your letter.

The reply from Rome was
hardly surprising. In fact
Fr Clemens & I talked about
alternatives when I last saw

him. He felt very confident
that something could be worked

out. Unfortunately my course of
studies is very compact & the
success of the whole program

April 29, 1970

C
O
P
Y

Reverend Thomas Havel
Serra High School
14830 South Van Ness Avenue
Gardena, CA 90249

Dear Father Havel,

I have been in correspondence with our Procurator General about a proposed novitiate program for you.

We had worked out a program consisting of a series of workshops here at Cupertino during the summer and semester breaks. However, our Procurator General made several observations including the following:

1. Even when an exception is made for a single individual, the novitiate should last a full year.
2. Other studies leading to degrees of any kind are forbidden.

It would seem, then, that it will be necessary for you to interrupt your studies. The question is when you would prefer to do this.

I would like you to consider this and let me know your preference.

Sincerely,

Father Stephen R. Tutas, S. M.

MAR-HAVL 000139

March 20, 1970

Reverend Thomas Havel
Junipero Serra High School
14830 South Van Ness Avenue
Gardena, CA 90249

Dear Tom,

I am very happy to write you that the Provincial Council in a meeting of March 19 accepted you into the novitiate of the Society of Mary. My sincerest congratulations, Tom.

As I mentioned to you in an earlier letter, if you were accepted into the novitiate, then we would write to the Sacred Congregation in Rome for a special novitiate program for you. In a previous letter to you, I outlined in general what might be such a program. As soon as we have been able to work out a plan to submit to the Sacred Congregation, we will inform you of this. I imagine that it would envisage your staying at Serra while continuing school, but reporting to Cupertino during vacations and over holidays for special instructions. At any rate, we will keep in touch with you about this program as it is developed.

We are very happy, Tom, that you applied to the novitiate and have been accepted for the novitiate of the Society of Mary. The Brothers have been delighted with you and your presence at Serra. You mean much to the Brothers, and you will be of great help to them.

I would recommend that you continually do some reading of the documents of the Society of Mary. If I can be of further help in this regard, do not hesitate to let me know.

Again, congratulations, Tom. You are in our prayers. Do continue to remember us in yours. May your Easter be a blessed and joyous one.

Sincerely yours in J. M. J. ,

Father Bertrand E. Clemens, S.M.

MAR-HAVL 000140



JUNIPERO SERRA HIGH SCHOOL

14830 SOUTH VAN NESS AVENUE • GARDENA, CALIFORNIA 90249 DAVIS 4-6675 FA 1-0377

CONDUCTED BY THE MARIANISTS

March 9, 1970

Very Reverend Bertrand E. Clemens, S.M.
Province of the Pacific
P.O. Box 937
Cupertino, California 95014

Very Reverend Father:

It is with a great deal of personal pleasure that I write this letter as Director of the Serra Community on Father Thomas E. Havel's application to enter the Novitiate and the Society of Mary. Over the past seven months Father Tom has been an outstanding example of Priest, Brother and an aid to our Community, spiritually, fraternally. Moreover, he has been a source of support to us as a community in all of our endeavors to service the Brothers, Students and the Family of Mary. We are all much impressed with his religious spirit and his manliness in the performance of his daily duties of student and fellow Community member. Indeed we are especially blessed to have a man of Father Tom's ability, experience and character to desire to join the Society of Mary.

Though I write this as Director of the Serra Community I know I speak for all the Brothers in the Community of the happiness with which we receive this news of Father Tom's wishing to join us officially. For a fact he has truly been with us in mind, in spirit and in action these past seven months. We feel he is one of us now.

Please know that we shall pray for his speedy entrance into the Society of Mary and we pledge to do anything we can to assure Father Tom of becoming one of us real soon.

As always,

Brother Edward Carey, S.M.

Brother Edward Carey, S.M.
Director

MAR-HAVL 000141



JUNIPERO SERRA HIGH SCHOOL

14830 SOUTH VAN NESS AVENUE • GARDENA, CALIFORNIA 90249 DAVIS 4-6675 FA 1-0377

CONDUCTED BY THE MARIANISTS

March 6, 1970

Very Reverend Bertrand E. Clemens, S.M.
Province of the Pacific
P.O. Box 937
Cupertino, California 95014

Very Reverend Father:

With this letter I formally request admission into the Novitiate of the Society of Mary, Province of the Pacific.

I have known the Marianist Community in Canoga Park, California since 1963. And many of the Marianists I met there are personal friends. Also I participated in several school programs (e.g., the summer hiking trips) while Assistant Pastor in St. Bernardine of Siena Parish, Woodland Hills, Calif. I have always been impressed with and admired their spirit, especially their Christian friendliness and charity.

Now, with your permission, I have lived with the Gardena Community of Marianists for over seven months. This short stay and the spirit with which I am accepted into this community have convinced me more than ever that Christ has chosen a religious life in the Society of Mary for me.

I find myself both by temperament and the grace of God most happy and suited for religious community life as found in the Society of Mary. These few short months have strengthened my spiritual life and given me much happiness. I am particularly appreciative of the opportunity, provided by the Superiors of the Society and the Society's own commitment to an "universal apostolate," to exercise my God given talents in a way that will be best in serving God, His Church, the Society of Mary, and all men.

For these reasons, I request admission into the Novitiate of the Society of Mary.

Faithfully yours in Christ,

Thomas E. Havel

Rev. Thomas E. Havel

MAR-HAVL 000142

CHURCH OF ST. PHILIP THE APOSTLE

151 SOUTH HILL AVENUE
PASADENA, CALIFORNIA

March fifth, 1970

Dear Father Clemens:

The Reverend Thomas Havel has asked me to write this letter.

Father Havel was a valued and esteemed assistant here for two years until September of 1969. He was most exacting in the fulfillment of his priestly and pastoral duties. He showed initiative and enterprise in his many-sided apostolate here, including the chaplancies of Cal Tech and of Serra International.

He was properly submissive, amenable to suggestions, sensibly progressive in the new approaches in the theological disciplines. He was affable but not effusive in his contacts with the laity. His presence in the household was a benediction in his fellowship with his brother priests.

We pray for him blessings and joys in the years ahead.

Sincerely,

P a s t o r

Very Rev. Bertrand Clemens, S.M.,
Cupertino, California.

MAR-HAVL 000143

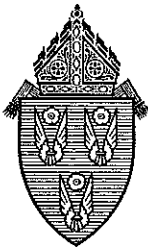

ARCHDIOCESE OF LOS ANGELES
1531 WEST NINTH STREET
LOS ANGELES, CALIFORNIA 90015

DUnkirk 8-8101

February 27, 1970

Very Reverend Bertrand Clemens
MARIANIST PROVINCIAL RESIDENCE
P.O. Box 937
Cupertino, California 95014

Very Reverend and dear Father Clemens:

We are in receipt of a letter from Father Thomas E. Havel of this Archdiocese. He requests that a letter from this jurisdiction indicate our willingness that he enter the Novitiate of the Marianist Community.

At present, Father Havel is on leave of absence from the Archdiocese for the purpose of living with members of your Society in order to determine his desire to become a Marianist. We are most willing to continue Father's leave of absence in order that you may receive him in your Novitiate, if you be so disposed.

Enclosed please find a certificate of Father's ordination.

With kindest personal regards, I am

Very sincerely yours,

+ *Timothy Manning*

TIMOTHY MANNING
Archbishop of Los Angeles

M
Encl.

MAR-HAVL 000144

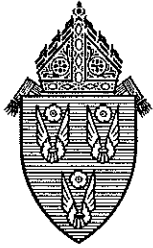

ARCHDIOCESE OF LOS ANGELES

1531 WEST NINTH STREET
LOS ANGELES, CALIFORNIA 90015

DUnkirk 8-8101

February 27, 1970

Reverend Thomas E. Havel
JUNIPERO SERRA HIGH SCHOOL
14830 South Van Ness Avenue
Gardena, California 90249

Dear Father Havel:

In answer to your letter addressed to His Excellency, Archbishop Manning, please be advised that the documents which you requested were forwarded by His Excellency to Father Bertrand Clemens.

If there is any further assistance we may give you in this regard, please do not hesitate either to write personally or have Father Clemens indicate what is necessary.

With kindest personal regards, I remain

Sincerely yours in Christ,

A handwritten signature in cursive script that reads "John A. Rawden".

Reverend Monsignor John A. Rawden
Chancellor

M

MAR-HAVL 000145

ST. JOHN'S SEMINARY

CAMARILLO, CALIFORNIA 93010

5012 EAST SEMINARY ROAD

TELEPHONE
AREA CODE 805
482-2755

February 27, 1970

The Very Reverend Bertrand Clemens, S.M.
Marianist Provincial Residence
Box 937
Cupertino, California 95014

Very Reverend and dear Father Clemens:

The enclosed transcript of credits is being sent to you at
the request of

REVEREND THOMAS EARL HAVEL.

A transcript of his college credits is being mailed separately
from St. John's College.

Faternally yours in Christ,

Charles E. Miller, C.M.

(Rev.) Charles E. Miller, C.M.
Registrar

MAR-HAVL 000146

February 27, 1970

The Very Reverend Bertrand Clemens, S.M.
Marianist Provincial Residence
Box 937
Cupertino, California 95014

Very Reverend and dear Father Clemens:

The enclosed transcript of credits is being sent to you at
the request of

REVEREND THOMAS EARL HAVEL.

A transcript of his college credits is being mailed separately
from St. John's College.

Fraternally yours in Christ,

(Rev.) Charles E. Miller, C.M.
Registrar

Hi Tom,
Hope all goes well. God bless
you.
Fraternally,
Charley

MAR-HAVL 000147

C
O
P
Y

February 16, 1970

Reverend Thomas Havel
Serra High School
14830 South Van Ness Avenue
Gardena, CA 90249

Dear Tom,

Just after I had written to you, I received your curriculum vitae. Many thanks for this. I am sure this will come in very handy when we write to Rome for an indult for you.

If you have any trouble in securing any papers for application to the novitiate or have any questions in this regard, and if I can be of help to you, do not hesitate to write to me. I assure you that I am very happy that you are planning to join the Society of Mary. You will be able to contribute much to the Brothers and to the Society.

You are daily in our prayers keep us in yours.

Sincerely yours in J. M. J.,

Father Bertrand E. Clemens, S.M.

MAR-HAVL 000148

February 10, 1970

Reverend Thomas Hovel
Junipero Serra High School
14830 South Van Ness Avenue
Gardena, CA 90249

Dear Tom,

In my recent letter to you, I mentioned that I would bring to the attention of the Provincial Council the fact that it seemed advisable in your case to write to the Sacred Congregation of Religious for an indult concerning yourself and the novitiate, if you formally request a novitiate and this is approved by the council. We had a council meeting yesterday, and I discussed this matter with the council. The council agreed with me on this proposal.

Now, this would entail, Tom, that you would make a formal request to enter the novitiate of the Society of Mary. To do this there are a number of papers that are required. My suggestion would be that you ask Brother Ed Carey, the director, for a set of papers for the novitiate. If he should not have this set of papers which you are to complete and send to us, just let me know, and I can send you a set. The papers are documents that you will be asked to submit to us requesting entrance into the novitiate are: Your formal letter of request to enter the novitiate and in this letter you give the reasons for your desire to enter the Society of Mary; a questionnaire of information about yourself is one of the papers that Brother Ed Carey will give you; then there is required the MMPI psychological test; a medical report is required and this paper can be furnished to you by Brother Ed also; a paper giving your parents consent is required; we would also need a letter from the Archbishop granting you permission to do this and a recommendation from him or someone else in the Diocese; a transcript of your credits from college is also required; if you can get a document showing your ordination this will include automatically other documents which are normally required but which you would not have to get such as baptismal certificate, confirmation certificate, and marriage certificate of your parents; a letter of recommendation by

MAR-HAVL 000149

Reverend Thomas Hovel

Page 2

February 10, 1970

Brother Ed Carey, and finally a passport size photo of yourself. This list of needed documents sound rather formidable, but I am sure once you have the papers needed to aid you in getting this information to us, the real job will not look too difficult. I believe it would be well if you could begin securing these documents soon, for often there are delays which would then hold up the process of acceptance to the novitiate. Once the Provincial Administration has all these documents, then your request is considered in council. If the decision is favorable, then we would immediately write to Rome to secure an indult for you for the novitiate as I described in the previous letter.

In my previous letter I had asked you to send me a curriculum vitae, and I would still appreciate if I could get this from you, Tom. This will help us when eventually we would be writing for the indult, once you are accepted into the novitiate formally.

I am sure that Brother Ed Carey or Brother Jack McNeil could help you in many ways to secure these documents and this information. If there is anything further that I can help you with, do not hesitate to write.

I want to assure you again, that we are very happy that you are planning to request this entrance into the novitiate. We shall look forward to seeing your request. The Brothers at Serra are very fond of you and appreciate all that you are doing for them as a person and as a priest. This is greatly appreciated by all of us. We do hope that you will find religious life and community life among the Marianists most satisfying and beneficial. I am sure that you will. You are daily in our prayers keep us in yours.

Sincerely yours in J. M. J.,

Father Bertrand E. Clemens, S.M.

MAR-HAVL 000150

ST. BONAVENTURE



Feb 10, 1970

Dear Father,

Enclosed is a list of the dates & places you asked for. If any further information is required, please let me know.

Thank you again for your help in this matter & in everything.

yours in Xt
Tom

J m J.

Tom Havel

logbook books

→ 69-70
70-71

2-3 week
- 3 week
- 2-3 week
- frequency + end of summer
- 3 week
- 2 week
- summer of 1971 - whole summer
Loyola: grad - med:
(undergrad)

71-72
72-73
73-74
74-75

} straight medicine
(Medical School)
St. Louis, Mo.

logbook books

→ 75-76
76-77
77-78
78-79
79-80
80-81

} Internship
3-5 year of Post.

made Tom for Curriculum vitae 2-2-70

February 3, 1970

Reverend Thomas Havel
The Marianists
14830 South Van Ness Avenue
Gardena, California 90249

Dear Tom,

As I mentioned to you when we spoke together at Serra last week, I did consult with Father Joseph Stefanelli concerning your Novitiate. Father Joe made a suggestion which I plan to bring to the Council, and that is, that since you are already an ordained priest, I write to the Sacred Congregation of Religious through our General Administration asking for a very special Novitiate in your case, and to request and indult for this.

I would like to ask the Sacred Congregation that you spend parts of your summers and Christmas and Easter vacations in a formal Novitiate here at Cupertino like you suggested, and live in our community at Serra as you are doing now while still pursuing your studies. This would be exactly what you had suggested yourself. In order to do this, I would appreciate it if you could write to me at your earliest convenience and give me a listing of your previous schooling. The name of the grade school, high school, seminary and information that I could send to the Sacred Congregation. If you could also give me the date of your ordination, by whom, and where you served as a priest, I would pass on all this information to the Sacred Congregation. I am sure that they would want such a curriculum vitae.

We are having a Council meeting next Tuesday, and I will bring this to the attention of my council. I do expect the Council will go along with this suggestion. So if I could have this information on you at an early date, I would get off this request to our General Administration and the Sacred Congregation as soon as possible.

MAR-HAVL 000153

Father Thomas Havel
3 February 1970

2

If I have my facts correct, we could expect that you could have two or three weeks free at the beginning of this next summer and two or three weeks towards the end of this next summer free. You would also have the Christmas break of 1970 which would consist of about two or three weeks. Your semester week break would also be about two weeks. I believe you mentioned that you would have the whole summer free of 1971. I believe that such periods of time spent in a formal Novitiate setting of some kind would be acceptable to the Sacred Congregation. I will see what I can do in this regard.

It was good talking with you while I was at Serra. We are very happy that you are with us at Serra, and the Brothers do like you very much and appreciate you. We are very happy that you are thinking of joining the Society of Mary. Keep us in your prayers, Tom. You are in ours.

Sincerely yours in J.M.J.,

Father Bertrand E. Clemens, S.M.

MAR-HAVL 000154

*answered in part
by RDR*

May 22, 1969

Dear Father Clemens:

Forgive the delay in getting this letter to you. I had hoped to see you last Friday when I visited Serra but unfortunately you were ill and could not come down to the south land. I hope you are feeling better now.

Many things have happened since your last letter. After receiving your letter, my parents requested that I talk to my family pastor, Msgr. O'Flaherty, which I did. After a hour long walk and talk on the beach in Santa Monica, he gave his blessing and offered to recommend me to the Cardinal if I so wished. This conversation and its conclusion didn't do much about my own personal decision but it did put my parents more at ease about the whole matter.

I also talked to Fr. Henry Alker who has been giving me guidance in this vocational choice too. He is a secular priest of this diocese and a saint in my opinion. He too was very receptive of the plans we had discussed and also agreed to give his recommendation if I so wished.

The Vicar General and Chancellor, Msgr. Hawkes, was on vacation and will not return until June 1st. I thought that maybe nothing could be done until he had returned which was, to say the least, disappointing. But Msgr. Rawden, the Assistant Chancellor, agreed to see me. He was very receptive but said that the Cardinal would have to talk to several people first.

I figured that one of those people would be my pastor. So on Saturday, May 10th, I told him about my plans. He was not as enthusiastic as the others and was rather concerned

AAAR-HAVL 110015

2

about my leaving so early in June because of the difficulty in finding a replacement. So I agreed to remain until August 1st when my regular vacation started.

On Monday, May 12th, Msgr. Rawden called and told me "that I now had permission to write a letter asking for permission!!! Needless to say the letter was in the mail that very day. I figured that they would not get around to granting an interview until the first of the next week. But on Ascension Thursday a letter came in the mail giving me permission to leave when ever I wished and to inform them of the date!!!!

Friday, May 16th, I stopped by the Chancery Office just to thank Msgr. Rawden for his help. But he insisted that I see the Cardinal. It was a very short but friendly interview. We agreed upon August 1st as the date of the beginning of my leave of absence.

So much for my leaving taking. I would also like to tell you about my progress in my academic pursuits, and request attending your retreat rather than the diocese's, and pose some question with regard to living at Serra etc.

First of all, academic pursuits: Last Wednesday, May 21st, I had an interview with Dr. Kadner, Head of Biology at Loyola. He mapped out a stiff course of studies which would complete my undergraduate work in two years. I then talked to Mr. L'Heureux, the Registrar. He was rather pessimistic because of my long absence from school. He thought that the schedule was too heavy for me without some preparation. But he did give me the form for admission. I have sent for my transcripts and when all is at Loyola, I am to call and have a conference with him and Fr. Mahon, Dean of Arts and Sciences.

MAR-HAV 000156

It will be impossible for me to attend summer school because of my commitment to stay in the parish. But I plan on getting the high school texts in biology, chemistry and math, and to review them somewhat during the six week to two month period between August 1st and the beginning of school.

I would like very much to attend one of the Marianists retreats this summer. As I understand it, one is in Southern California in June and one is in Northern California in August. The date for the June retreat conflicts with the time the other assistant has off for his retreat. So it would be to everyone's advantage if I could attend the August retreat. I was scheduled to make my retreat on June 23rd for the diocese. But by attending the August retreat, I will be able to attend the Serra Club convention which also begins on June 23rd. (I happen to be the chaplain for the Pasadena Serra Club.)

This happens to be a two day letter. After writing the first part, I happened to see Br. Jack McNeil. He told me that you were still in the hospital. I'm very sorry to hear this and you will be in my prayers for a speedy recovery.

I would pose my questions about living at Serra at this time. But rather I'll wait until you are feeling better. Perhaps if you visit the southland soon after you leave the hospital, we can arrange to talk down here. If not, I'll fly up sometime after you arrive home. I did have a nice talk with Br. Edward Carey, which was very helpful.

In reality this is the rough draft of the letter I'm supposed to send you. But rather than delay until I have time to retype it, I'm forwarding it to you as is.

I hope to see you soon.

Yours in Christ,

MAR-HAVL 000157

Tom Havel

Ps. Enclosed are copies of the correspondence with H. P., O. S. A.

CHURCH OF SAINT PHILIP THE APOSTLE

151 SOUTH HILL AVENUE
PASADENA, CALIFORNIA

two years in order
I would like to request a leave of absence ^{two years in order} to test this vocation.

This leave of absence is requested in the hope of becoming a Marianist; but, if God wills otherwise, it would be my fondest wish to return to this Archdiocese and resume my work as a parish priest.

to be able to
This letter may be sketchy and still leave some questions unanswered. If this can be remedied by further correspondence and/or a personal interview, I am at your disposal.

Respectfully yours in Christ

Thomas E. Havel

(Rev.) Thomas E. Havel

MAR-HAVL 000158

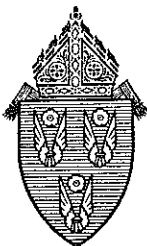

ARCHDIOCESE OF LOS ANGELES

1531 WEST NINTH STREET
LOS ANGELES, CALIFORNIA 90015

DUnkirk 8-8101

May 20, 1969

Reverend Thomas E. Havel
ST. PHILIP THE APOSTLE
151 South Hill Avenue
Pasadena, California 91106

My dear Father Havel:

This will confirm our conversation of last Friday. From this we note that you will arrange to commence your leave of absence on August 1st. We observe that Monsignor North is acquainted with this arrangement, and are hopeful that it will develop satisfactorily.

Praying for you all blessings, I am

Faithfully yours in Christ,

ARCHBISHOP
of
Los Angeles

M

MAR-HAVL 000159

CHURCH OF SAINT PHILIP THE APOSTLE

151 SOUTH HILL AVENUE
PASADENA, CALIFORNIA

May 20, 1969

His Eminence James Francis Cardinal McIntyre
Archbishop of Los Angeles
1531 West Ninth Street
Los Angeles, California 90015

Your Eminence:

Thank you very much for receiving me last Friday during my unscheduled visit to the Chancery Office. Your kindness and helpfulness in my desire to test my vocation with the Marianists is greatly appreciated.

This letter will also confirm August 1, 1969 as the date beginning my leave of absence from the Archdiocese agreed upon in our conversation.

Thanking you again for your kindness, I am

Respectfully yours,

Thomas E. Havel

Rev. Thomas E. Havel

MAR-HAVL 000160

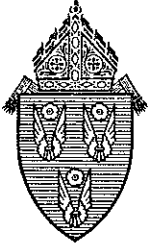

ARCHDIOCESE OF LOS ANGELES

1531 WEST NINTH STREET
LOS ANGELES, CALIFORNIA 90015

DUnkirk 8-8101

May 14, 1969

Reverend Thomas E. Havel
ST. PHILIP THE APOSTLE
151 South Hill Avenue
Pasadena, California

My dear Father Havel:

I am in receipt of your letter of May 13th, unsigned.

We have read your proposal with interest, and are willing to extend to you a leave of absence for a year's time on the condition that you will spend it with the Pacific Province of the Society of Mary as a trial period in the contemplation of joining that Society.

Please advise us as to when you plan to leave St. Philip's.

We are hopeful that you will prayerfully seek the best guidance in the prosecution of this contemplation, and with sincere best wishes, I am

Faithfully yours in Christ,

A handwritten signature in cursive script, reading "Francis M. Buckley".

ARCHBISHOP

of

Los Angeles

M

MAR-HAUL 000161

CHURCH OF SAINT PHILIP THE APOSTLE

151 SOUTH HILL AVENUE
PASADENA, CALIFORNIA

May 13, 1969

His Eminence James Francis Cardinal McIntyre
Archdiocese of Los Angeles
1531 West Ninth Street
Los Angeles, California 90015

Your Eminence:

On May 2, 1969 the Very Reverend Bertrand E. Clemens, S.M., Provincial of the Pacific Province of the Society of Mary, accepted my request to come and live in the community of the Society of Mary with the intention of taking vows and becoming a member of this religious order in due time.

This acceptance is the happy fulfillment of my hopes and prayers to become a Marianist. It has not been a recent idea with me. Even during my seminary days I seriously considered entering a teaching community. After ordination this idea continued and became centered on the Society of Mary. During my assignment to St. Bernardine of Siena ^{Parish}, Woodland Hills, I became very friendly with the Marianists at Chaminade High School. Father John McEnhill, S.M. was my spiritual director at that time and I did talk with him about my desire to join the Marianists; but no final conclusions were reached.

While in Woodland Hills and even after I was transferred to Pasadena, I remained on good terms with many of the priests and brothers and participated in many of their activities. The idea of being a Marianist remained. And after seven months of prayer, reflection and direction I made the decision which is contained in this letter. I feel called to try this religious life not only because of my great interest and desire to participate in their apostolate of Christian Education but also because I greatly admire their community life and spirit.

As was stated, these considerations have been made with the advise of my confessor and other priests whose judgments I value. Priests with whom I spoke and who encourage me in making my choice include, Msgr. Raymond J. Flaherty, Father Henry Alker, and Father John McEnhill, S.M.

*a copy of my
rough copy!*

*notably as a
Chaplain with
brothers & high
school students
on hiking trips*

MAR-HAVL 000162

SEP - 9 ANSD

PROGRESS NOTES

+

| DATE | Aug 12 th |
|------|---|
| | Dear Joe, |
| | It has been a very busy month for me. I am on Medicine at D.C. General Hospital. |
| | We are on duty every 3rd night. And I spend my other evenings catching up on my sleep. |
| | Enclosed is my financial statement for July. The insurance policy money is from a policy I had as a secular priest. Fr. Bueh had told me to use it as I see fit in my expenses. What I would like to do, since I have enough other income for the expenses of this year is to use the money to fly the two women I live & here in D.C. to the coast for the last 2 wks of my vacation in February. My folks have already agreed to let them stay & them while in Southern Calif. (You probably should interview them, since they are the best judges of my conduct in community for the past 3 yrs.!!) |
| | Art Lopez wrote me concerning my ideas on the Health Service of the Province. Again I must beg off from offering an opinion until I am in a better position to judge the true needs of the province & the resources available. - Please convey this |

NOTES CONTINUED:

DATE

to Art. Since I won't have time to write to him.

My progress are with the Province during this important time of year. - the newly professed, the perpetually professed, the new novices + the new assistant Provincial (there is not a better man than Ed.) and the new Heads of Spiritual Life + Apostolic Works.

Yours in Xt,
Tom

Thomas E. Havel, Jr.

October 12, 1937

Born:
Blue Earth, Minn.

October 27, 1937

Baptized:
Ss. Peter and Paul Catholic Church
Blue Earth, Minn.

May 1, 1944

First Holy Communion:
Ss. Peter and Paul Catholic Church
Blue Earth, Minn.

September 1943 - May 1946

Grammar School:
Blue Earth Public School
Blue Earth, Minn.

September 1946 - May 1948

Grammar School:
St. Margaret Mary's Catholic School
Omaha, Nebr.

September 1948 - December 1949

Grammar School:
St. Cecilia's Catholic School
Omaha, Nebr.

December 1949 - May 1951

Grammar School:
St. Monica's Catholic School
Santa Monica, Calif.

September 1951 - May 1955

High School
St. Monica's Boys' High School
Santa Monica, Calif.

September 1955 - May 1957

Junior Seminary:
Our Lady, Queen of the Angeles
San Fernando, Calif.

September 1958- May 1963

Major Seminary:
St. John's Seminary
Camarillo, Calif.

May 3, 1963

Ordination:
For the Archdiocese of Los Angeles
By: James Cardinal McIntyre
St. Vibiana Cathedral
Los Angeles, Calif.

May 1963 - August 1967

Assistant Pastor:
St. Bernardine of Siena Parish
Woodland Hills, Calif.

August 1967 - August 1969

Assistant Pastor:
St. Philip the Apostle Parish
Pasadena, Calif.

I have a Bachelor of Arts Degree in Philosophy which I received
in May of 1960.

MAR-HAVL 000165



Timotheus Manning
Dei et Apostolicae Sedis Gratia
Archiepiscopus Angelorum
in California

Dilecto Nobis in Christo _____ THOMAE E. HAVEL _____

Nos, considerantes tuam in Domino utilitatem, et rationes quas ad hoc Nobis exposuisti, salvis iure praescriptis circa ordinationis tuae titulum, praeviis etiam de tuis natalibus, vita, moribus ac studiis opportunis relationibus et testimoniis, a Nobis mature perpensis et recognitis, et causa novae incardinationis tuae ad _____ Societas Mariae - Marianistae _____ directis, ad tuam petitionem et instantiam, ex Nostra dioecesi Angelorum in California praesentium virtute te excardinamus excardinatumque declaramus. In nomine Patris et Filii et Spiritus Sancti. Amen.

Datum in Civitate Angelorum, sub signo sigilloque Nostris ac cancellarii Nostris subscriptione, anno Domini _____ 1972 _____, die vero _____ 10a _____ mensis _____ Maii _____.

+ *Timothy Manning*

ARCHIEPISCOPUS ANGELORUM IN CALIFORNIA

DE MANDATO REVERENDISSIMI ARCHIEPISCOPI

CANCELLARIUS

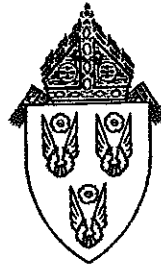

Timotheus Manning
Dei et Apostolicae Sedis Gratia
Archiepiscopus Angelorum
in California

Dilecto Nobis in Christo _____ THOMAE E. HAVEL _____

Nos, considerantes tuam in Domino utilitatem, et rationes quas ad hoc Nobis exposuisti, salvis iure praescriptis circa ordinationis tuae titulum, praevius etiam de tuis natalibus, vita, moribus ac studiis opportunis relationibus et testimoniis, a Nobis mature perpensis et recognitis, et causa novae incardinationis tuae ad _____ Societas Mariae - Marianistae _____ directis, ad tuam petitionem et instantiam, ex Nostra dioecesi Angelorum in California praesentium virtute te excardinamus excardinatumque declaramus. In nomine Patris et Filii et Spiritus Sancti. Amen.

Datum in Civitate Angelorum, sub signo sigilloque Nostris ac cancellarii Nostri subscriptione, anno Domini _____ 1972 _____, die vero _____ 10a _____ mensis _____ Maii _____.

+ Timotheus Manning

ARCHIEPISCOPUS ANGELORUM IN CALIFORNIA

DE MANDATO REVERENDISSIMI ARCHIEPISCOPI

CANCELLARIUS

MAR-HAVL 000170

SOCIETY OF MARY
(Marianists)
Box 586, Santa Cruz, California

Application for Admission to Novitiate Aspirancy Program (check one)

Please TYPE or PRINT information requested

Name in Full Havel, Thomas E., Jr.
Print (Family Name) (First) (Middle)
 PLEASE PRINT YOUR FULL LEGAL NAME DO NOT USE NICKNAMES

Address 18430 S. Van Ness, Gardena, Calif. 90249 DA 4-4412
Number Street City Zone State Telephone

Date of Birth 1-12-'37 Place of Birth Blue Earth, Minn.
Month Day Year City State

Father's Name in Full: Dr. Thomas E. Havel Mother's Maiden Name: Elizabeth S. Schiltz

Present Address 538 Marguerita, Santa Monica Present Address same

Living? yet Age in Years 59 Religion R. C. Living? Yes Religion R. C.

Nationality American Place of Birth Minn. Nationality American Place of Birth Nebr.

Occupation Doctor Occupation Housewife

Graduate of High School? Montgomery Min. Graduate of High School? Grand Island, Nebr.
Name of High School Name of High School

Mongomery, Minn. Grand Island, Nebr.
Location of High School Location of High School

Graduate of College? Creighton Graduate of College? St. Catherine's School
Name and Location of College Name and Location of College

Omaha, Nebr. Omaha, Nebr.

Name and Address of Business: 2200 Santa Monica Name and Address of Business (if other than housewife)
Blvd., Santa Monica, Calif. same as above

If parents are deceased, give guardian's name _____ (Address)

(City) (State) (Relationship) (Occupation)

Number of Older Brothers none Younger Brothers 3 Older Sisters none Younger Sisters 1

| * Chronological list of all high schools and colleges attended | Location (City and State) | Date Entered (Month & Year) | Date Left | Month & Year of high school and/or college graduation |
|--|---------------------------|-----------------------------|--------------|---|
| <u>St. Monica's Boys' High</u> | <u>Santa Monica, Ca.</u> | <u>9/'51</u> | <u>5/'55</u> | <u>same</u> |
| <u>St. John's Seminary</u> | <u>Camarillo, Calif.</u> | <u>9/'55</u> | <u>5/'63</u> | <u>5/'59</u> |
| | | | | |
| | | | | |

Parish to which you now belong St. Anthony's 1050 W. 163 rd, Gardena, Ca.
Name Address

Pastor's Name Rev. James E. Hansen Does he know you personally? Yes No

What Priest knows you personally? Msgr. Lawrence O'Leary 1531 W. 9th St.

MAR-HAVL 000171

Are there any Priests or Religious in your family Yes No

| Name | Relationship |
|------|--------------|
| | |

List three reliable persons who would supply recommendations for you if so registered:

Dr. Marvin Mack 1212 7th St. Santa Monica, Calif.
 Name Address

Rev. Richard Murray 24410 Calvert St. Woodland Hills, Calif.

Rt. Rev. Msgr. Raymond o'Flaherty 715 California Ave., Santa Monica, Calif.

If you have ever been in any religious order, congregation or seminary, give the following information:

Archdiocese of Los Angeles, 19-63-1969 Join S.M.
 Institution Length of time spent there Reasons for leaving

If you have ever lived for a period of SIX MONTHS OR MORE in any OTHER diocese than the present one, after your 14th birthday, give the following information:

none
 Diocese Your home address there Dates

Have you any debts or obligations? Yes No If so, which?

If registered for Selective Service, give classification: 4-D

If a G. I. inclose your: Serial number, latest rank and branch of the service:

Date and place of induction: Date and place of separation:

Names of camps or bases at which you were stationed:

The names of as many of your chaplains as you can recall:

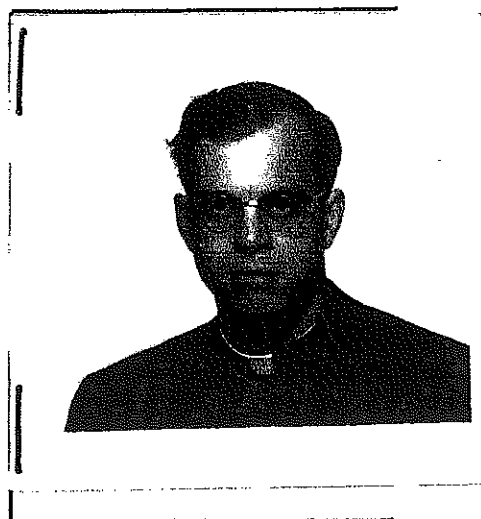

- This application should be accompanied by:
- Letter requesting admission to the Society of Mary, addressed to Reverend Father Provincial, Box 586, Santa Cruz, California.
 - Pastor's Recommendation.
 - Recommendation of local Marianist Superior.
 - Recommendation of the Principal of the school you last attended.
 - Medical Form
 - Parents' Consent Form.
 - Baptism Form.
 - Confirmation Form
 - Copy of Parents' Marriage Certificate (be sure Parish in which marriage took place is listed)
 - Transcript of high school and/or college credits to date.

Date March 1, 1970

Thomas E. Havel
 Signature of Applicant

Signature of Marianist Superior

Signature of Parent

MAR-HAVL 000172



CONGREGATIO DE CULTU DIVINO
ET DISCIPLINA SACRAMENTORUM

Prot. N. 1809/97/S

Romae, die 6 decembris 1997

Societatis Mariae

Taxa pro expensis ab Instituto Religioso solvenda :

Causa dispens. ac dimission.: **THOMAS E. HAVEL**

£.100.000.=.....



Inscriptio Procuratori Generali S.M.

PAGATO
CASSIERE
Congr. per il Culto Divino e
la Disciplina dei Sacramenti
17 DIC. 1997

MAR-HAVL 000173



CONGREGATIO DE CULTU DIVINO
ET DISCIPLINA SACRAMENTORUM

Romae, die 17 Septembris 1997

Prot. N. 1809/97/S

Reverendissime Pater,

die 15 Septembris 1997 huc rite pervenerunt acta processus
administrativi pro dispensatione ab obligationibus sacrae Ordinationis et a votis in favorem
P. i THOMAS E. HAVEL presbyteri istius Instituti.

Eadem acta sub n. 1809/97/S in tabulario Dicasterii persignata sunt.

Quam primum ac iuxta proportionata tempora, de eorundem
pertractatione nuntium habebis.

Quo par est obsequio, me profiteor

In Domino

Reverendissimo Patri

P. ENRIQUE TORRES

Procuratori Generali S.M.

(Via Latina, 22

00179 R O M A)

MAR-HAVL 000174

For your information and info



CONGREGATIO DE CULTU DIVINO ET DISCIPLINA SACRAMENTORUM

PROT. N. 1809/97/S

D.nus THOMAS E. HAVEL, sacerdos, Societatis Mariae,

petiit dispensationem a sacerdotali coelibatu et ab omnibus oneribus sacrae Ordinationi conexas.

SS.mus D. N. Ioannes Paulus, Papa II,

die 6 decembris 1997

habita relatione de casu a Congregatione de Cultu Divino et Disciplina Sacramentorum, precibus annuit iuxta sequentes rationes:

1. Dispensatio vim habet ab ipso momento concessionis.

2. Dispensationis Rescriptum, a competenti Ordinario oratori notificetur et amplectitur inseparabiliter dispensationem a sacerdotali coelibatu et simul amissionem status clericalis. Numquam oratori fas est duo illa elementa seiungere, seu prius accipere et alterum recusare. Si vero orator est religiosus, Rescriptum concedit etiam dispensationem a votis. Idemque insuper secumfert absolutionem a censuris, quatenus opus sit.

3. Notitia concessionis dispensationis adnotetur in libris baptizatorum pa roeciae oratoris.

4. Quod attinet ad celebrationem canonici matrimonii, applicandae sunt normae quae in Codice Iuris Canonici statuuntur. Ordinarius vero curet ut res caute peragantur sine pompa vel exteriore apparatu.

5. Auctoritas ecclesiastica, ad quam spectat Rescriptum oratori notificare, hunc enixe hortetur, ut vitam Populi Dei, ratione congruendi cum nova eius vivendi condicione, participet, aedificationem praestet et ita amantissimum Ecclesiae filium se exhibeat. Simul autem eidem notum faciat ea quae sequuntur:

a) sacerdos dispensatus eo ipso amittit iura statui clericali propria, dignitates et officia ecclesiastica; ceteris obligationibus cum statu clericali conexas non amplius adstringitur;

b) exclusus manet ab exercitio sacri ministerii, iis exceptis de quibus in cann. 976, 986, § 2 ac propterea nequit homiliam habere. Insuper nequit fungi ministerio extraordinario sacrae Communionis distribuendae nec potest officium gerere directivum in ambitu pastoralis;

c) item nullum munus absolvere potest in Seminariis et in Institutis aequiparatis. In aliis Institutis studiorum gradus superioris, qui quocumque modo dependent ab Auctoritate ecclesiastica, munere directivo vel officio docendi fungi nequit;

MAR-HAVL 000175

d) in iisdem vero Institutis studiorum gradus superioris ab Auctoritate ecclesiastica non dependentibus nullam disciplinam proprie theologiam vel cum ipsa intime conexam tradere potest;

e) in Institutis autem studiorum gradus inferioris dependentibus ab Auctoritate ecclesiastica munere directivo vel officio docendi fungi nequit nisi Ordinarius, pro suo prudenti iudicio et remoto scandalo, ad munus docendi quod attinet, aliter decernere aestimaverit. Eadem lege tenetur sacerdos dispensatus in tradenda Religione in Institutis eiusdem generis non dependentibus ab Auctoritate ecclesiastica.

6. Per se presbyter a sacerdotali coelibatu dispensatus et a fortiori matrimonio iunctus, abesse debet a locis in quibus eius antecedens condicio nota est. Ordinarius loci commorationis oratoris tamen, audito quatenus opus erit, Ordinario incardinationis vel Superiore maiori religioso, dispensare poterit ab ista clausula Rescripti, si oratoris praesentia scandalum paritura non praevideatur.

7. Denique ei aliquod opus pietatis vel caritatis imponatur.

8. Notificatio dispensationis fieri potest vel personaliter per notarium aut ecclesiasticum actuarium vel per «epistulas perscriptas» (raccomandata, certificada, enregistrée, registered, einschreiben). Orator unum exemplar restituere debet rite subsignatum ad fidem receptionis et acceptionis eiusdem dispensationis ac simul etiam praeceptorum.

9. Tempore autem opportuno Ordinarius competens breviter ad Congregationem de peracta notificatione referat et, si qua tandem fidelium admiratio adsit, prudenti explicatione provideat.

Contrariis quibuscumque minime obstantibus.

Ex Aedibus Congregationis, die 6 decembris 1997.

CONCORDAT CUM ORIGINALI

quod in Archivo huius

Congregationis asservatur.

die 16 DIC. 1997

Ferrara, Subsec.

(+ Georgius Medina Estévez)
Archiep. Pro-Praefectus

(+ Gerardus Majella Agnelo)
Archiep. Secretarius

Dies notificationis

Jan 21, 1998

J. E. Hauf

Subsignatio Oratoris in signum acceptionis

Rer. John Rumi, SM

Subsignatio Ordinarii

Maria Duce!

SOCIETY OF MARY

FORMULA OF TEMPORARY PROFESSION

For the glory of the Most Holy Trinity and
the honor of Mary, for my sanctification
and the salvation of men, I

Thomas Havel

promise to God and vow to observe during
one year chastity, poverty and obedience,
conformably to the Constitutions of the
Society of Mary.

Done at: Danville

Signed: Thomas E. Havel S.M.

13 August 1978
(Day) (Month) (Year)

HAVEL, Thomas

Maria Duce!

SOCIETY OF MARY

FORMULA OF TEMPORARY PROFESSION

For the glory of the Most Holy Trinity and
the honor of Mary, for my sanctification
and the salvation of men, I

Thomas E. Havel.
promise to God and vow to observe during
one year chastity, poverty and obedience,
conformably to the Constitutions of the
Society of Mary.

Done at: Cupertino

Signed: Thomas E Havel, S.M.

4 12 '77
(Day) (Month) (Year)

HAVEL, Thomas

Maria Duce!

SOCIETY OF MARY

FORMULA OF TEMPORARY PROFESSION

For the glory of the Most Holy Trinity and
the honor of Mary, for my sanctification
and the salvation of men, I

Thomas Havel
promise to God and vow to observe during
one year chastity, poverty and obedience,
conformably to the Constitutions of the
Society of Mary.

Done at: Santa Barbara

Signed: Thomas E. Havel, S.M.

13 June 1976
(Day) (Month) (Year)

HAVEL, Thomas

Maria Duce!

SOCIETY OF MARY

FORMULA OF TEMPORARY PROFESSION.

For the glory of the Most Holy Trinity and
the honor of Mary, for my sanctification
and the salvation of men, I

Thomas Havel
promise to God and vow to observe during
one year chastity, poverty and obedience,
conformably to the Constitutions of the
Society of Mary.

Done at: Honolulu, Hawaii

Signed: Thomas E. Havel, Jr.

7th June 1975
(Day) (Month) (Year)

Maria Duce!

SOCIETY OF MARY

FORMULA OF THE TEMPORARY PROFESSION

For the glory of the Most Holy Trinity, the honor of Mary, the salvation of all men and to follow Christ more closely, I,

Thomas Havel

promise to God and vow to observe during one year Chastity, Poverty and Obedience conformably to the Constitutions of the Society of Mary.

Done at Bethesda, Md.

Signed: Thomas Havel

23 June 1974
(Day) (Month) (Year)

Maria Duce!

SOCIETY OF MARY

FORMULA OF THE TEMPORARY PROFESSION

For the glory of the Most Holy Trinity, the honor of Mary, the salvation of all men and to follow Christ more closely, I,

Thomas Havel

promise to God and vow to observe during one year Chastity, Poverty and Obedience conformably to the Constitutions of the Society of Mary.

Done at Baltimore --

Signed: Thomas C. Havel, S.M.

23rd June 1973
(Day) (Month) (Year)

Maria Duce!

SOCIETY OF MARY

FORMULA OF THE TEMPORARY PROFESSION

For the glory of the Most Holy Trinity, the honor of Mary, the salvation of all men and to follow Christ more closely, I,

Thomas Havel

promise to God and vow to observe during one year Chastity, Poverty and Obedience conformably to the Constitutions of the Society of Mary.

Done at San Damiano - - -

Signed: Thomas Havel

| | | |
|-----------|---------------|-------------|
| <u>13</u> | <u>August</u> | <u>1972</u> |
| (Day) | (Month) | (Year) |

J.M.J.

In baptism I was buried with Christ, so that I might live His new life in the power of His Resurrection. This baptism-consecration made me another Christ, Son of Mary. Today, I want to renew this consecration.

I consecrate myself now in the Society of Mary, in order to begin my preparation for profession as a Marianist. I consecrate myself in the Society of Mary in order:

-- to strive together with my fellow Marianists to attain the perfection of charity,

-- to follow Christ more closely through a life conformable to his, a life which was poor, chaste and obedient,

-- to confide myself to Mary, so that under her care, she might render me more conformable to her Son, Jesus Christ,

-- to form an alliance with Mary, the Mother of the Savior and the woman associated in the mystery of salvation, so as to assist her in her mission in the Church of restoring supernatural life to men,

-- to live together with my fellow Marianists in community, so as to praise God in prayer with them, to aid them in attaining a closer union with the Risen Christ, and with them to spread the Kingdom of God to all men by multiplying Christians,

-- and finally, to dedicate my priestly ministry and service to my fellow Marianists and their apostolate.

Through this consecration today, with the aid of the Holy Spirit and our Blessed Mother, I am confident I can live my life in the power of the Risen Christ to the greater glory of the Father and to the greater service of my fellow Marianists and all mankind.

Thomas Havel
(signature)

Feb. 3, 1971
(date)

MAR-HAVL 000184

Record of Test Data

| NAME OF TEST | GRADE | DATE GIVEN | TEST SCORE |
|--------------|----------|------------|-----------------------------|
| Cal. Reading | Advanced | 12/18/52 | Gr. Pl. 13.7 \$116 95 |

Record of Participation in Extra-Curricular Activities

| ACTIVITY | DATE |
|----------|------|
| | |
| | |

Transferred to _____

College Grade Received _____

Sherry Schriber 2/27/50

**SAINT MONICA'S HIGH SCHOOL
SANTA MONICA, CALIFORNIA**

Student's full name Havel, Thomas E. Jr.

Student's address 240 18th. Street
 Santa Monica, California

Date of student's birth October 12 1937
MONTH DAY YEAR

Date student entered this school September 14 1951
MONTH DAY YEAR

Student graduated June 19 1955
MONTH DAY YEAR

Number in graduating class 65

Approximate rank in graduating class 3

Student withdrew without graduating _____
MONTH DAY YEAR

Father or Guardian Dr. T. E. Havel Saint Monica's

School Year

High School Attended

19 51 - 19 52

1st Sem. St. Monica's
2d Sem. Same

| NAME OF SUBJECT | SEM. MARKS | | CREDITS | | 1st Sem. | 2d Sem. |
|-----------------|------------|----|---------|---------------|----------|---------|
| | 1st | 2d | | | | |
| Religion | A | A | 1 | Days Absent | 1 | 0 |
| English | B | B | 1 | Times Tardy | 0 | |
| Algebra I | B | B | 1 | Cleanliness | A | A |
| History | A | A | 1 | Obs. of Rules | | |
| Latin | B | B | 1 | Courtesy | | |
| Hygiene | A | B | 1 | Office Work | | |
| P.E. | A | A | 1 | | | |
| Topics | | C | 1 | | | |

19 52 - 19 53

1st Sem. St. Monica's
2d Sem. Same

| | | | | | | |
|------------|---|---|---|---------------|---|---|
| Religion | A | A | 1 | Days Absent | 0 | 2 |
| English | B | B | 1 | Times Tardy | | |
| Algebra II | B | A | 1 | Cleanliness | A | B |
| History II | B | B | 1 | Obs. of Rules | | |
| Latin II | B | B | 1 | Courtesy | | |
| P.E. | B | A | 1 | Office Work | | |

19 53 - 19 54

1st Sem. St. Monica's
2d Sem. Same

| | | | | | | |
|-----------|---|---|---|---------------|---|---|
| Religion | A | A | 1 | Days Absent | 3 | 1 |
| English | B | B | 1 | Times Tardy | 2 | 5 |
| Latin III | C | B | 1 | Cleanliness | A | A |
| History | A | A | 1 | Obs. of Rules | | |
| Chemistry | A | A | 1 | Courtesy | | |
| Geometry | A | B | 1 | Office Work | | |

19 54 - 19 55

1st Sem. St. Monica's Boys'
2d Sem. Same

| | | | | | | |
|------------------------|---|---|---|---------------|---|---|
| Religion | A | A | 1 | Days Absent | 0 | 0 |
| English | B | B | 1 | Times Tardy | 0 | 2 |
| Biology | A | A | 1 | Cleanliness | A | A |
| Trig. & Solid Geometry | A | A | 1 | Obs. of Rules | | |
| Physics | A | B | 1 | Courtesy | | |
| Civics & Sociology | A | A | 1 | Office Work | | |

AWARDS:
Pastor's award for outstanding student in Religion

Final Marks: A-Superior, B-Recommended, C-Average, D-Diminishing, F-Failure.

Cleanliness Medal

The following areas are proposed for study under the direction of various Marianists:

1. History of Religious Life (Father Malley)
2. Study of the Vatican Documents on Religious Life*(Father Tutas) (Two Parts)
3. Theology of religious life, study of the Constitutions of the Society of Mary
3 Vow/JSJ
a. Preliminary Chapter of the 1967 Constitutions (Father Stefanelli)
b. Vow of Stability and the role of the Blessed Virgin Mary (Father Clemens)
c. Other Chapters of the 1967 Constitutions (Father Rielly, Father Tutas) (Two Parts)
4. The life of Father Chaminade, the history of the Society of Mary (Father Hughes, Father Bach) (Two Parts)
5. The apostolate in the Society of Mary
a. Education (Brother Richter)
b. Specialized Works (Father Stefanelli)
6. The priesthood in the Society of Mary (Father Tutas)

| | |
|---------------------------------|---|
| June, 1970 (2-3 weeks) | 2 - Part I 4 - Part I 3a (June 8-12) |
| August, 1970 (2-3 weeks) | Marianist retreat: Prayer (Father Bolin) (August 9-14) 1 3b |
| December, 1970 (3 weeks) | 3c - Part I |
| January, 1971 (2 weeks) | 3c - Part II |
| June-August, 1971 (3 months) | 1 2 - Part II 5a 5b 6 Systematic Study of the Marianist documents (Father Stefanelli) Marianist Retreat Marianist Studies Workshop (tentative) |

* Dogmatic Constitution on the Church, Chapter VI: Religious Decree on the Appropriate Renewal of the Religious Life

Proposed novitiate program for Father Thomas Havel

Evidently, Father Thomas Havel has achieved a human and Christian maturity superior to other candidates. The program is designed, therefore, to emphasize an intensified growth in the religious life according to the Constitutions of the Society of Mary.

Father Havel is presently pursuing a course of studies in medicine with an eventual specialization in psychiatry.

Our proposal is that Father Havel follow a series of intensive workshops from June, 1970 through the summer of 1971, at the conclusion of which he could be approved to profess vows as a member of the Society of Mary.

Throughout the years of his professional studies, Father Havel could participate in further workshops to deepen his knowledge and aid his practice of the religious life in the Society of Mary.

The proposed workshops would be characterized as periods of prayer and guided study and research.

I would be responsible for the overall direction of the program and for the personal external direction. Father would be encouraged to work regularly with a Marianist priest for confession and spiritual direction.

It is understood that Father would continue to reside in our Gardena community while attending classes at Loyola University, coming to Cupertino for the various workshops. Father's complete and significant participation in the total life of the Gardena community is an important element in this program.

NAME Havel Thomas Rev. of the Diocese of _____
 (Family Name) (Christian Name)

GENERAL INFORMATION

Father's Name Thomas E. Havel Address 538 Marguerita, Santa Monica
 Mother's Name Elizabeth S. Schiltz Address 538 Marguerita, Santa Monica
 Guardians's Name _____ Address _____

Entered Postulate at _____ Date of Entrance _____
 Entered Novitiate at _____ Date of Entrance 2-3-71

| Temporary Vows | | |
|----------------|---------|--------|
| Place | Date | Term |
| Danville | 8-13-72 | 1 yr |
| Baltimore | 6-23-73 | 1 yr |
| Bethesda | 6-23-74 | 1 yr |
| Honolulu | 6-7-75 | 1 yr |
| Santa Barbara | 6/13/76 | 1 year |
| | | |
| | | |
| | | |
| | | |

Province of the Pacific

Birth Place Blue Earth, Minnesota Date 10-12-3
 (City) (State)
 Baptism Ss. Peter & Paul Church
 Place Blue Earth, Minnesota Date 10-27-3
 (City) (State)
 Confirmation _____ Date _____
 Place _____ (City) (State)
 Perpetual Vows _____ Date 8/10/80
 Place _____ (City) (State)
 Ordination St. Vibiana Cathedral
 Place Los Angeles, California Date 5-3-63
 (City) (State)
 Death _____ Date _____
 Place _____ (City) (State)
 Withdrawal _____ T P Date _____
 Place _____ (City) (Establishment)

NAME, Havel, Thomas

8/1969 - 1972 in residence at Serra (Loyola, Novitiate)
 Aug 13, 1972 first vows Danville
 (May 10, 1972 excommunicated)
 Aug. 10, 1980 final vows
 Edward A. Hurshaw 293-5959

Aug 10, 1972 → Nov '73
 15 min

76-George Brown

MAR-HAVL 000189

NAME Havel Thomas Rev. of the Diocese of _____
 (Family Name) (Christian Name)

GENERAL INFORMATION

Father's Name Thomas E. Havel Address 538 Marguerita, Santa Monica
 Mother's Name Elizabeth S. Schiltz Address 538 Marguerita, Santa Monica
 Guardians's Name _____ Address _____

Entered Postulate at _____ Date of Entrance _____
 Entered Novitiate at _____ Date of Entrance 2-3-71

| Temporary Vows | | |
|----------------|---------|--------|
| Place | Date | Term |
| Danville | 8-13-72 | 1 yr |
| Baltimore | 6-23-73 | 1 yr |
| Bethesda | 6-23-74 | 1 yr |
| Honolulu | 6-7-75 | 1 yr |
| Santa Barbara | 6/13/76 | 1 year |
| | | |
| | | |
| | | |
| | | |

Birth Place Blue Earth, Minnesota Date 10-12-37
 (City) (State)
 Baptism Ss. Peter & Paul Church
 Place Blue Earth, Minnesota Date 10-27-37
 (City) (State)
 Confirmation Place _____ Date _____
 (City) (State)
 Perpetual Vows Place _____ Date _____
 (City) (State)
 Ordination St. Vibiana Cathedral
 Place Los Angeles, California Date 5-3-63
 (City) (State)
 Death Place _____ Date _____
 (City) (State)

Province of the Pacific

Withdrawal Place Los Altos CA T (P) Date 1/21/98
 (City) (Establishment)
& from priesthood

NAME, Havel, Thomas

NAME

Province of the Pacific

| PLACES AND EMPLOYMENTS | | | | Academic Degrees | | | |
|------------------------|---------------------|-----------------|-------------|------------------|---------|----------------|-------|
| Date | Place | Employment | Director | Degree | Subject | Conferred Date | Place |
| 9-1-72 | Washington DC | Student | | M. D. | | | |
| 8-75 | Gardena | Internship | Bro. Haster | | | | |
| 8-76 | " | ACTING DIRECTOR | | | | | |
| 8-79 | Cupertino Aspirancy | Student | Fr. DeLong | | | | |
| 8-80 | Palo Alto | | | | | | |
| 8-81 | Saratoga | | | | | | |
| 8-84 | Cupertino-MFC | in residence | Fr. Clemens | | | | |
| 8-85 | " " | " | Fr. Hughes | | | | |
| 4/88 | Cupertino | | | | | | |
| 5/89 | Los Altos | | | | | | |
| | | | | | | | |
| | | | | | | | |
| | | | | | | | |
| | | | | | | | |
| | | | | | | | |
| | | | | | | | |
| | | | | | | | |
| | | | | | | | |
| | | | | | | | |
| | | | | | | | |
| | | | | | | | |

MAR-HAVL 000190

LOYOLA UNIVERSITY OF LOS ANGELES - MARYMOUNT COLLEGE
OFFICE OF THE REGISTRAR

Date: 3/27/70
Name: Thomas E. Jr.
Student's Address: 4830 Van Ness
Tampa, Calif.

REQUEST FOR TRANSCRIPT

Currently enrolled? Yes No
If no, date of last attendance: _____
Cost per copy: \$1.00 Total: \$ _____
Number of copies to be sent: _____
Hold for final grades? Yes No
Treasurer's Approval: _____
Transcript Issued: _____

Print Plainly the name and address of the institution you wish to receive this transcript.
THIS FORM WILL BE USED FOR MAILING.

Very Rev. Bernard Clements
Majorist Province of Residence
P.O. Box 937
Cupertino, Calif 95014

MAR 4 1970

Transcripts will be sent out in turn as requests are received. Requests must be made at least one week before transcript is needed.

LOYOLA UNIVERSITY OF LOS ANGELES - MARYMOUNT COLLEGE
OFFICE OF THE REGISTRAR

Date 2/27/70
Name Havel, Thomas E, JR
Student's Address 14830 S. VAN NESS
GARDENA, CALIF.

Print Plainly, the name and address of the institution you wish to receive this transcript.
THIS FORM WILL BE USED FOR MAILING.

Very Rev Bertrand Clemens
MARINIST Provincial Residence
P.O Box 937
Cupertino, Calif 95014

Transcripts will be sent out in turn as requests are received. Requests must be made at least one week before transcript is needed.

REQUEST FOR TRANSCRIPT

Currently enrolled? Yes No

If no, date of last attendance

Cost per copy: \$1.00 Paid: \$ M.C.

Number of copies to be sent 1

Hold for final grades? Yes No

Treasurer's Approval:

Transcript issued:

MAR-HAVL 000192

LOYOLA UNIVERSITY OF LOS ANGELES
LOS ANGELES, CALIFORNIA

Office of the Registrar

TRANSCRIPT OF CREDITS

| | |
|---|---|
| NAME <u>HAVEL, THOMAS EARL JR.</u> | ENTERED <u>6-21-57</u> WITHDREW _____ |
| LOCAL ADDRESS <u>240 -18th St., Santa Monica, Calif</u> | COLLEGE <u>A & S</u> MAJOR <u>Biology</u> |
| HOME ADDRESS <u>Same as above</u> | GRADUATED _____ DEGREE _____ |
| PARENT OR GUARDIAN <u>Dr. & Mrs. Thomas Havel</u> | DATE OF BIRTH: <u>10-12-37</u> |

| HIGH SCHOOL UNITS | DEPT. | NO. | TITLE | S.CR. | GR. | S.P. | DEPT. | NO. | TITLE | S.CR. | GR. | S. |
|-------------------|------------|-----|--------------------------------------|-------|-----|------|-------|-----|-------|-------|-----|----|
| St. Monica's H.S. | | | SUMMER, 1957 | | | | | | | | | |
| | Ec. | 51 | Prin. of Economics | 3 | B | 6 | | | | | | |
| | So. | 128 | Amer. Cath. Family | 3 | B | 6 | | | | | | |
| GRADUATED | | | Accepted on Transfer from St. John's | | | | | | | | | |
| ENGLISH | CHEM. | | College- 9/69 | | | | | | | | | |
| ALGEBRA | PHYSICS | | Transfer Credit | | | | | | | | | |
| GEOM. | OTHER SCI. | | Courses Attempted 98 | | | | | | | | | |
| TRIG. | | | Courses Completed 98 | | | | | | | | | |
| HISTORY | | | Grade Points 267.5 | | | | | | | | | |
| CIVICS | LANGUAGE | | Average 2.73 | | | | | | | | | |
| ELECTIVES | | | Loyola Conversion | | | | | | | | | |
| | | | Courses Attempted 2 | | | | | | | | | |
| ACCEPTANCE | | | Courses Completed 2 | | | | | | | | | |
| DEFICIENCIES | | | Grade points 6.0 | | | | | | | | | |
| | | | Average 3.00 | | | | | | | | | |

| DEPT. | COURSE NO. | COURSE TITLE | COURSE VALUE | GRADE | GRADE POINTS |
|-------|------------|-------------------------|--------------|-------|--------------|
| | | FALL 1969 | | | |
| BL | 1 | GEN BIOLOGY I | 1.00 | A | 4.0 |
| CH | 1 | GEN CHEMISTRY I | 1.00 | B | 3.0 |
| MA | 21 | MATH ANAL LIB ARTS I | 1.00 | A- | 3.7 |
| | | MAJOR BL GPA 3.58 TOTAL | 3.00 | | 10.7 |

TRANSCRIPTS SENT
St. John's Col. 8-26-57

Our Lady Queen of the Angels 8-26-57

GRADING SYSTEM:
A OUTSTANDING W OFFICIAL WITHDRAWAL
B SUPERIOR FW WITHDREW FAILING
C AVERAGE FA FAILURE FOR
D PASSING EXCESSIVE ABSENCES
F FAILURE
I WORK INCOMPLETE

MAR-HAVL 000193

| | |
|--------------|--|
| TEST RESULTS | I CERTIFY THAT THE ABOVE INFORMATION IS CORRECT AND THAT THE STUDENT IS ENTITLED TO HONORABLE DISMISSAL UNLESS OTHERWISE INDICATED |
| | MAR 4 1970 <i>C. J. P. mensel AB</i> |

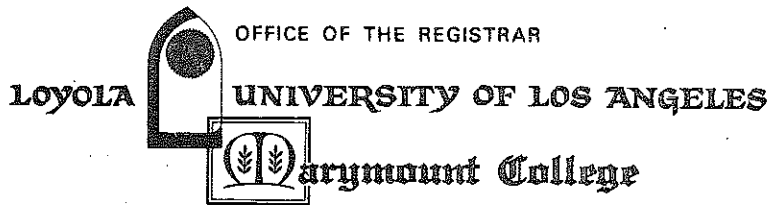

7101 WEST 80TH STREET · LOS ANGELES, CALIF. 90045

CREDIT

Effective September 1967, the undergraduate and graduate curriculum of the University were converted to a course system instead of two semesters. The academic year consists of three eleven week terms. Courses meet four times per week for fifty minute periods. Natural Science and Engineering courses have, in addition to the four lecture periods, laboratory periods for which no separate credit is given. All courses have the same weight for graduation and for computing grade points.

Some courses listed on this transcript will show no course value. They are partial courses and course value will not be earned until the total parts required are completed.

COURSE NUMBERING AND CREDIT

| Courses Numbered | Classification | Equivalent to |
|------------------|-------------------------------------|------------------------------|
| 1 to 99 | Lower division & Physics & Engr. | 4 Qtr. Hrs. or 2.7 Sem. Hrs. |
| 100 to 199 | Upper division except Phys. & Engr. | 5 Qtr. Hrs. or 3.3 Sem. Hrs. |
| 200 to 299 | Upper Division | 5 Qtr. Hrs. or 3.3 Sem. Hrs. |
| 300 to 399 | Professional & Credential | 4 Qtr. Hrs. or 3.0 Sem. Hrs. |
| 400 to 499 | Graduate Only | 4 Qtr. Hrs. or 3.0 Sem. Hrs. |

GRADE POINTS

| | | |
|----------|----------|--|
| A = 4.0 | C+ = 2.3 | S = S is the symbol used for work satisfactorily completed on a passed-fail course. Such courses count toward the student's graduation requirements. |
| A- = 3.7 | C = 2.0 | |
| B+ = 3.3 | C- = 1.7 | |
| B = 3.0 | D = 1.0 | |
| B- = 2.7 | F = 0.0 | |
| | | U = U is the symbol used for work unsatisfactorily completed on a pass-fail course. |

Neither passed nor failed courses affect the student's grade point average.

BRANCHES AND AFFILIATED SCHOOLS

The School of Law; The college of the Queen of Peace, Santa Barbara, California; and St. Vincent's College of Nursing continue to remain on the semester system.

MAR-HAVL 000194

| | |
|--|---|
| NAME HAVEL Thomas Earl | Date of Birth 10/12/37 |
| Address 240 18th St Santa Monica Calif | Date of Admission 9/19/55 |
| Secondary School St Monica HS Santa Monica Calif 6/1955 | Entrance Credits: Relig cr Eng 4 Lat 3 Alg 2 Solid Geom 1/2 |
| Date Graduated: _____ | Trig 1/2 Eu Hist 2 US Hist 1 Civics 1/2 Sociol 1/2 Chem 1 |
| Statement on Admission: Special standing | Physics 1 Biol 1 Pl Geom 1 Typing cr Phys Educ cr Hygiene cr |

| YEAR | COURSE NUMBER | NAME OF COURSE | 1st SEM. | | | 2nd SEM. | | | COMMENT |
|-------|---------------|---|----------|-----|------|----------|-----|------|---------|
| | | | GR. | UN. | G.P. | GR. | UN. | G.P. | |
| 1955 | Re 10ab | Apologetics and Christian Doctrine | B | 2 | 4 | A | 2 | 6 | |
| 1956 | En 11ab | College Composition | C | 3 | 3 | B | 3 | 6 | |
| | Lt 1 | Beginning Latin | B | 6 | 12 | | | | |
| | Lt 2 | Latin Readings | | | | C | 6 | 6 | |
| | Gk 14ab | Beginning Greek | A | 3 | 9 | B | 3 | 6 | |
| | Ma 10ab | College Algebra | B | 3 | 6 | B | 3 | 6 | |
| | Mu 10cd | Gregorian and Modern Music | C | 1 | 1 | C | 1 | 1 | |
| SS | | | | | | | | | |
| 1956 | Lt 3S | Grammar and Composition | B | 2 | 4 | | | | |
| 1956 | Re 20ab | Moral Guidance | A | 2 | 6 | A | 2 | 6 | |
| 1957 | En 22ab | English and American Literature | B | 3 | 6 | B | 3 | 6 | |
| | Lt 12 | Cicero De Senectute De Amicitia | A | 3 | 9 | | | | |
| | Lt 21 | Medieval Latin | | | | B | 3 | 6 | |
| | Gk 24 | Intermediate Greek | C | 3 | 3 | | | | |
| | Gk 25 | Xenophon Patristic Greek | | | | C | 3 | 3 | |
| | Hs 22ab | United States History and Government | B | 3 | 6 | B | 3 | 6 | |
| | Lt 13a | Latin Composition | B | 1 | 2 | | | | |
| | Lt 25 | Ecclesiastical Latin | | | | C | 1 | 1 | |
| | Sc 20b | Survey of Physical Science | | | | B | 3 | 6 | |
| | Mu 10ab | Gregorian and Modern Music | B | 1 | 2 | B | 1 | 2 | |
| | | <u>LOYOLA UNIVERSITY OF LOS ANGELES, California</u> | | | | | | | |
| 3S-57 | Ec. 51 | Prin. of Economics | B | 3 | 6 | | | | |
| | So.128 | Amer. Cath. Family | B | 3 | 6 | | | | |

A.A. Degree conferred: _____ American Institutions requirement satisfied: Hs 22ab
 7/10/57
 BJMc

591 HAVEL, Thomas Earl

ST. JOHN'S COLLEGE
UPPER DIVISION
Camarillo, Calif.

HAVEL, Thomas Earl

Second Side

| YEAR | COURSE NUMBER | NAME OF COURSE | 1st SEM. | | | 2nd SEM. | | | COMMENT |
|--|--|---|-----------------|-----|------|-----------------|-----|-----------|------------------------------|
| | | | GR. | UN. | G.P. | GR. | UN. | G.P. | |
| <u>ST. JOHN'S COLLEGE, Camarillo, Calif.</u> | | | <u>18 weeks</u> | | | <u>18 weeks</u> | | | |
| 57-58 | Biol 30ab | Biology | B | 3 | 6 | A | 3 | 9 | Tests: Musc -c |
| | Educ 00 | Scholastic Orientation | C | 0 | - | | | | |
| | Hist 13lab | History, 1-590 A.D. The imperialist world | C | 2 | 2 | B | 2 | 4 | |
| | Musc 13la | Gregorian Chant. Intermediate Choral, A | B | 1 | 2 | | | | |
| | Musc 150c | Polyphonic Choir, B | A | 1 | 3 | | | | |
| | Phil 135 | Logic | C | 5 | 5 | | | | |
| | Phil 136 | Cosmology | | | | C | 4 | 4 | |
| | Phil 137 | Epistemology | B | 3 | 6 | | | | |
| | Phil 138 | Advanced Psychology | | | | B | 4 | 8 | |
| | Reln 13lab | Bible: Reading Introduction, A | B | 1 | 2 | C | 1 | 1 | |
| | Socy 00 | Social Ethics | | | | B | 0 | - | |
| | Span 50ab | Elementary Spanish, A | C | 3 | 3 | C | 3 | 3 | |
| | Spch 130ab | Speech Delivery and Composition, Part I | C | 1 | 1 | C | 1 | 1 | |
| 58-59 | Educ 146 | Principles of Education | | | | B | 3 | 6 | Tests: Econ c Spch c |
| | Engl 103 | Shakespeare | B | 3 | 6 | | | | |
| | Hist 13lcd | History, 590-1073 A.D. The feudal world | C | 2 | 2 | C | 2 | 2 | |
| | Musc 13lcd | Gregorian Chant. Intermediate Choral, B | B | 1 | 2 | B | 1 | 2 | |
| | Phil 140ab | Metaphysics and Ethics | C | 4 | 4 | B | 4 | 8 | |
| | Phil 148ab | History of Philosophy | B | 3 | 6 | B | 3 | 6 | |
| | Reln 147 | Bible: General Introduction | C | 3 | 3 | | | | |
| | Reln 13lcd | Bible: Reading Introduction, B | C | 1 | 1 | C | 1 | 1 | |
| | Span 5lab | Intermediate Spanish | C | 3 | 3 | C | 3 | 3 | |
| Spch 140 b | Speech Delivery and Composition, Part II | | | | C | 1 | 1 | | |
| A.B. Degree granted May 30, 1959 | | | | | | | | | |
| COLLEGE TOTALS | | | | 155 | 268 | | | GPA | 1.73 |
| | | | | 155 | 423 | | | GPA: 2.73 | (3 pt scale) (4 pt scale) |

Comprehensive Examination _____ Total Gr. Pts. _____ Total Sem. Crs. _____ Class Rank _____

Degree: _____ Date: _____

American Institutions requirement satisfied: _____

ST. JOHN'S COLLEGE, Camarillo, California
March 2, 1970.

Albert H. Lee, C.M.

(Rev.) Albert H. Lee, C.M. Dean and Registrar

ST. JOHN'S SEMINARY, CAMARILLO, CALIFORNIA

Name HAVEL, Thomas Earl Date of Birth October 12, 1937 Degree A.B.: St. John's College,
 Home Address _____ Parish _____ May 30, 1959
 Secondary School St. Monica HS., Credits: _____
~~Secondary School~~ Santa Monica, Calif.
 Date Grad. June, 1955
 Average _____

| TESTS DATE SCORE | 1 | 2 | 3 | ADMISSION: September 12, 1959 | | | | | | |
|------------------------|------------|-------------------------------------|--|----------------------------------|-----------|------|----------|-------|------|---------|
| | YEAR | DEPARTMENT & NUMBER | NAME OF COURSE | 1ST SEM. | | | 2ND SEM. | | | COMMENT |
| | | | | GR. | UN. | G.P. | GR. | UN. | G.P. | |
| | | | ST. JOHN'S COLLEGE, San Fernando, Calif. | - | 1955/1957 | | | | | |
| | | | LOYOLA UNIVERSITY, Los Angeles, Calif. | - | SS-1957 | | | | | |
| | | | ST. JOHN'S COLLEGE, Camarillo, Calif. | - | 1957/1959 | | | | | |
| | | | ST. JOHN'S SEMINARY, Camarillo, Calif. | 18 | weeks | | 18 | weeks | | |
| 59-60 | Art 150ab | Art Survey, A | C | 1 | 2 | B | 1 | 3 | | |
| | Bibl 212ab | Special Introduction, Exegesis, A | C | 3 | 6 | C | 3 | 6 | | |
| | Econ 150cd | Economics Survey, B | C | 1 | 2 | C | 1 | 2 | | |
| | Educ 210ab | Catechetics | B | 1 | 3 | B | 1 | 3 | | |
| | Educ 250ab | Practice Teaching | B | 1 | 3 | B | 1 | 3 | | |
| | Hist 212ab | Church History, 1073-1517 | B | 2 | 6 | B | 2 | 6 | | |
| | Law 210ab | Canon Law, cc. 1-214 | C | 1 | 2 | B | 1 | 3 | | |
| | Litt 212ab | Patrology, A | B | 2 | 6 | B | 2 | 6 | | |
| | Musc 213ab | Gregorian Chant, Advanced Choral, A | B | 1 | 3 | B | 1 | 3 | | |
| | Span 214gh | Pastoral Spanish, D | D | 1 | 1 | D | 1 | 1 | | |
| | Theo 210ab | Fundamental Theology | C | 5 | 10 | C | 5 | 10 | | |
| | Theo 218ab | Fundamental Moral Theology | B | 5 | 15 | A | 5 | 20 | | |
| 60-61 | Art 150c | Art Survey, B | B | 1 | 3 | | | | | |
| | Bibl 214 | Critical Studies | B | 1 | 3 | A | 1 | 4 | | |
| | Bibl 221ab | Special Introduction, Exegesis, B | C | 3 | 6 | A | 3 | 12 | | |
| | Econ 150ab | Economics Survey, A | C | 1 | 2 | C | 1 | 2 | | |
| | Hist 221ab | Church History, 1517-1789 | B | 2 | 6 | C | 2 | 4 | | |
| | Law 232ab | Canon Law, cc. 1552-2414 | B | 2 | 6 | B | 2 | 6 | | |
| | Litg 227 | General Liturgy | B | 2 | 6 | | | | | |
| | Litt 221ab | Patrology, B | C | 2 | 4 | B | 2 | 6 | | |
| | Musc 213cd | Gregorian Chant, Advanced Choral, B | B | 1 | 3 | B | 1 | 3 | | |
| | Span 214ab | Elementary Pastoral Spanish | C | 1 | 2 | C | 1 | 2 | | |
| | Spch 220ab | Sermon Procedures, A | C | 1 | 2 | C | 1 | 2 | | |
| | Theo 223cd | Special Dogmatic Theology, B | C | 5 | 10 | C | 5 | 10 | | |
| | Theo 232cd | Special Moral Theology, B | B | 4 | 12 | A | 4 | 16 | | |

468 HAVEL, Thomas Earl

Charles E. Miller, C.M.
Registrar

February 27, 1970
Date

MAR-HAVL 000197

HAVEL, Thomas Earl

| YEAR | DEPARTMENT & NUMBER | NAME OF COURSE | 1ST SEM. | | | 2ND SEM. | | | COMMENT |
|---------------------------------|---------------------|--|----------|-----|------|----------|-----|------|----------|
| | | | GR. | UN. | G.P. | GR. | UN. | G.P. | |
| | | ST. JOHN'S SEMINARY, Camarillo, Calif. | 18 weeks | | | 18 weeks | | | |
| 61-62 | Bibl 243ab | Special Introduction, Exegesis, D | B | 2 | 6 | A | 2 | 8 | |
| | Hist 230ab | Church History, 1789-1950 | B | 2 | 6 | B | 2 | 6 | |
| | Law 223ab | Canon Law, cc. 215-1551 | B | 2 | 6 | B | 2 | 6 | |
| | Litg 237 | The Divine Office | | | | A | 2 | 8 | |
| | Musc 213ef | Gregorian Chant, Advanced Choral, C | A | 1 | 4 | A | 1 | 4 | |
| | Span 241cd | Advanced Pastoral Spanish | C | 1 | 2 | C | 1 | 2 | |
| | Spch 230ab | Sermon Procedures, B | C | 1 | 2 | C | 1 | 2 | |
| | Theo 223ab | Special Dogmatic Theology, A | B | 5 | 15 | C | 5 | 10 | |
| | Theo 232ab | Special Moral Theology, A | B | 4 | 12 | B | 4 | 12 | |
| | Theo 237 | Ascetical Theology | B | 2 | 6 | | | | |
| | Theo 238 | Mystical Theology | | | | C | 2 | 4 | |
| 62-63 | Bibl 234ab | Special Introduction, Exegesis, C | A | 2 | 8 | C | 2 | 4 | |
| | Litg 240ab | Sacramental Liturgy | B | 2 | 6 | C | 2 | 4 | |
| | Musc 150ab | Polyphonic Choir, A | A | 1 | 4 | B | 1 | 3 | |
| | Musc 240ab | Ministerial Chant | B | 1 | 3 | B | 1 | 3 | |
| | Span 241ef | Advanced Pastoral Spanish | D | 1 | 1 | C | 1 | 2 | |
| | Spch 240ab | Readings, Homiletics, Special Sermons | C | 1 | 2 | C | 1 | 2 | |
| | Theo 240ab | De Sacramentis, A | B | 5 | 15 | B | 5 | 15 | |
| | Theo 248ab | De Sacramentis, B | B | 5 | 15 | B | 5 | 15 | |
| | Theo 249 | Pastoral Theology | | | | C | 1 | 2 | |
| TOTALS | | | | 176 | 482 | | | | GPA 2.74 |
| Honorable Dismissal May 1, 1963 | | | | | | | | | |

Comprehensive Examination
Major Department

Total Gr. Pts.
Degree Conferred

Total Sem. Crs.
Honors

Class Rank

Charles E. Miller, Chm
Registrar

February 27, 1970
Date

MAR-HAVL 000198

CREDITS AND GRADES

Credits earned are expressed in terms of units or semester hours. There are two semesters per year, each of eighteen weeks. Grade points are to be assigned as follows: grade A, four points for each unit; B, three points for each unit; C, two points for each unit; D, one point for each unit; E and F, no points.

Examinations are held in every course at the end of each semester. Special examinations or tests may be held at any time at the discretion of the professors. Grade are reported according to the following scale:

| | | |
|---------|-------------|------------------------------|
| A..... | 93-100..... | Outstanding |
| B..... | 85-92..... | Good |
| C..... | 77-84..... | Average or basic achievement |
| D..... | 70-76..... | Below average but passing |
| E..... | | Condition * |
| F..... | | Failure |
| WP..... | | Withdrew passing |

* Second examination required for passing grade.

TIMOTHEUS MANNING

Dei atque sedis Apostolicae Gratia

Archiepiscopus Angelorum in California

Universis et singulis literas praesentes inspecturis notum facimus quod Anno a Nativitate Domini 1963

die vero 1^a mensis Maii Ordines Celebrantes in Cathedrali Sanctae Vibianae

dilectum nobis in Christo REVERENDUM THOMAS E. HAVEL

examinatum et approbatum, atque in moribus, caeterisque requisitis iuxta Sacros Canones idoneum repletum, itaque in spiritualibus exercitatum, cum caeremoniis et solemnitatibus necessariis iuxta Sanctae Romanae Ecclesiae Riturum, ad Sacrum Presbyteratum servatis rite servandis in Domino Promovimus.

In cuius rei testimonium has literas nomine, sigilloque nostro munitas, expedire iussimus.

Datum in Civitate Angelorum, die 2^a mensis Martii A. D. 1970

L.S.

+ *Timotheus Manning*
Archiepiscopus Angelorum in California

Jacobus Franciscus Cardinalis McSherry

Dei atque sedis Apostolicae Gratia

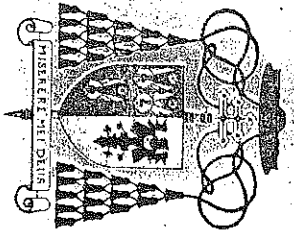

Archiepiscopus Angelorum in California

Universis et singulis litteris praesentes inspecturis notum facimus quod Anno a Nativitate Domini 1963 die vero 1^o mensis Maii Ordines Celebrantes in Cathedrali Sanctae Vibianae dilectum nobis in Christo REVERENDUM THOMAM HAVEL

examinatum et approbatum, atque in moribus, caeterisque requisitis juxta Sacros Canones idoneum repletum, itemque in spiritualibus exercitatum, cum caeremoniis et solemnitatibus necessariis juxta Sanctae Romanae Ecclesiae Ritum, ad Sacrum Presbyteratum servatis rite servandis in Domino Promovimus.

In cuius rei testimonium has litteras nomine, sigilloque nostro munitas, expedire iussimus.

Datum in Civitate Angelorum, die 1^o mensis Maii A. D. 1963

L. S.

Archiepiscopus Angelorum in California



SACRA CONGREGATIO
PRO RELIGIOSIS
ET INSTITUTIS SAECULARIBUS

F. 1

*Rescriptum die 14a Januarii 1971 a Moderatore
generali executioni mandatum testatur
Vincentius Vasey, sm.
Proc. gen.*

PROT. N. 22111/70

BEATISSIME PATER,

Sacerdos Thomas E. HAVEL, e clero archidioeceseos
Angelorum in California,

a Sanctitate Tua humiliter implorat dispensationem a vetito de quo
in articulo 29, II, Instructionis "Renovationis Causam"
ut novitiatum in Societate Mariae (Marianistarum) per-
gere valeat sine interruptione studiorum suorum acade-
micorum, ob allatas causas.

Et Deus, etc.

Vigore facultatum a Summo Pontifice concessarum, Sacra Congregatio pro Reli-
giosis et Institutis saecularibus, audito voto Procuratoris Genera-
lis, Rev.mo P. Superiori Generali committit, ut,
petitam gratiam, iuxta preces
, pro suo arbitrio et conscientia, concedat,
servatis ceteris servandis.

Contrariis quibuslibet non obstantibus.

Datum Romae, die 29 decembris 1970.

*E. Weston, sc.
Sec.*

MAR-HAVL000202

*G. Bolduc, c.s.v.
Missalis*



SACRA CONGREGATIO
PRO RELIGIOSIS
ET INSTITUTIS SAECULARIBUS

F. 1

*Rescriptum die 14a Januarii 1971 a Modestino
generali secretarii mandatum testatur
Vincenzo Vasy, Sm.
Proc. gen.*

PROT. N. 22111/70

BEATISSIME PATER,

Sacerdos Thomas E. HAVEL, e clero archidioeceseos
Angelorum in California,

a Sanctitate Tua humiliter implorat dispensationem a vetito de quo
in articulo 29, II, Instructionis "Renovationis Causam"
ut novitiatum in Societate Mariae (Marianistarum) pera-
gere valeat sine interruptione studiorum suorum acade-
micorum, ob allatas causas.

Et Deus, etc.

Vigore facultatum a Summo Pontifice concessarum, Sacra Congregatio pro Reli-
giosis et Institutis saecularibus, auditore toto Procuratoris Genera-
lis, Rev.mo P. Superiori Generali committit, ut,
petitam gratiam, iuxta preces
, pro suo arbitrio et conscientia, concedat,
servatis ceteris servandis.

Contrariis quibuslibet non obstantibus.

Datum Romae, die 29 decembris 1970.

*E. Weston, S.S.
Secr.*

MAR-HAVL 000203

G. Bolduc, C.S.V.



SACRA CONGREGATIO
PRO RELIGIOSIS
ET INSTITUTIS SAECULARIBUS

PROT. N. 23215/75

BEATISSIME PATER,

Procurator Generalis Societatis Mariae (Marianista-
rum),
a Sanctitate Tua humiliter implorat dispensationem super vetito
can. 139, par. 2 ut sacerdos THOMAS HAVEL medicinam exerce-
re valeat, ob rationes allatas.

Et Deus, etc.

Vigore facultatum a Summo Pontifice concessarum, Sacra Congregatio pro
Religiosis et Institutis saecularibus, attentis expositis, annuit pro gratia iuxta preces,
servatis ceteris de iure etiam civili servandis.

Contrariis quibuslibet non obstantibus.

Datum Romae, die 29 octobris 1975.

*Basilius Meiser, Op. Conr.
Subscr.*

*Xardone
Adiutor a Studiis*

MARIANIST NOVITIATE
Cupertino, California

April 27, 1971

The following material was given to Fr. Thomas Havel to share with him some of the material used in the Novitiate for introduction to religious life, the vows, community, category, S.M. apostolate and prayer.

INTRODUCTION TO RELIGIOUS LIFE

| | |
|------------------------|---|
| ----- | Chapter VI: Religious (from <u>Lumen Gentium</u>) |
| ----- | On the Adaptation and Renewal of Religious Life (<u>Perfectae Charitatis</u>) |
| Tillard, Jean Marie R. | Religious Life, Sacrament of God's Presence |
| Tillard, Jean Marie R. | Religious Life, Eschatological Sign |
| Paul VI | Address to General Chapters of Religious Orders and Congregations (May 23, 1964) |
| Hinnebusch, Paul | The Religious Life and the Mystery of Mary |
| Larkin, Ernest E. | Scriptural-Theological Aspects of Religious Life |
| Barrosse, Thomas | Reflections on Religious Formation |
| ----- | Theological and Psychological Aspects of a Religious Vocation |

INTRODUCTION TO CELIBACY

| | |
|-------------------|---------------------------------------|
| Brunner, August | Marriage and Chastity |
| O'Neill, David P. | Can a Celibate Be a Truly Mature Man? |
| O'Neill, David P. | The Reasons for Celibacy |
| Kennedy, Eugene | The Male Mystique |
| Baars, Conrad W. | Love, Sexuality and Celibacy |
| O'Neill, David P. | The Difficulties of Celibacy |

INTRODUCTION TO POVERTY

| | |
|-------------------|---|
| Brunner, August | Possessions and Poverty |
| Zogby, Edward G. | Vatican II, the Anawim and Christian Holiness |
| Orsy, Ladislav M. | Poverty in Religious Life |
| Wulf, Friedrich | The Spirit of Poverty |

MAR-HAVLU000205

Rose Michael, Sister

The Poor in Spirit

INTRODUCTION TO OBEDIENCE

Brunner, August

Freedom and Obedience

Tillard, J. M. R.

Common Life and Sanctification

Barrett, Sr. Mary Ruth

Obedience: A Scriptural View

Dubay, Thomas

Personal Integrity and Intellectual Obedience

Hillmann, Willibrord

Obedience as an Evangelical Perfection

Hill, Richard

The Challenge of Dialogue Obedience

McCall, John

The Psychology of the "New Breed" of Religious

INTRODUCTION TO STABILITY

Clemens, Bertrand

The Vow of Stability

Clemens, Bertrand

Conformity with Christ

Chaminade, William Joseph

Circular on Stability

Verrier, Joseph

Vow of Stability and Marian Consecration

Stefanelli, Joseph

Consecration to Mary

Backherms, Rober

The Vow of Stability and Our Marian Consecration

INTRODUCTION TO COMMUNITY

Beha, Sr. Helen Marie

Living Community (summary)

Kruse, Robert J.

Community Life: Witness to Christ

Rahner, Karl

The Unity of God and Love of Neighbor

Joachim Frederick, Brother

Charity and/or Human Love

INTRODUCTION TO CATEGORY

Whiteman, Thomas

"Category" in the Church Today

Sauvage, Msgr.

The Vocation of the Teaching Brother and His Role in the Church

Iannone, Bro. Joseph

Religious Brother: Sacrament of the Church

| | |
|---------------------------|--|
| Gutierrez, Anastasio | Teaching Brother in the Church |
| Ferree, William | Identity for the Working Brother |
| Totten, John | The Three Categories of the S.M. (part one of a preliminary study) |
| Charles Lawrence, Brother | Vocation of a Teaching Brother |
| Celestine Luke, Brother | Theology of a Teaching Brother's Vocation |
| Kaiser, Edwin G. | The Value and Dignity of Discipline |
| Hakenewerth, Quentin | Why Brothers Don't Become Priests |

INTRODUCTION TO S.M. SPIRITUALITY

| | |
|-------------------|---|
| Neubert, Emil | Synthesis of Our Characteristic Traits and of Our Obligations |
| ----- | Mariology in the Society of Mary |
| ----- | The Mariani Doctrine of Father Chaminade |
| Chabert, Bertzand | Contacting the Mysteries of Christ and Mary |
| Ferree, William | Commentary on Art. 6 of the Constitutions |
| Totten, John | The Role of the Marianists in the Family of Mary |

INTRODUCTION TO PRAYER

| | |
|----------------------|---|
| ----- | Mental Prayer in the Marianist Way of Life |
| Parker, Michael | Prayer in Christ |
| ----- | Mental Prayer |
| Parsch, Pius | Introduction to the Breviary |
| Breitenbeck, Gerard | Learning How to Pray |
| ----- | Definitions of Prayer (chart) |
| Behringer, William | Father Chaminade on Prayer |
| Sullivan, William | Personal Prayer Today (digest) |
| Kavanagh, Aidan | Religious Life and Worship |
| Catherine, Sister M. | Mental Prayer in Modern Religious Life |
| McLaughlin, Barry | "Prayer" from Nature, Grace and Religious Development |

Dubay, Thomas

Psychological Considerations in Our Approach
to Mental Prayer

Bro, Bernard

Pray Like a Poor Man

Hogan, William

The Role of the Liturgy in Religious Life

Verbillion, June

Communion, an Encounter with God

MARIANIST NOVITIATE
Cupertino, California

February 11, 1971

The following material (with the exception of Simler's
Circular #55) was given to Fr. Thomas Havel by way of
introduction to: -MARIANIST DOCUMENTATION

-HISTORY OF THE SOCIETY OF MARY
-S.M. SPIRITUALITY

Burns, Norbert

"Putting Off the Old Man" - The System of Virtues
"Putting on the New Man" - Prayer Life of Faith

Burton, Katherine
Chaminade

Clemens, Bertrand
System of Virtues

Delas, J. C.
A History of the Constitutions of the Society of Mary

Elbert, John
Filial Piety: The Ideal Devotion to Mary

Ferree, William
Father Chaminade's Devotion in Action
Father Chaminade's System of Virtues
Texts of Capital Importance in a Synthesis of the
Thought of Father Chaminade (Part One and Part Two)

Friedel, Francis
Mother of Jesus, My Mother

Gadiou, Louis
Marianist Spirituality

Hakenewerth, Quentin
Grain of Wheat
Prayer of Faith

Hoffer, Paul Joseph
The Spiritual Life According to the Writings of
Father Chaminade

Kieffer, William
Mary in Our Christ Life

Montague, George
An Introduction to the Virtues of Preparation

Neubert, Emil
Our Gift from God
Synthesis of Our Characteristic Traits and of our
obligations

MAR-HANU000209

Search, Paul
The Work of Purification

Sinler, Joseph
Circular #55: Historical Sketch of the Society of
Mary
(if this is not available, try either Garvin's "Centenary
Book of the S.M. in America" or Schellhorn's "Historical
Sketch of the S.M.")

Stefanelli, Joseph
The Historical Development of the First Chapter of Our
Constitutions

Totten, John
"The Sodality Consecration"

Vasey, Vincent
Last Years of Father Chaminade 1841-1850

Verrier, Joseph
Vow of Stability and Marian Consecration

A Study Club Project: Father Chaminade's System of Virtues

Constitutions of 1839
Constitutions of 1891 (1937 edition)
Constitutions of 1967

cc: Fr. Clemens
Fr. Tutas
Fr. Stefanelli
Bro. Richter
Bro. Carey

Fr. Thomas Havel, S.M.

FORMULA OF PERPETUAL PROFESSION

FOR THE GLORY OF THE MOST HOLY TRINITY
THE HONOR OF MARY, FOR MY SANCTIFICATION
AND THE SALVATION OF MEN, I

THOMAS HAVEL

PROMISE TO GOD AND VOW TO OBSERVE DURING
MY ENTIRE LIFE CHASTITY, POVERTY,
OBEDIENCE AND STABILITY, CONFORMABLY TO
THE CONSTITUTIONS OF THE SOCIETY OF MARY.

DONE AT Cupertino

Signed: Thomas E Havel, S.M.

10 August 1980

(day) (Month) (year)

FOR THE GLORY OF THE MOST HOLY TRINITY,
THE HONOR OF MARY
THE SALVATION OF THE WORLD,
AND TO FOLLOW CHRIST, I THOMAS HAVEL
PROMISE TO GOD AND VOW TO OBSERVE
DURING ONE YEAR
CHASTITY, POVERTY AND OBEDIENCE
CONFORMABLY TO THE RULE OF LIFE
OF THE SOCIETY OF MARY

Thomas E. Havel S.M. July 8, 1979
San Antonio, Texas

MAR-HAVL000212

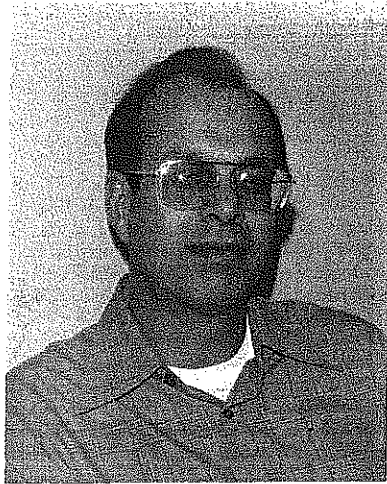

MAR-HAVL 000213

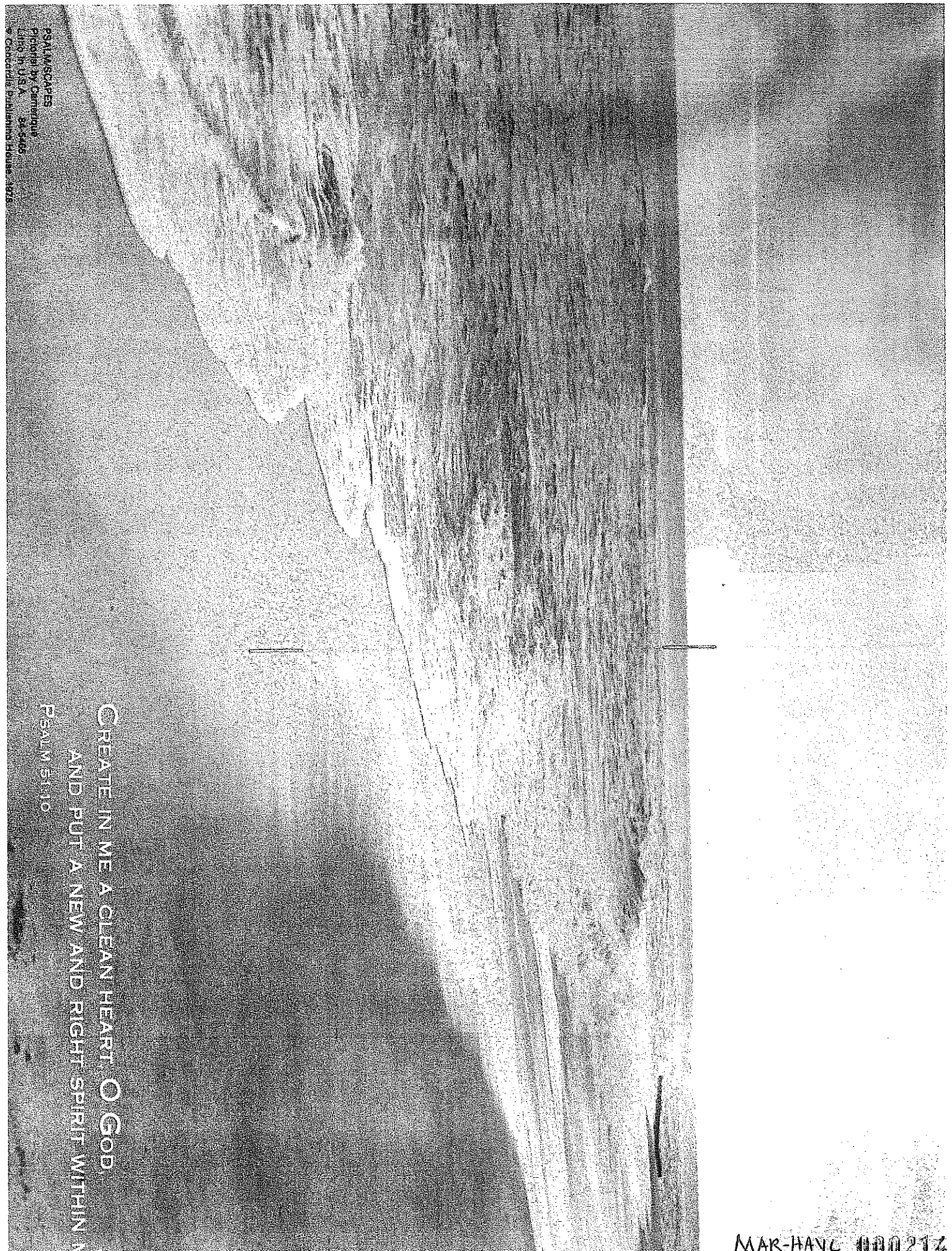

PSALMSCAPES
Picture by Catherine
Lingo in U.S.A. Bk. 6/69
© Concordia Publishing House, 1975

CREATE IN ME A CLEAN HEART, O GOD,
AND PUT A NEW AND RIGHT SPIRIT WITHIN ME.
PSALM 51:10

MAR-HAVC 000214

RENEWAL OF CONSECRATION

1. Baptismal promises renewed
2. Renewal of Vows - Fr. Havel
3. Family of Mary - renewal of consecration

O LORD OUR GOD, IN GRACE TO BLESS
 ALL MEN AND WOMEN AND LEAD THEM TO
 HOLINESS, YOU GIVE THEM YOUR BELOVED
 SON WHO HAS MADE MAN AND BORN OF THE
 VIRGIN MARY.

GRACE THAT WE MAY BE FORMED BY HER
 IN THE IMAGE OF HER FIRST-BORN SON,
 AND HELP US PARTICIPATE IN THE LOVE
 OF CHRIST FOR HIS MOTHER AND HER
 APOSTOLIC MISSION.

WHILE THE CONSECRATION THAT WE HAVE
 MADE WITH HER. MAY OUR DEVOTION
 REVEAL HER MATERNAL QUALITY OF FAITH
 AND PROTECT THE GROWTH OF THE CHURCH,
 BODY OF THE SON, JESUS CHRIST AND
 THE GROWTH OF THE FAMILY OF MARY, HER
 INSTRUMENT.

WE MAKE OUR CONSECRATION THROUGH MARY
 AND CHRIST OUR LORD. AMEN

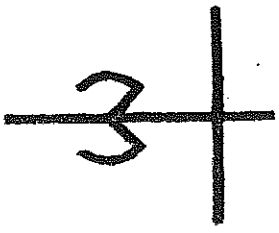

CELEBRATION OF MARIANIST
 RELIGIOUS PROFESSION OF

Reverend Thomas Havel, S.M.

Sunday, August 10, 1980

11:00 a.m.

Provinciale Chapel - Cupertino

INTRODUCTORY RITES

Entrance Antiphon - A Banquet Is Prepared
by John Kavanaugh, S.J.

A banquet is prepared with my cup running
over; my head is anointed with oil.

1. The Lord is my shepherd; I shall want nothing.
He leads me to rest in green fields;
He leads me always on the path of fidelity
To waters of cool refreshment.
2. If I have to wander through the valleys of darkness,
No evil at all will I fear.
He shall be present, guiding with kindness;
His shepherd's staff giving me comfort.
3. A banquet is prepared with my cup running over;
My head is anointed with oil.
Strength and forgiveness are always with me,
At peace in the house of the Lord.

Greeting and Welcome

In the name of the Father, and of the Son, and
of the Holy Spirit.

AMEN.

The grace and peace of God our Father and the
Lord Jesus Christ be with you.

BLESSED BE GOD, THE FATHER OF OUR LORD JESUS
CHRIST.

Renewal of Baptism

We renew together our first commitment,
made by water and the Holy Spirit.

Gloria

Glory to God in the highest,
and peace to his people on earth.
Lord God, heavenly King,
almighty God and Father,
we worship you, we give you thanks,
we praise you for your glory.
Lord Jesus Christ, only Son of the Father,
Lord God, Lamb of God,
you take away the sin of the world:
have mercy on us;
you are seated at the right hand of the Father:
receive our prayer.
For you alone are the Holy One,
you alone are the Lord,
you alone are the Most High,
Jesus Christ,
with the Holy Spirit,
in the glory of God the Father.

AMEN.

Opening Prayer

Let us pray.

God our Father,
you have caused the grace of baptism
to bear such fruit in your servants,
that they now strive to follow your Son
more closely.

Let them rightly aim
at truly evangelical perfection
and increase the holiness
and apostolic zeal of your Church.
We ask this through our Lord Jesus Christ,
your Son,

who lives and reigns with you
and the Holy Spirit, one God,
forever and ever.

AMEN.

THE LITURGY OF THE WORD

First Reading from the book of Wisdom
18:6-9

Just as you struck our enemies,
you made us glorious by calling
us to you.

Responsorial - Be Not Afraid
by Bob Dufford, S.J.

1. You shall cross the barren desert,
But you shall not die of thirst.
You shall wander far in safety
Though you do not know the way.
You shall speak your words in foreign lands
And all will understand.
You shall see the face of God and live.

The musical notation consists of three staves. The first staff has the lyrics: "Be not a - fraid. I go be -". The second staff has the lyrics: "fore you al - ways. Come fol - low Me, and". The third staff has the lyrics: "I will give you rest." The music is written in a treble clef with a key signature of one sharp (F#) and a 4/4 time signature.

2. If you pass through raging waters in the sea
You shall not drown.
If you walk amid the burning flames,
You shall not be harmed.
If you stand before the pow'r of hell
And death is at your side,
Know that I am with you through it all.
3. Blessed are your poor,
For the kingdom shall be theirs.
Blest are you that weep and mourn,
For one day you shall laugh.
And if wicked men insult and hate you
All because of Me,
Blessed, blessed are you!

Second Reading from the letter to the Hebrews
11:1-2,8-19

We will look for the city
designed and built by God.

Gospel Acclamation (sung)

Third Reading from the Gospel according to Luke
12:32-48

See that you are prepared.

Homily - Father Stefanelli:

THE LITURGY OF RELIGIOUS PROFESSION

Fr. Joe: Tom, by water and the Holy Spirit you have already been consecrated to God's service: are you resolved to unite yourself more closely to him by the new bond of religious profession?

Fr. Tom: I am.

Fr. Joe: Are you resolved to strive steadfastly for perfection in the love of God and of your neighbor by living the Gospel with all your heart and keeping the Rule of Life of the Society of Mary?

Fr. Tom: I am.

Fr. Joe: Tom, will you, through the love of Jesus, consecrate yourself with your whole being to him, and henceforth fulfill the service of God in the Society of Mary in communion with your brothers?

Fr. Tom: I will.

Fr. Joe: Will you, in order to give yourself completely to the love of Christ and to live the common life, remain celibate?

Fr. Tom: I will.

Fr. Joe:

Will you, in order that we may be of but one heart and one soul, and, that unity of service may be fully realized, discern the will of God as manifested through the Constitutions, the directives of leadership, and the decisions made in community?

Fr. Tom: I will.

At this point, the assembly will stand.

Fr. Joe:

Members of the Christian community, here gathered, you have heard Tom express his intentions. What is your wish for him?

All:

TOM, WE DESIRE THAT YOU WILL CONTINUE TO GIVE OF YOURSELF IN THE LIFE YOU HAVE CHOSEN. WE PRAY THAT THE GIFT OF LIFE YOU BRING TO OTHERS MAY ALWAYS WITNESS THE GIFT OF LOVE YOU HAVE RECEIVED FROM GOD. WE WILL CONTINUE TO HELP YOU GROW IN FAITH.

Fr. Tom then dialogues with his Brothers.

Fr. Tom:

Brothers, you have heard me share with this community my call from the Lord and my desire to respond to Him. Will you accept me as I am, full of hopes and aspirations, limitations and weaknesses? Will you pledge to me your support and assist me in fulfilling my hopes for humanity?

Brothers:

With the blessing of your family and the witness of this Christian community, we welcome you into the Society of Mary. We require you to live your life in the spirit of our Founder, William Joseph Chaminate. Be, therefore, a servant of God's Word, obedient to the call you have heard, and loving toward the persons you will encounter.

The gold ring is a symbol of tradition and fidelity in the Society of Mary, signifying consecration to the Lord through our Blessed Mother.

Let us pray.

Father, bless Tom who will wear this ring. May this symbol of consecration be a constant reminder to Tom that our life is a response to the call of Christ, a call to share more deeply in His life, death and resurrection. May this ring be a sign of your covenant with our Brother and a symbol to him of the alliance he makes with Mary and her Society. We pray in Jesus' name, he who lives and reigns forever and ever.

AMEN.

The profession of perpetual vows is made in these words:

FOR THE GLORY OF THE MOST HOLY TRINITY,
THE HONOR OF MARY,
THE SALVATION OF THE WORLD,
AND TO FOLLOW CHRIST,
I PROMISE TO GOD AND VOW TO OBSERVE
DURING MY WHOLE LIFE
CHASTITY, POVERTY, OBEDIENCE AND STABILITY
CONFORMABLY TO THE RULE OF LIFE
OF THE SOCIETY OF MARY.

Rite of Peace
General Intercessions

THE LITURGY OF THE EUCCHARIST

Offertory - I Lift Up My Soul
by Tim Manion

To You, Yah-weh, I lift up my

soul, O my God.

To You, Yah-weh, I lift up my

soul, O my God.

1. Yahweh, show Your ways to me.
Teach me Your paths
And keep me in the ways of Your truth,
For You are the God that saves me.
2. The Lord is so good, so holy,
Sinners find the way
And in all that is right He guides the humble;
The poor He leads in His pathways.
3. All day long I hope in Your goodness.
Remember Your love,
The love that You promised long ago,
And the kindness that You gave from of old.

Holy, Holy - (recited)

Holy, holy, holy Lord, God of power and might,
heaven and earth are full of your glory.
Hosanna in the highest.
Blessed is he who comes in the name of the Lord.
Hosanna in the highest.

Eucharistic Acclamation - (sung)

When we eat this bread and drink this cup,
We proclaim your death, Lord Jesus,
Until you come in glory.

Amen - (sung)

The Lord's Prayer - (sung)

Communion Song - Peace Prayer
by John Foley, S.J.

[Congregation]

1. Lord, make me a means of Your
2. Lord, make me a means of Your
3. Lord, make me a means of Your
4. Lord, grant me to seek and to
5. Lord, grant me to seek and to
6. Lord, grant me to seek and to

1. peace. Where there's ha - tred
2. peace. Where there's doubt and
3. peace. Where there's sad - ness
4. share: less to be con
5. share: to re - ceive love
6. share: to for - give in

1. grown, let me sow Your love.
2. fear, let me sow Your faith.
3. here, let me sow Your joy.
4. soled than to help con - sole.
5. less than to give love en - fee.
6. Thee, You've for - giv - en me;

1. Where there's in - jury, Lord, let for
2. In this world's des - pair, give me
3. When the dark - ness der - stood may Your
4. less be un - der - stood Thee, than to
5. just to give die in in Thee, just re -
6. for to die in in Thee is e -

1. give - ness be my sword, Lord,
2. hope in You to share, Lord,
3. light dis - pel our fears, Lord,
4. un - der - stand Your good, Lord,
5. ceiv - ing from Your tree, Lord,
6. ter - nal life to me, Lord,

1. make me a means of Your peace.
2. make me a means of Your peace.
3. make me a means of Your peace.
4. make me a means of Your peace.
5. make me a means of Your peace.
6. make me a means of Your peace.

Closing Song - Praise the Lord, My Soul
by John Foley, S.J.

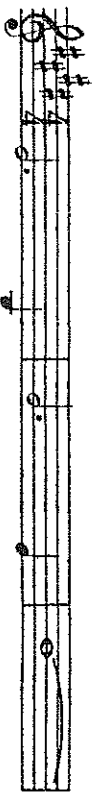

1. Praise the Lord, my soul,
2. Bless the Lord, my soul,
3. Mer - cy - full and kind,
4. Glo - ry to our God,



1. let fire and rain give praise to Him,
2. let all I am give praise to Him;
3. He knows our ways, He knows we're dust;
4. let all that is give praise to Him;



1. give praise to Him, Who is mer - ci - ful,
2. and not for - get He is kind, He for -
3. and like the flow - ers that flour - ish, we
4. give praise to Him, all you crea - tures who



1. slow to judge; bless the
2. gives our sins; bless the
3. soon must die; bless the
4. live His love; bless the

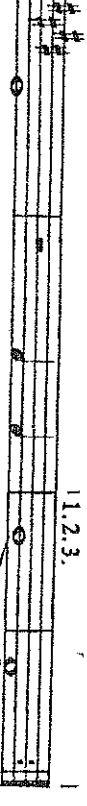

1. Lord, O my soul,
2. Lord, O my soul,
3. Lord, O my soul,
4. Lord, O my soul,
1. 2. 3.

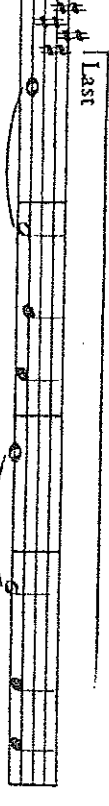

Last
4. soul, bless the Lord, O my

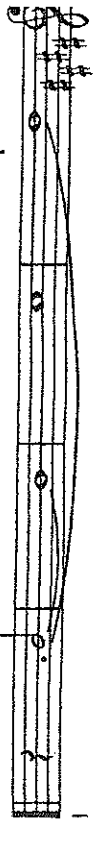



Remembering



*The Lord
is my shepherd;*

I shall not want.
He maketh me to lie down in green pastures:
He leadeth me beside the still waters.
He restoreth my soul: He leadeth me in the
paths of righteousness for His name's sake.
Yea, though I walk through the valley of the
shadow of death, I will fear no evil:
for Thou art with me;
Thy rod and Thy staff they comfort me.
Thou preparest a table before me
in the presence of mine enemies:
Thou anointest my head with oil;
my cup runneth over.
Surely goodness and mercy shall follow me
all the days of my life;
and I will dwell in the house of the Lord
forever.

The Twenty-third Psalm

Will those driving in the
funeral procession please
turn on the headlights of
their car until arrival at
the place of interment.

593 E

In Loving Memory of
Thomas E. Havel, Sr

Entered This Life
July 15, 1911

Departed This Life
January 23, 1989

Funeral Services
Rosary/Catholic Prayer Service
Wednesday, January 25, 1989
8:00 P.M.
McCune Garden Chapel

Interment
Holy Redeemer Cemetery
Montgomery, Minnesota

Arrangements By
McCune Garden Chapel
212 Main Street
Vacaville, California

MAR-HAVL 000222

Father of Rev. Thomas E. Havel, Sr

HAVAL

Tom Hall, S.M., M.D.

Georgetown - probably
the M.D. in the S.M.

Was an American priest - LA -
for 6 yrs - ordained in 1963
got to know Brothers at Camp
Park - decided to join S.M.

Fr. Clement - very enthusiastic
started per med at Loyola in
L.A. in 1969 - 1971 - accepted
at Georgetown

Starting internship at LA
County / USC Medical Ctr.
LAC / USC / MC - beginning
residency in fall of 1976
(hopefully, internal medicine)

Reserve reserves

Manila with not just
education - technical
operator - possible study

Project - do the ^{same lecture SMX} ~~project~~ as a part
of the ~~project~~ ^{SMX} ~~project~~ ^{SMX}

Search stage of ~~project~~ ^{SMX} ~~project~~ ^{SMX}

Search stage of ~~project~~ ^{SMX} ~~project~~ ^{SMX}

Search stage of ~~project~~ ^{SMX} ~~project~~ ^{SMX}

Search stage of ~~project~~ ^{SMX} ~~project~~ ^{SMX}

3/27/77 in Manila - St. John
Department in Cavendish
3/27/77

Dr. J. A. was on an out ~~project~~ ^{SMX} ~~project~~ ^{SMX}

Dr. J. A. was on an out ~~project~~ ^{SMX} ~~project~~ ^{SMX}

Dr. J. A. was on an out ~~project~~ ^{SMX} ~~project~~ ^{SMX}

Dr. J. A. was on an out ~~project~~ ^{SMX} ~~project~~ ^{SMX}

Dr. J. A. was on an out ~~project~~ ^{SMX} ~~project~~ ^{SMX}

Dr. J. A. was on an out ~~project~~ ^{SMX} ~~project~~ ^{SMX}

Dr. J. A. was on an out ~~project~~ ^{SMX} ~~project~~ ^{SMX}

20187
E66

The President and Faculty
of
Georgetown University
request the honor of your presence
at the
Commencement Exercises
of the
School of Medicine
Georgetown University
Saturday afternoon, the twenty-fourth of May
Nineteen hundred and seventy-five
at three-thirty o'clock

GEORGETOWN UNIVERSITY
School of Medicine

COMMENCEMENT ANNOUNCEMENT

SATURDAY, MAY 24, 1975

1:30 P.M.—MASS OF CELEBRATION (DAHLGREN CHAPEL)
REV. LEO P. MONAHAN PRINCIPAL CELEBRANT

3:30 P.M.—COMMENCEMENT EXERCISES (HEALY LAWN)
RECEPTION TO FOLLOW ON WHITE-GRAVENOR LAWN

In Case Of Inclement Weather, Outdoor Events Will Be Held In The
McDonough Gymnasium

Handwritten signature

MAR-HAUL 000225

CURIA GENERALIZIA DEI MARIANISTI
VIA LATINA, 22
00179 ROMA - ITALIA

The Procurator General wishes to acknowledge receipt of
the papers regarding the request for dispensation ^{from the} ~~of vows~~
(~~and laicization~~) of obligations of priestly ordination
of THOMAS E. HAVEL
and informs you that the case is under process, in the Holy See
(Congregatio de Cultu Divino et Disciplina Sacra.)
Roma, Sept 15, 1977

E.T.
Fraternally in Christ

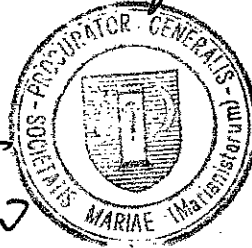

MAR-HAVL 000226



MAR-HAUL 000227

PROVINCE JUBILEE CELEBRATION
HONORING

Brother William Campbell Father Thomas Havel
Brother William Farrell Brother Vincent Steele
Father Leo Uht

Marianist Provincialate
Cupertino, California
May 21, 1988

ENTRANCE

GLORY AND PRAISE

Spirited, very deliberately

Dan Schutte, S.J.

Glo-ry and praise to our God, — who a-lone gives
 light to our days. — Man-y are the bless-ings He
 bears to those who trust in His ways. —

1. val-leys and plains, — praise the won-ders our God has
 2. In His wis-dom He streng-thens us, like gold that's
 3. Ev-'ry mo-ment of ev-'ry day our God is

- 1. done in ev-'ry heart that sings.
- 2. vails, our God is there to save.
- 3. lost, to an-swer those who pray.

© 1976, Daniel L. Schutte, S.J., and North American Liturgy Resources, 16002 N. 13rd Ave., Peoria, AZ 85029. From the songbook A DWELLING PLACE (4.50), available from NALL.

Priest:

Glo-ry to God in the high-est

People:

And on earth peace to men of good

will. We praise you. We bless you.

We wor-ship you. We glo-ri-fy you.

We give you thanks for your great glo-ry.

Lord God, heav-en-ly King.

God the Fa-ther Al-might-y.

Lord Je-sus Christ, the on-ly-be-got-

ten Son. Lord God, Lamb

of God, Son of the Fa - ther.

You, who take a - way the sins of the world,

have mer - cy on us. You, who

take a - way the sins of the world, re -

ceive our prayer. You, who sit at the

right hand of the Fa - ther, have mer - cy on

us. For you a - lone are ho -

ly. You a - lone are Lord.

You a - lone, O Je - sus Christ,

are most high. With the Ho - ly

Spir - it, in the glo - ry of God

the Fa - ther. A _____ men.

RESPONSORIAL

PRAISE, MY SOUL, THE KING OF HEAVEN

Henry F. Lyne (1834) alt.

John Goss (1869)

1. Praise, my soul, the King of heav - ven; To his
 2. Praise him for his grace and fa - vor To his
 3. Fa - ther - like he tends and spares us; Well our
 4. An - gels, help us to a - dore him; You be -

1. Feet thy 'tri - bute bring; Ran - somed, healed, re - stored, for -
 2. chil - dren in dis - tress; Praise him still the same as
 3. fee - ble frame he knows; In his hand he gen - tly
 4. hold him face to face; Sun and moon bow down be -

1. Al - le - lu - lai Praise the ev - er - last - ing King.
 2. Al - le - lu - lai Glo - rious in his faith - ful - ness.
 3. Al - le - lu - lai Wild - ly yet his mer - cy flows.
 4. Al - le - lu - lai Praise with us the God of grace.

Provincial: It is with fraternal joy and with gratitude for their example of fidelity that I invite our jubilarians forward.

My brothers, what do you ask of God and His Church?

Jubilarians: We ask that we may persevere until death in the Lord's service and in the Society of Mary.

Provincial: May the Lord, who began this good work in you, see to its completion before the day of Christ Jesus.

Jubilarian: FOR THE GLORY OF THE MOST HOLY TRINITY, THE HONOR OF MARY, THE SALVATION OF THE WORLD, AND TO FOLLOW CHRIST, I, N., AM HAPPY TO RENEW BEFORE YOU, VERY REVEREND FATHER AND MY FELLOW BROTHERS, THE VOWS OF CHASTITY, POVERTY, OBEDIENCE AND STABILITY, WHICH BY THE GRACE OF GOD I WAS PRIVILEGED TO PROFESS IN THE SOCIETY OF MARY (25, 50, 70) YEARS AGO. O MY GOD, DEIGN TO BLESS THESE HOLY VOWS, FORGET MY PAST INFIDELITIES, AND HELP ME TO BE MORE FAITHFUL IN THE FUTURE.

Provincial: Let us pray.

God our heavenly Father, we give you praise and thanks for your faithfulness to your people. We especially thank you for your blessings on our jubilarians. You have blessed your people by their service. Keep them in your peace and strength. Continue to shower your blessings upon them and grant them the power and strength to remain faithful to the commitment that they have renewed this day. We pray in the name of Jesus Christ, your Son and our Lord, who lives and reigns with you and the Holy Spirit forever and ever.

RENEWAL OF PRIESTLY COMMITMENT

Provincial: God is the source of every good intention, every resolution, and every commitment. In turn, God provides the grace to be faithful and courageous in our desires and in the words we have spoken.

Let us pray for our brother Thomas who wishes to be renewed in his dedication to Christ and as a priest of the New Covenant.

Jubilarian:

Strong and Faithful God, your only Son taught us how to be servants, one to another, and yet, he called us his friends. I, N., resolve today to unite myself ever more closely to Christ, as I did on the day of ordination twenty-five years ago. I resolve today to be a more faithful minister of all your holy mysteries, and to celebrate the liturgy of the Church with sincere devotion. I resolve today to be a teacher of the Christian faith, as I have been called to be, in integrity, honesty and wisdom, and for your glory and for the sake of your holy people. Amen.

Provincial:

May Jesus our Lord keep you close to him always and may he bring all of us, his priests and people to eternal life.

ALL:

Amen.

Agnus Dei

Ho - ly, ho - ly, ho - ly Lord
God of hosts. Heav - en and earth
are filled with your glo - ry.
Ho - san - na in the
high - est. Bless - ed is he who comes
in the name of the Lord. Ho -
san - na in the high - est.

Lamb of God, who take a - way
the sins of the world, have mer - cy
on us. Lamb of God, who take
a - way the sins of the world,
have mer - cy on us. Lamb of
God, who take a - way the sins
of the world, grant us peace.

LOW UNION

GIFT OF FINEST WHEAT

Ones Weinstendorf

Robert E. Kreses

REFRAIN: (C) (Am) (F) (Em) (Am) (Am)
 D1 Bbm Gb Fm Bbm Bbm

You sat is - fy the hun - gry heart — With

gift of fin - est wheat: Come give to us, O —

ev - ing Lord, The bread of life to eat —

VERSES:

1. As when the sheep - heard calls his sheep,
 2. With joy - ful lips sing to you
 3. Is not the cup we bless and share
 4. The mys - try of your pres - ence, Lord,
 5. You give your - self to us, O Lord: They Our The No Them

1. know and heed his voice: So when you call your
 2. praise and grat - i - tude, That you should count us
 3. blood of Christ out - poured? Do not one cup, one
 4. mor - tal tongue can tell: Whom all the world can
 5. self - less let us ba, To serve each oth - er

1. fam - 'ly, Lord, We fol - low and re - joice.
 2. wor - thy, Lord, To share this heav'n - ly food.
 3. loaf, de - clare Our one - ness in the Lord.
 4. not con - tain Comes in truth and cher - is - ty.
 5. in your name In truth and cher - is - ty.

RECESSIONAL

PRaise GOD FROM WHOM ALL BLESSINGS FLOW

Bullman Ecclis (A. 1600)

Louis Bourgeois (151)

1. Praise God from whom all bless - ings flow; Praise Him
 2. Praise all that dwell be - low the skies Let
 3. E - ter - nal are thy mer - cies, Lord, And truth
 4. Praise God from whom all bless - ings flow; Praise Him

1. ever - burn here be : low; Praise him a - bove,
 2. a - sur's praise a : rasi; Let the Re - deem -
 3. sur - nal is thy word; Thy praise shall sound
 4. ever - burn here be : low; Praise him a - bove,

1. haur'n - ly host; Praise Fa - ther, Son and Ho - ly Gh
 2. come be sung Thru' ev - 'ry land by ev - 'ry or
 3. there be those THU' gurs shall rise and set no
 4. haur'n - ly host; Praise Fa - ther, Son and Ho - ly Gh

3/29/89

Mrs. Thos. Havel

756 Yellowstone Dr.

Vacaville, CA

95688

Priest-psychiatrist's offer to settle sex suit is rejected

By Jeff Gottlieb

Mercury News Staff Writer

The Catholic priest who heads the psychiatric unit at El Camino Hospital in Mountain View has offered \$135,000 to a Pasadena woman to drop a lawsuit alleging he had sex with her when she was a teen-ager.

The woman, ██████████, rejected the offer, according to a

document written under penalty of perjury.

The document also offers ██████████ version of how she got involved with Dr. Thomas Havel and provides more details of their alleged sexual relationship, including the places where they had sex and specific sexual acts. The details are contained in interrogatories,

answers to questions Havel asked ██████████

██████████ said the sex acts started in 1968 when she was 13 and lasted until she ended the relationship when she was 18 or 19 and a student at UCLA.

Havel declined comment. His attorney, Edward Hinshaw of San Jose, said ██████████'s version of events contained numerous inaccuracies, but he declined to specify them.

██████████ said she "was lonely and was confused by her feelings brought on by her awakening sexuality" when she went to Havel for counseling in the summer of 1968.

At first, according to the document, Havel counseled her. But soon, she said, the counseling sessions turned to sex.

Woman says priest molested her often when she was young

Priest accused of molesting girl

Jeff Gottlieb
Curry News Staff Writer

A Catholic priest who is medical director of psychiatry at El Camino Hospital in Mountain View has been accused in a lawsuit of molesting a girl for several years after she sought counseling from him. The suit, filed in Los Angeles Superior Court, charged Dr. Thomas E. Havel engaged in a variety of sexual acts with a girl from 1968 to 1973, in the time she was 13 to the time she was 17. The suit says the sex acts took place in the rectory of St. Phillip the Apostle Church in Pasadena, where Havel was a priest; at his parents' home in Santa Monica; at a rectory in Gardena; and in the Santa Monica Mountains.

"You can say anything in a pleading you want," said Ward Hinshaw of San Jose, Havel's attorney. "The

See ACCUSATION, Page 2B

ACCUSATION, from Page 1B

question becomes one of proof. What can they prove?"

Asked if his client denies the charges, Hinshaw replied, "I don't think it's appropriate to try it in the newspaper."

Havel could not be contacted. He has remained at his job running the 34-bed psychiatric unit since the lawsuit was filed Nov. 3. Neilson Buchanan, chief executive officer of the publicly owned hospital, declined comment through a spokeswoman.

The Rev. John Bolin, provincial superior of the Marianist Province of the Pacific, to which Havel belongs, said lawyers advised him not to comment.

In a telephone interview, Bolin, now 34, said she sought counseling from the priest for teen-age problems, such as wanting peer acceptance. She said the sexual contact started gradually. "First he would just say, 'I want to hug you,'" she said. Eventually they graduated to kissing, and finally, to sodomy and failed attempts at intercourse, Bolin said.

The suit charges that Havel told Bolin that "the sexual acts they engaged in together would be good for her" and that he blamed her for being a "temptress" at age 13.

"Especially when we got more and more involved, he said it would help me, and he told me not to tell anyone about this," she said. Bolin said she was in love with the priest, and she hoped they would marry, feelings she expressed in a diary she wrote in code.

"Here's this 13-year-old kid being molested and thinks she's in love with him," said Bolin's attorney, M. [redacted] of Pasadena. The diary is "quite graphic. Usually whenever she sees him she ends up with this terrible little plaintive, 'I love him. I love him.'"

Bolin said her encounters with Havel continued even when he left Pasadena to attend medical school at Georgetown University in Washington. She was 16 at the time. "As soon as he got into town to visit his family, he would call me, and we would arrange to get together," she said.

Brother nearly walked in

During one of the visits, Havel's brother nearly walked in on the couple, and she hid in a closet for a half hour until he left, Bolin said. Other times their encounters would take place in the open spaces of the Santa Monica Mountains, she said.

Bolin said their sexual relationship continued until she was 18 or 19 and a student at the University of California, Los Angeles. "I finally ended it," Bolin said. "I wrote him a letter when I was a

She's unable to form a permanent attachment to any man that would be marriageable.

— M. Patricia Marrison
alleged victim's attorney

sophomore. I said, 'Don't call me when you get into town.'"

Despite her parents' shock when she told them about 15 years ago of her alleged encounters with the priest, the family took no action, Bolin said. Her father, who has a sister and an aunt who are nuns and an uncle who is a priest, "was furious" at Havel.

Havel, 51, has been on El Camino Hospital's staff since 1962 and been medical director of the psychiatric unit for three years, said Jean Altman, the hospital's public relations director.

Bolin said she realized through three years of psychotherapy how the alleged molestation had devastated her, which is why it took her so long to file the suit.

"I've been depressed my whole life," Bolin said. "When I finally discovered in my therapy that what I had been doing wasn't good for me and I wasn't to blame, I was totally enraged and I've been super-depressed since then."

Never married

She has never married. "That's one of the allegations," her attorney said. "She's unable to form a permanent attachment to any man that would be marriageable."

Bolin has been unable to hold a steady job as an adult, working as a cook, a waitress, a dental technician, a paralegal and a French teacher. She graduated from Loyola University Law School in Los Angeles in 1965 but has failed the bar exam twice. She works as a law clerk for her attorney.

The suit charges Havel perpetrated a fraud against Bolin by "lulling her into a sense of trust and then taking advantage of her," Marrison said. The suit does not specify damages, but Marrison said she will ask for \$1 million.

Marrison said the statute of limitations expires three years after a fraud is discovered. In this case, she said, it was discovered during her client's therapy.

Also named in the suit are the Marianist fathers and the Archdiocese of Los Angeles.

"I think the archdiocese is absolutely wrong to make any person they can get their hands on take a vow of chastity," Marrison said.

MAR-HANL 000235

THOMAS HAVEL
LAICIZATION DOCUMENTS
AUGUST 20, 1997

MAR-HAVL 000236

Marianist Province of the Pacific

Provincial Assistant for Religious Life

175 Phelan Avenue, San Francisco, California 94112-1822 Phone (415) 239-0841 Fax (415) 239-0848

CURRICULUM VITAE

Thomas E. Havel was born on October 12, 1937 in Blue Earth, Minnesota, to Thomas E. Havel and Elizabeth (Shilts) Havel, both Catholic. He is the oldest of three brothers and one sister.

He received his education within the Diocese of Wiwona, Minnesota, the Archdiocese of Omaha, Nebraska, and the Archdiocese of Los Angeles, California, at the following schools:

1. 1942-1945: Blue Earth Grammar School, Blue Earth, Minnesota
2. 1945-1946: St. Margaret Mary Grammar School, Omaha, Nebraska
3. 1946-1949: St. Cecilia Grammar School, Omaha, Nebraska
4. 1949-1951: St. Monica Grammar School, Santa Monica, California
5. 1951-1955: St. Monica High School, Santa Monica, California
6. 1955-1957: Queen of Angels Seminary, San Fernando, California
7. 1957-1963: St. John's Seminary, Camarillo, California

ORDERS RECEIVED

- | | | |
|-----------------------|--------------------|---------------------------|
| 1. Tonsure | October 31, 1959 | Most Rev. Alden J. Bell |
| 2. Porter & Lector | May 22, 1960 | Most Rev. Timothy Manning |
| 3. Acolyte & Exorcist | May 27, 1961 | Most Rev. Alden J. Bell |
| 4. Subdeacon | May 26, 1962 | Most Rev. Timothy Manning |
| 5. Deacon | September 29, 1962 | Most Rev. Timothy Manning |
| 6. Priest | May 1, 1963 | Cardinal James McIntyre |

All ceremonies through Diaconate took place in the seminary chapel.

Priesthood ordination took place in St. Vibiana's Cathedral, Los Angeles, California

PRIESTLY MINISTRY

1. Associate Pastor
St. Bernardine of Siena Church
Woodland Hills, California
June 1963 to August 1967
2. Associate Pastor
St. Philip's Church

MAR-HAVL 000237

Pasadena, California
August 1967 to August 1969

3. Left the Archdiocese of Los Angeles to enter Society of Mary (Marianists) in August 1969.

4. Pre-medical student

Loyola Marymount University
In Residence: Marianist Community
Gardena, California
August 1969 to August 1971

7. Medical Student
Georgetown University
Washington, D.C.
August 1971 to May 1975

8. Internship and residency in psychiatry
Los Angeles County Medical Center
In Residence: Marianist Community
Gardena, California
June 1975 to August 1979

9. In residence: Marianist Community
Cupertino, California
August 1979 to August 1980

10. Medical Director
El Camino Hospital Psychiatric Health Facility
Mountain View, California
Private psychiatric practice
Mountain View and San Francisco, California
In Residence: Marianist Community
San Jose, California
August 1980 to August 1981

11. Continuing professional work listed above
Living outside Community
August 1981 to August 1984

12. Medical Director, Behavioral Health Services
El Camino Hospital
Mountain View, California
Private psychiatric practice
Mountain View and San Francisco, California
In Residence: Marianist Formation Center
Cupertino, California

August 1984 to June 1988

13. Continuing professional work listed above
Living outside Community
June 1988 to present

SPECIFIC GROUNDS FOR SEEKING DISPENSATION

Father Havel does not lead a clerical or religious lifestyle and has not done so for a number of years. His identity is that of a physician and psychiatrist. He no longer wishes to be identified as a priest or religious. He is probably not able to make the considerable change that would be required for him to put aside the identity that he has lived since approximately 1981 to return to the priesthood and religious life.

REASONS IN SUPPORT OF THE GROUND

The Petitioner has always been interested in the area of medicine since he comes from a family in which both parents and one brother were/are working in the field. This continuing interest became an important part of his life when, on entering the Society of Mary, he was allowed to pursue medical and psychiatric studies. Over the course of years, this involvement in the practice of medicine has become the dominant focus in his life. He no longer identifies himself as a priest or religious.

His Holiness Pope John Paul II
The Vatican

Most Holy Father,

Recognizing the gravity of this request but relying on Your compassion and forgiveness, I submit this petition. With this petition I humbly request a dispensation from the obligations connected with the priesthood, religious life and from celibacy. Unfortunately, long ago I abandoned the priestly and religious life. Now I live a life from which I cannot withdraw; but I do wish to sanate this life and live as a Catholic layman in union with the Church.

For most of my life I had wanted to be a physician. In my family and among my relatives are many physicians and health care providers (e.g., my father, uncle and brother are physicians and my mother and two aunts are nurses). As a child and in grammar school I thought of becoming a physician. But, in late grammar school and toward the end of high school, I believed I wanted to be a priest. For the next eight years I studied for the priesthood and was ordained on May 1, 1963. For the next six years I was active as a priest in parish ministry. Even during this time I continued to remain interested in medicine. I requested to become a teacher in biology which was denied. In my last parish assignment, I participated in an ecumenical founding of a Free Clinic to provide medical care to the indigent in our community. At this time in 1969, after much soul searching, I determined to leave the priesthood and pursue a course of studies in medicine.

At this time of crisis, I shared my thoughts with a friend who was a brother in the Society of Mary (Marianists). He encouraged me to talk to his superiors. These superiors were looking to develop a healthcare apostolate within their Province. They generously accepted me into the Society and allowed me to pursue a medical school education. The Society obtained from the Holy See dispensations from novitiate and to attend medical school. I started immediately to attend premedical classes and then medical school. In hindsight, it might have been better to have been grounded in the priesthood and religious life by attending novitiate and living in community for an extended time; but such an expectation might have hastened my departure from priesthood and religious life.

MAR-HAVL 000240

Over the last twenty nine years, I have lived more outside than inside community and religious life. Gradually, I have fallen away from living a priestly life or performing priestly duties until for the last nine years, I have been living a functioning solely as a physician and not identified as a priest. I did not live in community while in medical school (1971-1975). Again I lived outside of community for four years (1981-1985) Finally, I moved out of community permanently in 1988. I have been living as a layman ever since then.

During this time I gradually fell away from living a priestly spiritual life. And I stopped functioning as a priest. I am presently so out of touch with the life of a priest, that I don't have the ability nor the sustaining interest to obtain the knowledge and overcome the multiple obstacles to a return to the life of a priest and religious.

In 1980 I became a treating psychiatrist and later a Medical Director of a Public Psychiatric Hospital. In 1984 to the present, I have been the Medical Directory of Psychiatry in a Community Hospital. In addition to both these positions, I have had an on going private psychiatric practice. My medical profession has been the focus of my interest and passion for the past eighteen years. As a consequence, I believe it morally impossible to leave the practice of medicine even to return to the priesthood.

Thank you for considering my petition. And I humbly ask that you grant it so that I can live a life in full union with the Church and the Sacraments.

Sincerely,

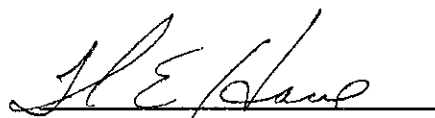
Thomas E. Havel

Date: 6/12/97

MARIANIST PROVINCIAL OFFICES

 PROVINCE OF THE PACIFIC

• 22825 SAN JUAN ROAD • P.O. BOX 1775 • CUPERTINO, CA 95015-1775 • PH (408) 253-4841 • FAX (408) 253-5280



13 June, 1997

I, Timothy E. Eden S.M., Major Superior of the Province of the Pacific of the Society of Mary (Marianists), after mature consideration of the circumstances and motives adduced in the petition of Fr. Thomas Havel, and after acknowledging my own competence to accept the case, conformably to article 4 of the Procedural Norms of the Sacred Congregation for the Doctrine of the Faith dated the 14th of October 1980, name Fr. John McEnhill S.M., Assistant Provincial for Religious Life, as Instructor of the case.

Cupertino, Ca. 13 June. 1997
 (place, day, year)

John E. McEnhill, S.M.
 Rev. John McEnhill S.M.
 (Signature of Instructor)

Timothy Eden S.M.
 V.R.F. Timothy Eden S.M.
 (Signature of Major Superior)

Seal

MAR-HAVL 000242

PETITIONER QUESTIONNAIRE
OF
THOMAS E. HAVEL, S.M.
AT
CUPERTINO CALIFORNIA
ON
MAY 11, 1997

1. *What is your name, current address, telephone number, and present occupation?*

Thomas E. Havel
334 State Street, #106
Los Altos, California 94022
(415) 361-0646

I am a physician, specializing in psychiatry, and a Medical Director of Behavioral Health Services at El Camino Hospital, Mountain View, CA.

2. *Date and place of birth?*

I was born October 12, 1937 in Blue Earth, Minnesota.

3. *Name and address of parents, if living?*

My father, Thomas E. Havel, died on January 26, 1989.
My mother, Elizabeth Shelties, died on August 12, 1993.

4. *Diocese of incardination? (or religious institute?)*

I was originally ordained and incarnated in the Archdiocese of Los Angeles, California, from May 1, 1963 until I joined the Society of Mary in August 1969.
On August 13, 1972, I made temporary vows in the Society of Mary.
On August 10, 1980, I made perpetual vows in the Society of Mary.
I had faculties in the Diocese of San Jose, California, from August 1979 until August of 1988.

5. *Religious history previous to entrance into the seminary including reception of baptism, confirmation?*

Both my parents were devout and practicing Roman Catholics all their lives. They were married in St. Cecilia's Cathedral, Omaha, Nebraska, on April 20, 1935. I was their first born on October 12, 1937. I was baptized at Ss. Peter and Paul Roman Catholic Church in Blue Earth, Minnesota, on October 31, 1937. I attended Blue Earth Public Grammar School from first through third grades. During this time, I attended religious instruction in the parish church and received my First Holy Communion there in 1945.



Rev. Stephen Tutas, S.M.

Rev. John McEnhill, S.M.

We moved to Omaha Nebraska where I attended fourth grade at St. Margaret Mary's Grammar School. There I received the Sacrament of Confirmation on May 11, 1947 I attended fifth, sixth, and half of seventh grade at St. Cecilia's Cathedral Grammar School.

My family moved to Santa Monica, California, in December 1949. There I completed seventh and eighth grades at St. Monica's Grammar School. I attended St. Monica's Boys' High School and graduated from there in May of 1955. I was active in the parish as an Altar Boy and in the Junior Legion of Mary in both grammar and high school.

My family moved to Santa Monica, California, in December 1949. there I completed seventh and eighth grades at St. Monica's Grammar School. I attended St. Monica's Boys' High School and graduated from there in May of 1955. I was active in the parish as an altar boy and in the Junior Legion of Mary in both grammar and high school.

6. *Give a detailed history of your family background, covering these points:*
- a. stability of parents' marriage;*
 - b. number of children in family;*
 - c. relationship with parents while growing up;*
 - d. religious practices and education followed in the home;*
 - e. relationships with brothers and sisters while growing up;*
 - f. economic and social background of family;*
 - g. schooling up to time of entrance into the seminary;*
 - h. personal social development, e.g., dating experience.*

My father was born of Roman Catholic parents and educated through Medical School in Roman Catholic institutions. My mother was born of a Roman Catholic mother and a Lutheran father who abandoned the family. However, she too was raised a Roman Catholic and educated through Nursing School in Roman Catholic institutions. They met at university and married in the Roman Catholic Church (St. Cecilia's Cathedral, Omaha, Nebraska on April 20, 1935). They were married fifty four years until the death of my father in 1989. They lived devoted Catholic lives and were very active in their parish and diocese. It was a very stable and loving marriage.

They had five children over a span of fifteen years. I was the oldest born on October 12, 1937. I have three brothers (Nicholas, three years younger, Richard, nine years younger, John, twelve years younger) and one sister (Mary Elizabeth, fifteen years younger).

My family was very traditional. My father was always seen at the head of the house and the final decision maker in collaboration with my mother. He was a very busy physician who was highly respected in his profession and in his community. My mother was very supportive and it was her role to raise the family and support her husband in his chosen profession. She was very active in her parish and in our schools. Our house was very open and loving. We always had members of our extended family living with us (my maternal grand mother, two maternal aunts, exchange students etc.) And our home was the gathering place of all of the children's friends.

I always knew that my parents loved me although demonstrations of affection were mostly limited to special occasions. They were strict and expected to be obeyed; but they did not use physical or verbal abuse. We were expected to live devout Catholic lives; but all things were open to discussion and lively debate.

My father was out of the home most of the time while I was growing up (three years in World War II in Europe, a seven day a week medical practice etc.). Later, when he became a

 Rev. Stephen Tutas, S.M.

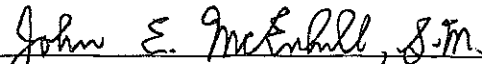
 Rev. John McEnhill, S.M.

MAR-HAVL 000244

specialist in Radiology, he was more present in the family. My mother was always there both at home in our school and parish. I loved and respected my parents both very much.

Both my parents were devout in their practice of the Faith. We, all, attended Sunday Mass and daily Mass during Lent. They were active in the parish and the Archdiocese (My mother was President of the Mothers' Club of our parish for seven years and did multiple works of corporal mercy. My father was active in the local Catholic Hospital and on several committees for the Archdiocese of Los Angeles.) They were very generous to the Church, to the Parish, the Catholic Schools through college that my siblings attended and to many missionary and charitable requests. Although we did not have any common family prayers except at meals, there was never a night when I did not see my parents knee at their bedside for their night prayers. And they expected the same from us.

While growing up my relationship with my siblings was good. Although the next oldest brother and I shared the same room and consequently had several verbal stand-offs, we always supported each other. My next two brothers were younger, so I cared for them often, especially when I was in my teenage years. My sister was fifteen years younger; so I knew her only for the first three years of her life before I left for the seminary. As adults we are all very close and are a support to one another.

My father's father only had a fourth grade education but was a banker and put his five children through Catholic College. My mother's mother came from large cattle ranch in Nebraska. Because her husband left her she was forced to work as a clerk in a tobacco shop. However, she raised my mother and put her through Nursing School. My parent's spent the first ten years of their marriage in a small town in Minnesota during the depression and immediately after World War II. My father had an heart attack at age thirty six and returned to Post Graduate School in Radiology for three years. During this time finances were tight. In 1949 we moved to California where my father was Chief Radiologist in a Catholic Hospital. We were reasonably financially secure; but never wealthy. Our social life revolved around other members of our parish, our school and professional colleagues of my father. We were close friends with the nuns, brothers and priests in our parish and school and they were often in our home.

I attended Blue Earth Public Grammar School from the first through the third grade. And at the same time regularly attended the religious education classes at Ss. Peter and Paul Catholic Church. Fourth grade was attended at St. Margaret Mary Grammar School, Omaha, Nebraska. The fifth, sixth, and half of the seventh grade were attended at St. Cecilia's Cathedral Grammar School in Omaha, Nebraska. I attended the last half of seventh grade at St. Monica's Grammar School. Finally, I attended high school at St. Monica's Boys' High School taught by the Brothers of St. Patrick.

My personal development was, I thought, rather normal. I did fairly well academically and got along well with my teachers and elders. I was active in school student government athletics and clubs. However, my dating experience was limited to group and double dating. I never had a particular girl friend. Many of the boys and girls in my group are still my friends; but I never wished for nor sought out a special or exclusive relationship with any of the girls.



Rev. Stephen Tutas, S.M.

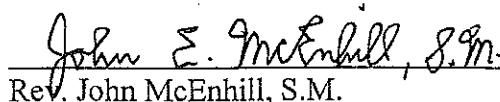

Rev. John McEnhill, S.M.

MAR-HAVL 000245

8. *When and where did you make your studies for the priesthood?*

I attended Our Lady, Queen of the Angeles, Junior Seminary in San Fernando, California from September 1955 through June 1957, where I received an A.A. degree.

I attended St. John's Major Seminary in Camarillo, California from September 1957 through May 1963. I received a B.A. in philosophy in 1959 and studied four years of theology in preparation for ordination to the priesthood for the Archdiocese of Los Angeles.

10. *When and where were you ordained to the diaconate? To the priesthood?*

I was ordained a deacon in November 1962 in the Chapel of St. John's Major Seminary, Camarillo, California.

I was ordained to the priesthood by Archbishop James Francis Cardinal McIntyre in St. Vibiana's Cathedral, Los Angeles, California on May 1, 1963 for the Archdiocese of Los



Rev. Stephen Tutas, S.M.

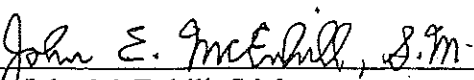

Rev. John McEnhill, S.M.
MAR-HAVL 000248

14. *Was the obligation of celibacy fully explained to you prior to your ordination to the diaconate?*
- a. *Did you fully understand the nature of this obligation?*
 - b. *Did you freely assume the obligation of celibacy?*
 - c. *Did you have any problems with sexual adjustment before ordination? Afterwards? Please explain.*

On an intellectual level, I believe that the obligation of celibacy was fully explained to me. However, since, at that time, I had no temptations in this area, I do not believe I fully understood the significance nor the enormity of the sacrifice. Nor was I able to comprehend the difficulty I would face in trying to live up to this obligation. This is not a reflection on those who were trying to educate me on this matter. Rather, it is a statement of my inability to understand it at that time. Yet, in spite of my limitations, I freely assumed the obligation of celibacy to the degree I was capable.



Rev. Stephen Tutas, S.M.

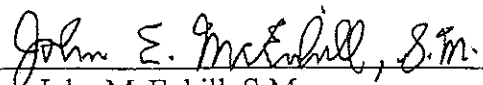

Rev. John McEnhill, S.M.

MAR-#AVL000247

My struggles with sexual adjustment both before and after ordination were, I believe, within the bounds that most Christians struggle to live up to these ideals.

18. *List your assignments after ordination.*

From June 1963 through August 1967. I was Associate Pastor at St. Bernardine of Sienna Parish, Woodland Hills, California.

From August 1967 through August 1969, I was Associate Pastor at St. Philip the Apostle Parish, Pasadena, California.

In August 1969 I left the Archdiocese of Los Angeles and entered the Society of Mary (S.M.) also called Marianists.

From August 1969 through August 1971, I was assigned to the Marianist Community at Serra High School, Gardena, California. There I attended premedical undergraduate studies at Loyola-Marymount University, Los Angeles, California.

On August 13, 1972, I made temporary vows in the Society of Mary.

From August 1971 through May 1975, I lived outside of community in a boarding house and attended Georgetown University, School of Medicine, in Washington, D.C.



 Rev. Stephen Tutas, S.M.



 Rev. John McEnhill, S.M. MAR-HAVL 000248

I made perpetual vows in the Society of Mary in August 10, 1980.

From June 1975 through August 1979, I was assigned to the Marianist Community at Serra High School in Gardena, California. During this time I did my internship and residency in psychiatry at L.A. Co. - U.S.C. Medical Center.

From August 1979 through August 1980, I was assigned to the Marianist Aspirancy Community in Cupertino, California.

From August 1980 through August 1981, I was assigned to the Marianist Community at Archbishop Mitty High School in San Jose California.

From May 1980 through September 1983, I was Medical Director of a Psychiatric Health Facility for Santa Clara County and started a private psychiatric practice which continues to this day.

From August 1981 through August 1984, I lived out of community on my own.

From August 1984 through June 1988, I lived at the Marianist Formation Center in Cupertino, California.

In February 1984 to the present, I became Medical Director of Behavioral Health Services at El Camino Hospital, Mountain View, California.

From June 1988 to the present, I have lived out of community on my own.



Rev. Stephen Tutas, S.M.



Rev. John McEnhill, S.M.

MAR-HAVL 000249

When I entered the Society of Mary, I worked with my superiors to diversify the apostolates of the Province. I and several other members, were to train in the health care professions and work together in forming an health care apostolate. Unfortunately, we were never able to put something together. As a consequence, I went on to study medicine and practice psychiatry alone. But, even in the early days in the Society, I enjoyed supporting my other brothers in their apostolates (especially teaching) and building up religious community life. It was only when I became wrapped up in my work as a physician that I slowly drifted away from religious life and active involvement in my Province.

21. *During your priesthood how faithful were you to private spiritual exercises? (Eucharistic devotion, rosary, other devotions, spiritual reading, sacrament of reconciliation, spiritual direction, spirit of mortification?)*

Initially, the habit of practicing my private spiritual exercises which I learned in the seminary was continued in my life in the parish ministry. And, when I joined the Marianists, I was very faithful to the community and private spiritual practices of the Society. But as I lived more on my own and as I became more involved in the practice of medicine, I drifted away from them until they were not practiced at all for over seventeen of the past twenty five years when I was living on my own.

22. *What expectations did you bring the priesthood that were not met?*

I don't think that any of the expectations I had before entering the priesthood were unmet. Rather new personal expectations arose in me, especially my desire to be a doctor and the personal fulfillment I found in practicing medicine and psychiatry. I enjoy living the life of a doctor while at the same time the I have become more and more estranged from priestly/religious life.

23. *In general, what failures, personal or in you priestly ministry, did you experience? How did you handle them?*

The attraction to be a doctor, in retrospect was always there; but it became a vocational issue while I was at St. Philip the Apostle Parish. I was in therapy for about two years trying to clarify this issue. I also did extensive psychological and vocational testing which reinforced what I felt, i.e., that my aptitudes and interests were in medicine. I made a decision to leave the priesthood at that time; but, while sharing my dilemma with a friend who was a member of the Society of Mary, he suggested that I talk to his superiors. I knew the Marianists from my past parish assignment and had worked with them as a chaplain in a student summer hiking program. I greatly admired their spirit and life. Since I was not leaving the priesthood so much because I disliked it; but rather because I wanted to be a doctor, I welcomed the opportunity to explore the possibility of being a doctor in the Society of Mary. The superiors at that time welcomed me into the Society of Mary and together we explored the development of an health care apostolate. I have never felt so valued and supported as I have been by the superiors and members of the Marianists. I felt that this personal vocational crisis was successfully handled when I joined the Society of Mary and was given permission by Rome to study medicine. And Rome also granted

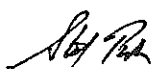

Rev. Stephen Tutas, S.M.



Rev. John McEnhill, S.M.

MAR-HAVL000250

me dispensation from the canonical novitiate since I had already been ordained a priest for six years. All this grace filled support in helping me live as priest and become a doctor seemed to work toward a successful outcome. Unfortunately, in subsequent years, when our health care apostolate failed to develop and when I realized how completely I had become involved in my medical profession, I again made the decision to leave religious and priestly life for the life of a doctor in the world.

24. *To what extent did you share with other priests problems and/or difficulties you experienced in priestly ministry?*

Initially, in the seminary, in parish life and in the early years in the Society, I had a regular spiritual directors with whom I shared every aspect of life. But, after the first time I lived outside of community and began to live the life of a layman in 1981. I gradually drifted away from spiritual direction along with my other spiritual exercises. I tried always to be honest with my superiors; but I failed take the positive steps to resolve the conflict between priestly/religious life and my life as a doctor which they advised.

25. *Was there any alcoholic or chemical dependency or serious illness whose consequences might have influenced your present decision in any way?*

No. Alcohol and drugs have never been a problem. I have had no serious physical illnesses And while I have at times been depressed; it has never interfered with my judgment.

26. *What were the reasons you left the active priesthood?*

I left the priesthood and religious life ultimately to live my life as a doctor and psychiatrist. It was a gradual shift over several years. But as each shift was made towards being a doctor exclusively, it become more difficult (until morally impossible) for me to return to the priesthood and religious life.

I don't think I knew how important being a doctor was to me until after I became one. I come from a family of health care professionals. My father was a physician. My mother was a registered nurse. One of my brothers is a physician. One of my uncles was a physician and two of my aunts were registered nurses who married health care professionals. When I applied for Medical School they asked how many of my relatives were in the health care professions, I stopped after listing twenty names. I always did well in sciences, especially biology. In my first year after ordination, I asked my ordinary for permission to teach biology in a Catholic High School, but I was turned down. When I went back to premedical undergraduate classes, I found them so interesting that I did all the extra work I could. Medical School, while difficult, was "fun". I worked hard and did well. In Internship and Residency, I did not mind the extra hours and took on the responsibilities of Chief Resident during my last year. In my career, I have been fortunate to work with the severely mentally ill in government hospitals and in private hospitals as well as run a private practice. I am even interested in the administrative aspects of health care; consequently, I have been Medical Director of two Psychiatric Facilities, for the past sixteen years.



Rev. Stephen Tutas, S.M.

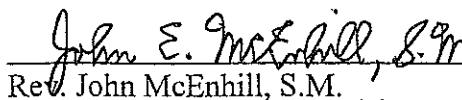

Rev. John McEnhill, S.M.

MAR-HAVL 000251

I have stopped living in the Society and functioning as a priest since June 1988. I have undertaken no assignment within the Society, nor have I participated in religious or priestly life. I do not go to retreats, attend chapters, nor live in community. Rather I have followed my own career as a psychiatrist exclusively. I have dressed as a layman, been addressed as a layperson, identified myself as a layperson. I live independently from the Society and the institutional Church and its religious institutions. I manage my own finances, own my own automobile and home, make my own future plans independently of the Society, and function in all ways as a lay person.

Conversely, my interest and ability to function as a priest and religious has continually diminished. Now I could not handle ordinary priestly sacramental ministry; to say nothing of all the other areas of priestly ministry. I have not kept up in the body of knowledge necessary to be a priest/ religious; nor have I any interest in these areas any more. My only desire is to follow my career in medicine and live as a layman in the Church.

27. *Have you applied for and were you granted a leave of absence by the bishop (or religious superior)?*

The first time I lived out of community was from July 1981 through August 1984. Then the last time began in June of 1988 and lasted until the present. At that time Diocese of San Jose no longer granted me faculties because I was not active in an approved ministry within the diocese. I have been living out side of community for nearly nine years. And I have lived continually outside of community over seventeen years of the last twenty five years.

28. *What efforts were made to resolve the conflict while on leave prior to asking for laicization? Have you sought professional counseling or therapy? What advice have you received?*

At all times I have been in communication with my superiors. After my first time out of community from 1981-1984, I returned to live community life. It was a very supportive community and, as always, my superiors were very supportive; but I did not "fit in". I felt like an outsider. I kept my role in priestly/religious life at a minimum. Then I asked for a second time out of community from 1988 to the present. Again I have been in communication with my superiors. And, after several meetings, mostly with the Head of Religious Life, it was agreed that no further progress was being made on my returning to the religious/priestly life and that laicization should be the next step.

Also, I have been in psychotherapy several times in my life. Most recently, I was in individual psychotherapy from January 1989 through April 1994. We explored all aspects of my life and of this decision. Although my therapist was not the type to give advise, I came to realize that I was no longer able to continue on in the priesthood/religious life and that being a doctor and layman would be the best way for me to live my life.



Rev. Stephen Tutas, S.M.

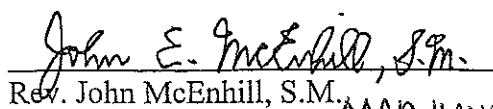

Rev. John McEnhill, S.M.

MAR-HAVL 000252

29. *What are your immediate and long-range plans? Are there plans for or has there been a marriage?*

My immediate plans would be to continue on in my present career path with my private practice and being the Medical Director of Behavioral Health Services at El Camino Hospital. My long-range plans have not been mapped out yet. I plan on practicing as a psychiatrist for the rest of my life; but I'll probably do less administrative work. I plan on living a quiet inconspicuous life as a layman in the world.

I have no plans for marriage now nor in the future.

30. *What work have you been engaged in since receiving leave of absence? Do you plan to work/live in an area where you are known as a priest?*

I have a private psychiatric practice with offices in Mountain View, California and San Francisco, California. Also, I am the Medical Director of Behavioral Health Services at El Camino Hospital in Mountain View, California.

This is the same area where I have been known as a priest. However, it has been known for nearly nine years that I have been living on my own and living the life of a layman. It is a large metropolitan area and I am not involved in the areas and with the people who knew me a priest/religious. Those people who have known me through out these years of change already are aware of the changes in my life and this request for laicization.

31. *What will be the effect on your neighbors and coworkers, if you receive the dispensation?*

It would minimize scandal by regularizing my present situation. None of my behavior nor actions would be changed. People would know that my life as a layman in the world has been regularized by the Church. It would settle peoples' puzzlement about what my standing in the Church is and put to rest people's questions about this standing. They already know that my desire is to remain a Catholic in good standing even though I not living a priestly/religious life. And laicization would tell them that I can now legitimately do so.

32. *Are you morally certain you cannot continue to function as a priest?*

Yes, I am morally certain that I cannot function as a priest. In fact I have not been doing so for long time (9 years). This has not been a hasty decision done on impulsive desires. Rather, it has been a gradual evolution from being and functioning as a priest/religious to being and functioning as a doctor. Now I am confirmed in my desire to continue to live as doctor and, hopefully as a Catholic layman in good standing with his Church.

33. *Give the names of witnesses who are in a position to testify about your character and intent prior or subsequent to your ordination.*

Brother Joseph Aspell, S.M.
20689 Forge Way, Apt. 202
Cupertino, CA 95014
(408) 252-0747

Ms. Mary Kay Coleman
Hudson Street
San Jose, CA 95124
(408) 265-5807



Rev. Stephen Tutas, S.M.



Rev. John McEnhill, S.M.

MAR-HAVL000253

34. *Do you wish to add, correct, or modify any portion of your testimony?*

No. I have nothing to add, correct, or modify.

35. *Do you swear before God that your answers are wholly true?*

Yes. I so swear.

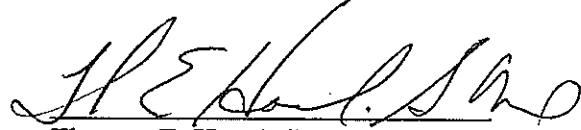

Thomas E. Havel, S.M.



Rev. Stephen Tutas, S.M.



Rev. John McEnhill, S.M.

MAR-HAVE 000254



MARIANIST PROVINCIAL OFFICES

PROVINCE OF THE PACIFIC

• 22825 SAN JUAN ROAD • P.O. BOX 1775 • CUPERTINO, CA 95015-1775 • PH (408) 253-4841 • FAX (408) 253-5280

May 1, 1997

Bro. Joseph Aspell, S.M.
20689 Forge Way, #202
Cupertino, CA 95014

Dear Joe,

I have been asked by the Very Rev. Timothy Eden, S.M., to assume the task of completing the process of laicization for Fr. Thomas Havel, S.M.

Tom has indicated to me that you would be willing to serve as a possible witness to substantiate his petition for laicization.

A copy of the questionnaire for witnesses is enclosed with this letter. The questions are far-ranging, attempting to isolate reasons which might bring a man to be dispensed from the obligations of priesthood and of celibacy. Quite possibly, you will not know various aspects of his life and hence be unable to answer some of the questions. However, insofar as possible, please give an answer to any question on which you might have information.

The new norms issued by the Holy See in 1980 ask the officials to concentrate not only on the character of the individual, but on the period of formation leading up to ordination. Was the candidate capable of assuming freely the obligations associated with the priesthood? Was the seminary itself in a position to evaluate the candidate in an adequate manner?

Although I can offer you no specifics as to the reasons being alleged for the request to be laicized, nevertheless, Tom suggests that you were generally aware of the troubles that he was undergoing. Time may have elapsed since then, but if your memory can furnish any details or information about those years, I am sure that it would be helpful in attempting to process his petition.

Your response will remain confidential and its answers will not be disclosed to Tom. Your letter will accompany his petition to the Holy See, but will not be made public in any way whatsoever.

Thanks for your help in this matter. Let's pray together for a favorable outcome for him and for all others who find themselves now desiring to resume their lives as Catholic laymen in good standing.

Sincerely yours in Christ,

John E. McEnhill, S.M.
Rev. John E. McEnhill, S.M.

Enclosure

MAR-HAVL 000255

WITNESS QUESTIONNAIRE

I solemnly swear before God that I will tell the truth, the whole truth, and nothing but the truth, so help me God and His Holy Gospels.

A. Insofar as you are able, describe the family background in relation to:

1. The educational, social, economic, and religious conditions.
His family is hard-working, well-educated. Socially they are respected and generously contribute their time and finances to community needs, especially to hospital and parish. Economically they are secure. They are educated professionals and dedicated practicing Catholics.
2. The relationship between yourself and Tom Havel.
Tom and I are fellow Marianists and friends. I had known of Tom since I had returned to our province after undergraduate studies in the midwest. I met him in the mid 1970s. I have been able to be in regular contact with him since 1979 when he came to the Aspirancy Community in Cupertino and remained in this area. We have lived in community together. I have witnessed his professional growth in the medical community. I have witnessed his gifts as a priest and a doctor in people's lives. Together, for over a year, we tended to a brother who was preparing for death. We have several mutual interests and hobbies. We have had conversations over the years in which we have shared our hopes and concerns about our own lives and for the life of the Church.
3. The relationship of Tom Havel to his siblings.
They are close. At this point in their lives they have a lot of love and compassion for each other. The death of their parents over recent years have made them even closer. They have a mutual respect for each other and for what each has accomplished in their personal and professional lives. I have attended family gatherings. Their families care for each other, visit and vacation together, enjoy each other's company.
4. The ways the family served as an influence during the time of his priestly formation and subsequent priestly ministry.
I think their influence has been key. His parents' commitment and service in the field of medicine and to church activities established a professional and ethical standard for Tom. For Tom in his priestly ministry they have been a source of encouragement and understanding.

B. Previous to his ordination: *I did not know him during this time.*

1. Was there anything said or done that caused you to doubt the future success of his priestly ministry?
2. Was there any unusual or abnormal behavior on his part during this time, such as excessive use of alcohol and/or drugs, depression, jealousy, frequent arguments?
3. Did he exhibit signs of irresponsible or impulsive decision making, unusual fears, over-reactions in situations of deep emotions?
4. Were there incidents of extreme selfishness or thoughtlessness of others' feelings?

C. At the time of his ordination: *I did not know him at this time.*

1. How would you describe his motivation?
2. Was he settled and at peace with the decision?
3. Did he exhibit enthusiasm about the event?

MAR-HAVL 000256

4. Comment on your estimation of his basic maturity, goals, system of values at the time of ordination.

5. Were there any unpleasant or negative situations that might have influenced him to be ordained at this time?

D. After his ordination to the priesthood, please comment: *I knew Tom not only after his ordination, but also after he entered our religious community and after he had been pursuing his medical profession. It is in this context that I knew Tom as a priest.*

1. Did he enjoy his priestly ministry and find it rewarding?
I think he did.

2. What expectations did he bring to the priesthood that were not met?

In our community, perhaps that the goal of having some form of medical apostolate in collaboration with other Marianist brothers and priests did not materialize.

3. Was he able to meet the needs of the people to whom he was sent to minister?

Yes. With his compassion, his great professional gifts in the field of psychiatry, his depth of understanding of Catholic thought, all these he brought to the aid of those he served.

4. In what ways did he take initiative in responding to pastoral needs in his priestly ministry?

His pursuit of strenuous medical studies was a significant way of responding to pastoral needs. In general, even in the midst of these studies, he invariably made himself available, immediately and patiently, to others both as a priest and a physician.

5. Was he able to cope with his responsibilities in the priesthood?

Yes. Yet as time went by medicine took up more and more of his time.

6. Did he get along with his co-workers, clerical and lay? Did he show consideration and sensitivity to the others in the rectory?

Yes. Very well. As a member of the community he was respected and liked. His homilies and conversation were thoughtful and illuminating.

7. In situations of conflict, could he compromise with others to resolve the differences?

In such situations I found him to be positive and constructive, not letting the personality of the individual distract from the issue..

8. Did he exhibit anger in an appropriate manner, or did he hold it in, act out in aggressive behavior, seek revenge?

Yes. He exhibited anger in an appropriate manner. I think his training in psychiatry was a help to him. He did not hold grudges

9. Did those to whom he minister perceive him as a spiritual priest?

Yes. I believe he was respected, particularly for his thoughtful homilies, his solicitousness to the needs of others, especially in emergencies.

E. Following the onset of his present difficulties, please comment:

1. How early in his priestly ministry did serious problems arise?
I am not aware of a serious problem. Rather it was a persistent problem: his distancing from community life. It became noticeable to me in his reticence in returning to community after living on his own between 1981 to 1984 when he lived on his own. Although he lived in community at the Marianist Formation Center in Cupertino from 1984 until

1988, he was very much involved the demands of his work at El Camino Hospital.

2. What were these problems and how were they resolved?
His duties at the hospital were not only full-time. They were over-time. He curbed his priestly duties in order to accommodate his medical duties.
3. Did he ever receive psychiatric help? Can you provide details?
I am aware that it is a standard practice of his profession to be also under counseling. The individual deaths of each of his parents were a great lose to him.
4. Did he have any problems with sexual adjustment. Please explain.
His adjustments were normal.
5. Do you believe that he is capable of a life-long commitment to the priesthood?
No. But I do believe that what he has been as a priest will be with him for the rest of his life, and continue to benefit others and the Church.
6. Can you provide examples illustrating where he might have failed to fulfill his priestly responsibilities?
No. Priest and physician share several qualities. Each is a full-time vocation. Tom's situation seems to me to be that of one good surpassing another.

F. Are there any other comments you would like to add?
No.

G. In your typed response, please add the following:

I, Brother Joseph Aspell, swear before God that in the foregoing testimony, I have told the truth, the whole truth, and nothing but the truth. I swear also that I will keep secret the questions proposed to me and the answers which I have given. So help me God and His Holy Gospels.

bro. joseph aspell sw

(signed)

Date: 5/25/97

May 25, 1997

I, Mary Kay Coleman, residing at 1724 Hudson Drive, San Jose California, solemnly swear before God in answering the following questions submitted to me in a Witness Questionnaire that would accompany a petition for laicization of Thomas E. Havel, S.M., that I will tell the truth, the whole truth and nothing but the truth, so help me God.

A.)

I first became acquainted with Thomas Havel at Saint Monica High School in Santa Monica, California. Boys and girls were separated in that the boys were instructed by the Brothers of St Patrick in one half of the school building while the girls were instructed in the other by Sisters of the Holy Names. Many of the activities and social events, however, of both the boys and girls school were shared, including lunchtime. So there was opportunity for friendship and time together.

Tom was a serious student. He was also an officer in the Sodality of Mary and played on the school football team. My impression of Tom during these high school years was of a very studious, spiritual boy with deep loyalties to family, school and church. He was part of a group of friends who involved themselves with many school and church activities.

Tom's family was very respected and well known in the Catholic and secular communities of Santa Monica. His father was a renowned physician at St. John's Hospital and his mother was a very down to earth woman who gave a good deal of time to St. Monica Church and school. They seemed to be a very close knit family and the Havel boys were well liked at school. Even though they were a family of standing and prestige in the community none of the Havel family took advantage of their position and in fact lived a relatively modest and unpretentious lifestyle.

My relationship with Tom in high school was not as a close friend, but as a friend none the less. Our families knew one another and his brother Nick dated my sister for a time. It was years later in 1979 that we became close friends, and remain so to this day. It was during this time that my son was an aspirant in the Society of Mary, at the Marianist Community in Cupertino when, and where, I met Tom again after so many years.

B.)

I was not the least bit surprised when I heard Tom was going into the seminary to become a priest. I thought he would make a wonderful priest. Tom, to my knowledge, didn't use alcohol and certainly not drugs. He was a person who was considerate and conciliatory towards others. He was enthusiastic, given to problem solving and a team player. I never knew him to be depressed or jealous of others. Nor did I ever see him engaged in an argument. He was a responsible, mature young man not given to impulsive decisions or over-reactions. He made appropriate emotional responses during the times and circumstances under which I knew him, previous to his ordination. He was never selfish or thoughtless of others' feelings. In fact he was quite the opposite.

MAR-HAVL 000259

C.)

I had married and moved from the Santa Monica area at the time Tom was ordained so I can not answer these questions regarding his state of mind at the time of ordination.

D.)

I can answer these questions as they apply to the years 1979 to the present since it is during this time that I have a fairly intimate knowledge of Tom's struggle and state of mind.

When I met Tom again in 1979 he was happy about being able to combine his activities as a doctor with those of being a priest. In fact some of his work involved mental health care and direction for members of his own community as well as priests and religious in the diocese as a whole. Tom participated to the fullest extent possible in the prayer life and duties of the Marianist Community to which he belonged. However, his time more and more came to be spent in the role of psychiatrist. As time went on he became conflicted with his inability to give his all to religious life as well as to his life as a doctor. This was his motivation for living outside of community.

He truly loved being a doctor and was most happy and rewarded in that form of ministry to people. I can't remember the exact year but it was during this time that Tom requested permission to live outside of community in his own apartment. At that time he was Medical Director of the Psychiatric Hospital for the County of Santa Clara and was on call a great deal of time.

I can not answer the question regarding whether or not his expectations of his priesthood were met because I don't know.

The qualities Tom has as a doctor are the same qualities he had as a priest. He is a wonderful caring person who listens to others and hears them. He has the gift, and quality, of healing the soul and mind.

I believe Tom was able to cope with the responsibilities of priesthood but there came a time when it must have become impossible to be a "good" priest - active and available to others in his community life, and a good doctor, which required a great deal of time, and many interruptions into community life.

It has always been my experience (nor have I heard to the contrary) that Tom got along very well with co-workers, clerical and lay. And that he was considerate and sensitive to others in his community.

In situations of conflict he was very able to compromise with others in order to resolve differences. He was appropriate in his emotional responses. He did not hold in appropriate expressions of anger, never acted out in an aggressive manner, and certainly is not a person who would ever seek revenge.

As I already stated, Tom's compassion for others, and his understanding of, and living out of, the spirit of the gospels in his own interior life, and in his conduct toward others, he was perceived as a spiritual person and priest.

E.)

My first awareness of Tom's serious problems with his priestly ministry was around 1980 when he considered moving out of community in order to resolve the conflicts of being able to live with the demands and duties of religious life and yet be able to meet the emotional and physical demands as a doctor in charge of a large psychiatric facility for the County of Santa Clara. This problem was temporarily resolved when he left his community and lived in a small apartment close to the hospital where he worked.

I know that Tom has had psychiatric counsel over the years, some of which having been a requirement of his profession as a psychiatrist.

Every human being, at one time or another in their lives, has problems with sexual adjustment. Tom is no exception. He has from time to time struggled with his sexuality.

I believe that at the time Tom took vows as a priest he believed that he was capable of making a life-long commitment to the priesthood, however as the years went by and Tom began to practice as a doctor, especially as a psychiatrist, he came to know within himself that his true vocation was not that of a priest, but that of a medical doctor. Since I have known Tom in both roles of priest and doctor I can in all truth say that it is my belief Tom serves God, the Church, and the community as a whole, to his fullest potential, as a doctor.

F.)

Since Tom has been outside of his priestly ministry for so many years he is no longer known as a priest in the community. In fact very few people in the area of his profession, (other doctors, nurses, patients) even know that he is a priest. It is my belief that Tom could never return to the life of the priesthood. And it is my prayer, given Tom's love of the Church, that he will be granted laicization so that he will be able to participate in the sacramental life of the Church. A Church to which he and his family have given much.

G.)

I, Mary Kay Coleman, swear before God that in the foregoing testimony, I have told the truth, the whole truth, and nothing but the truth. I swear also that I will keep secret the questions proposed to me and the answers I have given. So help me God and His Holy Gospels.

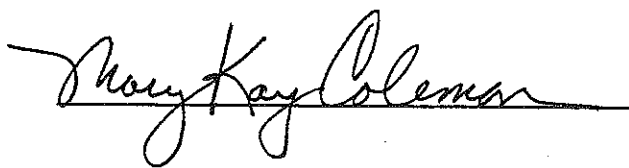
 Mary Kay Coleman
May 25, 1997
MAR-HAVL 000261

THOMAS EARL HAVEL

Mr. Havel is twenty-five years of age and comes from St. Monica's Church in Santa Monica. He has a B.A. degree from the College. He stands 10th in a class of 24, with a grade point average of 3.000.

Mr. Havel worked in the Bindery at the Seminary for a number of years and was well organized. He is inclined to be somewhat nervous and occasionally gets confused. He was not recommended for higher studies.

The general concensus was that Mr. Havel would make a good parish priest, and we feel that he will be conscientious and zealous at this work.

"Copied from the Register of Recommendations of the Rector and Faculty of St. John's Seminary, Camarillo, January 22, 1997"



Reverend Monsignor Richard A. Loomis
Vicar for Clergy

MAR-HAVL 000262

Jacobus Franciscus Cardinalis McIntyre

Dei atque sedis Apostolicae Gratia

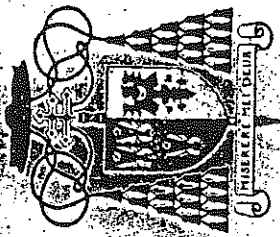
Archiepiscopus Angelorum in California



Universis et singulis litteris praesentes inspecturis notum facimus quod Anno a Nativitate Domini 1963

die vero 1^a mensis Maii Ordinibus Celebrantes in Cathedrali Sanctae Vibianae

dilectum nobis in Christo REVERENDUM THOMAM HAVEL

examinatum et approbatum, atque in moribus, caeterisque requisitis juxta Sacros Canones idoneum repertum, itemque in spiritualibus exercitatum, cum caeremoniis et solemnitatibus necessariis juxta Sanctae Romanae Ecclesiae Ritum, ad Sacrum Presbyteratum servatis rite servandis in Domino Promovimus.

In cujus rei testimonium has litteras nomine, sigilloque nostro munitas, expedire justissimus.

Datum in Civitate Angelorum, die 1^a mensis Maii A. D. 1963

L.S.

Archiepiscopus Angelorum in California

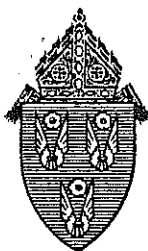

ARCHDIOCESE OF LOS ANGELES
1531 WEST NINTH STREET
LOS ANGELES, CALIFORNIA 90015

DUnkirk 8-8101

February 27, 1970

Very Reverend Bertrand Clemens
MARIANIST PROVINCIAL RESIDENCE
P.O. Box 937
Cupertino, California 95014

Very Reverend and dear Father Clemens:

We are in receipt of a letter from Father Thomas E. Havel of this Archdiocese. He requests that a letter from this jurisdiction indicate our willingness that he enter the Novitiate of the Marianist Community.

At present, Father Havel is on leave of absence from the Archdiocese for the purpose of living with members of your Society in order to determine his desire to become a Marianist. We are most willing to continue Father's leave of absence in order that you may receive him in your Novitiate, if you be so disposed.

Enclosed please find a certificate of Father's ordination.

With kindest personal regards, I am

Very sincerely yours,

+ *Timothy Manning*

TIMOTHY MANNING
Archbishop of Los Angeles

M
Encl.

MAR-HANL 000264



Timotheus Manning
Dei et Apostolicae Sedis Gratia
Archiepiscopus Angelorum
in California

Dilecto Nobis in Christo THOMAE E. HAVEL

Nos, considerantes tuam in Domino utilitatem, et rationes quas ad hoc Nobis exposuisti, salvis iure praescriptis circa ordinationis tuae titulum, praeviis etiam de tuis natalibus, vita, moribus ac studiis opportunis relationibus et testimoniis, a Nobis mature perpensis et recognitis, et causa novae incardinationis tuae ad Societas Mariae - Marianistae directis, ad tuam petitionem et instantiam, ex Nostra dioecesi Angelorum in California praesentium virtute te excardinamus excardinatumque declaramus. In nomine Patris et Filii et Spiritus Sancti. Amen.

Datum in Civitate Angelorum, sub signo sigilloque Nostris ac cancellarii Nostris subscriptione, anno Domini 1972, die vero 10a mensis Maii.

+ Timotheus Manning
 ARCHIEPISCOPUS ANGELORUM IN CALIFORNIA

DE MANDATO REVERENDISSIMI ARCHIEPISCOPI

CANCELLARIUS

MAR-HAVL 000265



SACRA CONGREGATIO
PRO RELIGIOSIS
ET INSTITUTIS SAECULARIBUS

*Rescriptum die 14a Januarii 1971 a Moderatore
generali executioni mandatum testatur
Vincentius Vasey, S.M.
Proc. gen.*

PROT. N. 22111/70

BEATISSIME PATER,

Sacerdos Thomas E. HAVEL, e clero archidioeceseos
Angelorum in California,

a Sanctitate Tua humiliter implorat dispensationem a vetito de quo
in articulo 29, II, Instructionis "Renovationis Causam"
ut novitiatum in Societate Mariae (Marianistarum) pera-
gere valeat sine interruptione studiorum suorum acade-
micorum, ob allatas causas.

Et Deus, etc.

Vigore facultatum a Summo Pontifice concessarum, Sacra Congregatio pro Reli-
giosis et Institutis saecularibus, audito voto Procuratoris Genera-
lis, Rev.mo P. Superiori Generali committit, ut, ---
---, petitam gratiam, iuxta preces
---, pro suo arbitrio et conscientia, --- concedat,
servatis ceteris servandis.

Contrariis quibuslibet non obstantibus.

Datum Romae, die 29 decembris 1970.

*E. Weston, S.S.
Sec.*

*G. Bolduc, C.S.V.
officialis*

MAR-HAVC 000266

March 17, 1972

Reverend Thomas Havel
3729 T Street
Washington, D.C. 20007

Dear Tom,

In the Provincial Council meeting of March 13, 1972, we considered your request to take temporary vows in the Society of Mary. The Council unanimously approved your request. My sincerest congratulations to you, Tom!

I am sure that you will be very happy to receive this good news about your acceptance into the Society of Mary. Also, I assure you that we are very happy and privileged to have you become a member of the Society of Mary. I am sure that your studies are coming along well, and that fact along with the acceptance now into the Society is enabling you to attain the goal that you have set for yourself as a Marianist priest in medicine.

If it is still agreeable with you, we shall plan that you would take your first vows at the close of the annual retreat in Danville. That retreat extends from August 8 to the 13th. I would encourage you very much, Tom, as you look ahead now to your profession of vows that you continue to read and study, even if for brief periods, some of the writings of the Society of Mary. I am sure that such reading and study will enable you to even grow more deeply in your understanding and love of the Society of Mary.

I am looking forward to seeing you when Brother Roger and I are in Baltimore for the Provincials and Assistant Provincials' meeting. We shall be at the Provincialate in Baltimore of the New York Province from Friday, April 7 till Sunday, April 9 included. I do hope you will be able to get away from Washington long enough to visit with us in Baltimore.

MAR-HAVL 000267

Reverend Thomas Havel

Page 2

March 17, 1972

Again, my sincerest congratulations to you, Tom, upon your acceptance into the Society of Mary. You are loved and admired by all the Marianists, we are privileged to have you join the Society of Mary. You are ever in my prayers. May God continue to bless you and your studies.

Sincerely yours in J. M. J. ,

Very Rev. Bertrand E. Clemens, S.M.
Provincial Superior

MAR-HAVL 000268



SACRA CONGREGATIO
PRO RELIGIOSIS
ET INSTITUTIS SAECULARIBUS

PROT. N. 23215/75

BEATISSIME PATER,

Procurator Generalis Societatis Mariae (Larianista-
rum);

a Sanctitate Tua humiliter imploro dispensationem super vetito
can. 139, par. 2 ut sacerdos THOMAS HAVEL medicinam exerce-
re valeat, ob rationes allatas.

Et Deus, etc.

Vigore facultatum a Summo Pontifice concessarum, Sacra Congregatio pro
Religiosis et Institutis saecularibus, attentis expositis, annuit pro gratia iuxta preces,
servatis ceteris de iure etiam civili servandis.

Contrariis quibuslibet non obstantibus.

Datum Romae, die 29 octobris 1975.

*Basilius Heiser, Sps. Com.
Subscr.*

*Sardone
Adiutor a Studiis*

MAR-HAVEL 000269

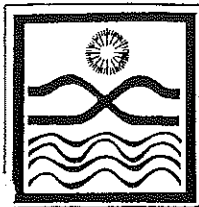

February 12, 1980

Very Reverend Joseph M. Stefanelli, S.M.
Provincial, Province of the Pacific
P. O. Box AC,
Cupertino, CA 95015

Very Reverend Father:

With this letter I formally request to make perpetual vows of poverty, chastity, obedience and stability in the Society of Mary for the Province of the Pacific.

I began living in Marianist Communities in 1969 and made my first temporary vows in 1972. Since that time I have lived in two different communities (Gardená and Alcalde Road) and have had the opportunity to know and work with many other Marianists, e.g. in the New York Province while I lived in Washington, D.C. and at the Marianist Studies Program in San Antonio in 1979. I have grown to love the Society, its members, its rule of life and its many works. I feel already permanently committed to the Society in mind and spirit if not yet by perpetual vows.

I have had the opportunity to speak often to my spiritual director, as well as, others whom I hold in esteem. All have encouraged me to seek perpetual vows at this time. And I pray that the intentions I have now of living as a son of Mary in her Society will grow stronger with each passing day.

And I hope that you and your council will find me worthy to be perpetually professed as a Marianist in this Province.

Fraternally,

Thomas E. Havel, S.M.

Thomas E. Havel, S.M.

MAR-HAVL 000270

MARIANIST PROVINCIAL OFFICES



 PROVINCE OF THE PACIFIC

• 22825 SAN JUAN ROAD • P.O. BOX 1775 • CUPERTINO, CA 95015-1775 • PH (408) 253-4841 • FAX (408) 253-5280

13 June, 1997

I, Timothy E. Eden S.M., Major Superior of the Province of the Pacific of the Society of Mary (Marianists), after mature consideration of the circumstances and motives adduced in the petition of Fr. Thomas Havel, and after acknowledging my own competence to accept the case, conformably to article 4 of the Procedural Norms of the Sacred Congregation for the Doctrine of the Faith dated the 14th of October 1980, name Fr. Stephen Tutas S.M., as Notary to record the acta of the case and to attest the acts and documents of the process.

Cupertino, CA. 13 June 1997
 (place, day, year)

Rev. Stephen Tutas S.M.
 (Signature of Notary)

Timothy Eden S.M.
 V.R.F. Timothy Eden S.M.
 (Signature of Major Superior)

Seal

MAR-HAVL 000271

Marianist Province Of The Pacific

Provincial Assistant for Religious Life

175 Phelan Avenue, San Francisco, California 94112-1822 Phone (415)239-0841 Fax (415)239-0848

July 12, 1997

His Holiness, Pope John Paul II
Vatican City

Most Holy Father:

This letter is written to support the request for dispensation for Father Thomas E. Havel, S.M., from his priestly and religious vows. I do so as the duly-appointed Instructor for this petition. I also write as a qualified mental health professional. I possess a doctoral degree in psychology and am licensed by the State of California to practice psychotherapy.

I have been meeting with Father Havel on a monthly or bi-monthly basis since September 1992. In the beginning, my efforts were directed toward helping him return to a more regular living of religious life. Father Havel made genuine efforts to free himself somewhat from the tremendous professional demands placed upon him as a psychiatrist and as the director of an in-patient psychiatric facility. This proved difficult to do. In the end, Father Havel came to the realization that his entire identity had become that of a medical doctor and a psychiatrist. The return to a religious and clerical way of living seemed not only too distant a goal but he no longer had the will to make the effort.

This realization was a traumatic one for him and he reached it over a number of interviews with me which were both sorrowful and regretful. It is my professional judgment that the decision to leave is an honest one on his part, in view of all the circumstances of his life as a Marianist.

Marianist superiors, in the past, made some serious mistakes concerning Father Havel's time of formation. The consequences of these mistakes made it difficult for him to grow in his identity as a Marianist religious. He received a dispensation from making a novitiate; instead, he began full-time medical studies at Georgetown University and lived by himself in a student apartment. During the critical years of temporary profession, even though he was technically living in a Marianist community, he was actually doing a full-time internship and residency in psychiatry at Los Angeles County Medical Center.

MAR-HAVL000272

Following perpetual profession, and during the few years that he lived in a Marianist community, he was actually fully employed as a physician and psychiatrist and was seldom home. Father Havel realizes that it was his responsibility as well as the superiors to take steps to change his life at that time; he acknowledges that he allowed the compulsive pattern of work to dominate his life.

I am respectfully asking Your Holiness to regularize the living situation for Father Havel. This would be done for the good of the Church so that scandal could be avoided. In the local Church of San Jose Father Havel is well-known and well-respected as a psychiatrist; he serves many priests and religious. I request this dispensation also so that Father Havel may re-enter the active life of the Church as a lay person; his present situation is an awkward one for him and could, over time, endanger his faith life.

Respectfully,

Father John E. McEnhill, S.M., Ph.D.

Father John E. McEnhill, S.M., Ph.D.
Provincial Assistant for Religious Life

California State License #MFC27964

KAR-HAVL 000273

DIOCESE OF SAN JOSE

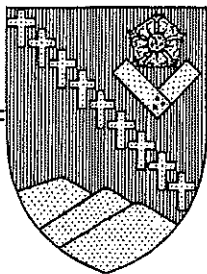

OFFICE OF THE BISHOP

July 15, 1997

Rev. Timothy Eden, SM
Marianist Provincial Offices
22825 San Juan Rd.
Cupertino CA 95015-1775

Dear Father Eden,

I want to acknowledge your letter dated June 13, 1997, but received in this office on July 10, 1997.

In response to your request, I will support your own judgment in the petition and give whatever assurance is needed that, in my personal and pastoral judgment, the laicisation of Father Thomas Havel will not be the cause or occasion of any scandal or other adverse consequence among clergy, faithful, or general community in the Diocese of San Jose.

You are welcome to append this letter to the requisite documentation for the canonical process. If the Process requires a separate letter directly to the competent dicastery, please designate to whom the letter should be addressed, and I will comply promptly.

I take this occasion to express anew my gratitude for the continued presence, witness and service of the Marianists in the Diocese of San Jose, and my prayerful support of all the members and works of the Province of the Pacific.

Faternally,

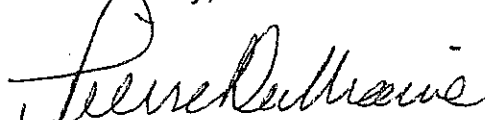
Bishop of San Jose

PDM/mc

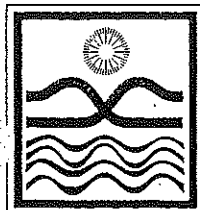

MARIANIST PROVINCIAL OFFICES

PROVINCE OF THE PACIFIC

• 22825 SAN JUAN ROAD • P.O. BOX 1775 • CUPERTINO, CA 95015-1775 • PH (408) 253-4841 • FAX (408) 253-5280

15 June, 1997

Pope John Paul II
Vatican City

Most Holy Father,

As Provincial Superior of the Marianist Province of the Pacific I am writing in support of the request of Fr. Thomas Havel for a dispensation from his priestly and religious vows. After several earlier periods of living outside of community Fr. Havel moved out of religious community permanently in 1988. Since that time he has maintained only a distant relationship with the Marianists. I am not aware of when he stopped functioning as a priest, but I know that it has been for some time and that presently he is not exercising his priesthood at all. Efforts have been made by the Provincial Administration to create with him a process of re-integration into the community. I believe Fr. Havel entered into those discussions in good faith, but there has been no success in any of those efforts. At this point I do not believe that there is a possibility of his return either to religious community or the exercise of his priesthood. His life has moved entirely in the direction of his medical practice and the lay life. I firmly believe that no good can come from continuing the fiction of his membership in the Society of Mary or functioning as a priest. For these reasons I request that you grant his petition for dispensation. It has the unanimous support of the full Provincial Council.

Thank you for considering this request.

Sincerely yours,

Fr. Timothy Eden S.M.
Provincial

MAR-HAVL 000275

MARIANIST PROVINCIAL OFFICES

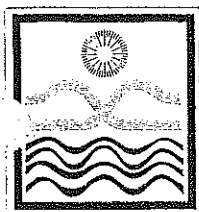

PROVINCE OF THE PACIFIC

• 22825 SAN JUAN ROAD • P.O. BOX 1775 • CUPERTINO, CA 95015-1775 • PH (408) 253-4841 • FAX (408) 253-5280

PROVINCE OF THE PACIFIC, SOCIETY OF MARY (MARIANISTS) CERTIFICATION AUTHENTICATING THE ACTS

CASE: Thomas E. Havel

By these present, I certify that the acts of the above-mentioned case contained herein are either original or exact duplicates of original writings and form authentic acts of this case to be transmitted forthwith to the Congregation for Divine Worship and the Discipline of the Sacraments.

A handwritten signature in black ink, appearing to read 'Stephen Tutas, S.M.'.

Rev. Stephen Tutas, S.M.
Notary
Province of the Pacific
Society of Mary

Given at the Provincialate
Province of the Pacific
Society of Mary
This 20th day of August 1997

MAR-HANLU00276

THOMAS E. HAVEL, S.M., M.D.
PSYCHIATRY

22683 ALCALDE RD.
P.O. BOX A.C.
CUPERTINO, CA 95015
(408) 253-6279

MAR-NAUL 000277

NAME Havel Thomas Rev. _____ of the Diocese of _____
(Family Name) (Christian Name)

GENERAL INFORMATION

Father's Name Thomas E. Havel Address 538 Marguerita, Santa Monica
Mother's Name Elizabeth S. Schiltz Address 538 Marguerita, Santa Monica
Guardian's Name _____ Address _____

Entered Postulate at _____ Date of Entrance 2-3-71
Entered Novitiate at _____ Date of Entrance 2-3-71

| Temporary Vows | | |
|----------------|---------|--------|
| Place | Date | Term |
| Danville | 8-13-72 | 1 yr |
| Baltimore | 6-23-73 | 1 yr |
| Bethesda | 6-23-74 | 1 yr |
| Honolulu | 6-7-75 | 1 yr |
| Santa Barbara | 6/13/76 | 1 year |
| | | |
| | | |
| | | |

Birth _____ Date of Entrance _____
Place Blue Earth, Minnesota (City) (State) Date 10-12-37

Baptism _____
Place Ss. Peter & Paul Church (City) (State) Date 10-27-37
Blue Earth, Minnesota (City) (State)

Confirmation _____
Place _____ (City) (State) Date _____

Perpetual Vows _____
Place _____ (City) (State) Date _____

Ordination _____
Place St. Vibiana Cathedral (City) (State) Date 5-3-63
Los Angeles, California (City) (State)

Death _____
Place _____ (City) (State) Date _____

Province of the Pacific **000078**
Withdrawal _____
Place Los Altos CA (City) (State) (Establishment) Date 1/21/98
& from priesthood

NAME Havel, Thomas

PLACES AND EMPLOYMENTS

| Date | Place | Employment | Director |
|--------|---------------------|-----------------|-------------|
| 9-1-72 | Washington DC | Student | |
| 8-75 | Gardena | Internship | Bro. Haster |
| 8-76 | " | ACTING DIRECTOR | |
| 8-79 | Cupertino Aspirancy | Student | Fr. DeLong |
| 8-80 | PaloAlto | | |
| 8-81 | Saratoga | | |
| 8-84 | Cupertino-MFC | in residence | Fr. Clemens |
| 8-85 | " | " | Fr. Hughes |
| 4/88 | Cupertino | | |
| 5/89 | Los Altos | | |
| | | | |
| | | | |
| | | | |
| | | | |
| | | | |
| | | | |
| | | | |
| | | | |
| | | | |
| | | | |
| | | | |

Academic Degrees

| Degree | Subject | Date | Conferred Place |
|--------|---------|------|-----------------|
| M. D. | | | |
| | | | |
| | | | |
| | | | |
| | | | |
| | | | |

REMARKS

000279

C O P Y

May 15, 1978

Rev. Thomas Havel, S.M.
Marianist Community
14830 S. Van Ness Ave.
Gardena, Calif. 90249

Dear Tom,

Your request for admission to a renewal of vows, together with the community evaluation forms and consultation blanks, were reviewed in Council on May 4. I am happy to be able to tell you that the Council voted favorably on your request, and that I hereby admit you to renew your vows for another year. I am sure you are familiar enough with the comments of your Brothers -- their appreciation of your devotedness to the community as Director, of your continuing growth as a Marianist, of your obvious involvement in the life of the community -- together with their regrets that your professional program continues to draw so heavily on your time and your energy.

It is my hope, and theirs, too, that this coming year will see some moderation in the demands of your professional formation, so that you can discover that important "sacred leisure" so necessary for spiritual and religious growth. It will be important, also, to program eventually some additional explicit Marianist studies into your schedule -- perhaps a summer MSP or renewal program. Meanwhile, I am confident you are doing whatever is possible to strengthen your faith life, your religious living, and your dedication to the wellbeing of others.

I want to add my personal thanks for all you do for the community, and for the concern you manifest for each member. May God continue to bless you with strength and health, and the happiness that comes from loving and serving Him.

Sincerely,

(Rev.) Joseph M. Stefanelli, S.M.
Provincial Superior

000280

C O P Y

May 23, 1978

Rev. Thomas Havel, S.M.
Marianist Community
14830 S. Van Ness Avenue
Gardena, Calif. 90249

Dear Tom,

This is an official note to confirm my telephone conversation with you, and to name you (again) Acting Director of the Gardena community. The confidence and support of your community members should be a source of encouragement to you, that they appreciate what you do as Director despite the limitations under which you have to work because of your professional formation program. Your experience these past two years has proven to them and to you that you have the ability and strength for the job, and that your role has been much more than merely "caretaker."

I agree with you that we must look forward to providing adequate leadership for the community in the future. We may, as a Province, have to rethink our approach to the selection of Directors since the present method limits our choices very much, and provides no real possibility of preparing specific persons for such offices.

Be assured of my personal thanks for all you continue to do for the community, and my support for your efforts in the future.

Sincerely,

(Rev.) Joseph M. Stefanelli, S.M.
Provincial Superior

cc Bulletin Bd

000281

SEP - 9 ANS'D

PROGRESS NOTES

+

| DATE | Aug 12 th |
|------|---|
| | |
| | Dear Joe, |
| | |
| | It has been a very busy month for me. |
| | I am on Medicine at D.C. General Hospital. |
| | We are on duty every 3rd night. And I spend |
| | my other evenings catching up on my sleep. |
| | Enclosed is my financial statement for |
| | July. The insurance policy money is from |
| | a policy I had as a secular priest. Fr. Berk |
| | had told me to use it as I see fit in my expenses. |
| | What I would like to do, since I have enough other |
| | income for the expenses of this year is to use the |
| | money to fly the two women I live c here in |
| | D.C. to the coast for the last 2 wks of my vaca- |
| | tion in February. My folks have already |
| | agreed to let them stay c them while in Southern |
| | Calif. (You probably should interview them, |
| | since they are the best judges of my conduct |
| | in community for the past 3 yrs.!!) |
| | Art Lopez wrote me concerning my |
| | ideas on the Health Service of the Province. |
| | Again I must beg off from offering an opinion |

000282

NOTES CONTINUED:

DATE

to Art. Since I won't have time to write to him.

My prayers are with the Province during this important time of year. - the newly professed, the perpetually professed, the new novices + the new assistant Provincial (there is not a better man than Ed.) and the new Heads of Spiritual Life + Apostolic Work.

Yours in Xt,
Tom

000283

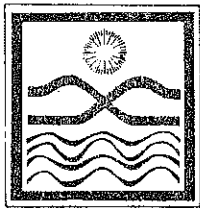

MARIANIST PROVINCIAL RESIDENCE

PROVINCE OF THE PACIFIC

• P.O. BOX 937 • (22825 SAN JUAN ROAD) • CUPERTINO, CALIF. 95014 • PH (408) 253-4841

October 31, 1978

TO WHOM IT MAY CONCERN:

This is to verify that Thomas Havel, Catholic Priest and professed religious, is a member in good standing of the Society of Mary (Marianists), Province of the Pacific (cf. Official Catholic Directory, 1977, p. 1042). This is further to verify that Father Havel has pursued, and is currently pursuing, medical studies with a view to contributing to the Marianist outreach toward the disadvantaged and the poor, as well as providing psychiatric services to priests and religious. These studies have been requested by, and are approved of by, his competent religious superiors.

During the course of these studies, and after their termination, all of Father Havel's expenses are ultimately assumed by the Society of Mary, and all his income, from whatever sources, belongs to the Society according to terms of its Constitutions (art. 25). Father Havel has conscientiously observed these stipulations of the Constitutions, and has faithfully deposited all his earnings in accounts authorized by and subject to the control of his religious superiors in keeping with his profession of religious obedience (cf. Const., arts. 35-38).

Appended is a copy of a Rescript from the Sacred Congregation of Religious and Secular Institutes, of the Vatican, authorizing him to prepare for and to practice medicine according to the norms of Canon Law of the Roman Catholic Church.

If any further clarification of Father Havel's status is required, I will be happy to furnish additional information.

Sincerely,

Rev. Joseph M. Stefanelli S.M.

Reverend Joseph M. Stefanelli, S.M.
Provincial Superior

000284

November 28, 1970

Reverend Thomas Havel
Marianist Community
Junipero Serra High School
14830 South Van Ness Avenue
Gardena, CA 90249

Dear Tom,

I just wanted to let you know that Father Steve Tutas wrote to Father Vasey on November 12 asking him to request of the Sacred Congregation a dispensation for you from the canonical novitiate. I will keep you abreast of developments as we get them. I have no idea how soon we will hear from the General Administration or from the Sacred Congregation. But I want to assure you that we will keep in touch with you as soon as I get any information. I hope all is going along very well with you in school as it has been. We appreciate all you are doing for the community at Serra and all you mean to the Brothers. It was good visiting with you when I was in Los Angeles in early November. You are in our prayers; keep us in yours.

Sincerely yours in J. M. J. ,

Reverend Bertrand E. Clemens, S.M.

000285

November 12, 1970

Reverend Vincent Vasey, S.M.
Curia Generalizia Marianisti
Via Latina 22
00179 Rome, Italy

Dear Father Vasey,

At this time, at the request of Father Clemens, I am writing to request that an applicant for admission to the Society of Mary, Father Thomas Havel, be dispensed from the required canonical novitiate and that the proposed program of preparation for the first profession of vows in the Society of Mary presented here be approved.

The Reverend Thomas E. Havel, Jr., was born October 12, 1937, in Blue Earth, Minnesota and was baptized there on October 27.

After attending schools in Minnesota, Nebraska and California, he entered the Los Angeles Archdiocesan Seminary, September 1955 and was ordained to the priesthood by James Cardinal McIntyre on May 3, 1963.

After serving as Assistant Pastor in two parishes of the Archdiocese from 1963 through the summer of 1969, he was granted a leave of absence from the Archdiocese for the purpose of living in a Marianist community while considering the possibility of applying for admission to the Society of Mary.

The leave of absence was granted for one year beginning August 1, 1969. Under date of February 27, 1970, the Archbishop of Los Angeles stated "We are most willing to continue Father's leave of absence in order that you may receive him in your Novitiate, if you be so disposed."

From August, 1969, Father Havel has been living in our Marianist community in Gardena, California, sharing the priestly responsibilities for the community with Father Frank Campanella, S.M.

000286

Reverend Vincent Vasey, S.M.

Page 2

November 12, 1970

In a letter dated March 6, 1970, Father Havel formally requested admission to the Novitiate of the Society of Mary.

In reviewing Father Havel's application for admission, the Provincial Administration was impressed by the recommendations received from both the Archdiocese and the Gardena Marianist Community.

In the meeting of March 19, the Provincial Council approved Father Havel's request for admission to the Society of Mary. In his letter to Father Havel dated March 20, Father Clemens confirmed a proposal he had made previously, that the Province would work out a special novitiate program and present this to the Sacred Congregation of Religious in Rome for approval.

You will recall that I wrote you about this in my letter of April 14 which you answered on April 22, inviting me to present the proposed program. Later, when I was in Rome, you gave me further counsel on this.

Subsequently, Father Clemens was advised to request a dispensation from the novitiate for Father Havel. I am enclosing a copy of Father Clemens's letter to Father Havel.

I am also enclosing a copy of the proposed program prepared by Father Bolin.

Our reasons for requesting approval of this exceptional program are as follows:

1. Father's personal spiritual life is exceptional. He has achieved a human and Christian maturity superior to other candidates. The proposed program of preparation for the profession of vows is designed to emphasize an intensified growth in the religious life according to the Constitutions of the Society of Mary.
2. Father Havel is presently pursuing a course of studies in medicine with an eventual specialization in psychiatry. It would be very difficult for him to interrupt his studies in order to make a canonical novitiate. His age and university requirements make it highly advisable that he continue his course of studies without interruption.
3. It is our conviction that Father Havel will be able to master the points included in Father Bolin's proposed program by guided study.

000287

Reverend Vincent Vasey, S.M.

Page 3

November 12, 1970

4. We recognize that Father Havel has already received a definite Marianist orientation by participating in province retreats and living in a Marianist community, not simply passively but quite actively as a chaplain to the community.

We would like to have this program approved for the benefit of Father Havel himself, but also for the good of the Society of Mary. Such an approval would demonstrate that the Province is able to offer a program that is adequate and appropriate to the candidate.

You will know best how to present this effectively. If you need more information, I would be happy to give you further documentation or attempt to answer specific questions. I shall be in California until November 30 when I leave for the next meeting of the Preparatory Commission.

Thank you for your help in preparing this request.

Sincerely,

Reverend Stephen R. Tutas, S.M.

Enclosures

000288

C
O
P
Y

May 18, 1970

Reverend Thomas Havel
Serra High School
14830 South Van Ness Avenue
Gardena, CA 90249

Dear Tom,

Many thanks for your letter of May 10.

In view of the fact that it is not possible to interrupt your program of studies, my suggestion is that we follow through with the series of workshops and guided reading that I had originally prepared as a possible novitiate program. Evidently, the program cannot be authorized as a canonical novitiate program, but would serve as a progressive preparation for your formal entry into the Society of Mary.

We can discuss this in more detail when you come to Cupertino. I shall be away from the Provincialate from June 13-21, conducting a retreat. I hope to see you either before or after that date.

Be assured you are in my thoughts and prayers.

Sincerely,

Father Stephen R. Tutas, S. M.

000289

C
O
P
Y

For Discussion, revision, additions, subtractions, etc.

The following is a general description of the program of formation proposed for Fr. Thomas Havel in preparation for profession of vows in the Society of Mary:

Part One: General Plan

1. The program will begin with an OPENING RETREAT under the direction of the Director of Novices
2. The main part of the formation program will center around a DIRECTED READING PROGRAM which will attempt to give both an overview of religious life in the Society of Mary, and an in-depth study of specific areas of concentration concerning the most important points of the overview.
3. Each month one of the members of the Formation Team will meet with Fr. Havel for a DIRECTION-DISCUSSION period treating the material being studied and Father's progress in preparing for profession.
4. Four times during the year there will be a QUARTERLY RETREAT for Father at the Novitiate, under the direction of the Director of Novices or one of the members of the Formation Team.
5. Finally, there will be a PRE-PROFESSION RETREAT of some length.

Part Two: Specific Areas of Reading-Study-Direction

The following areas will be treated in the overview and the in-depth treatments:

1. Marianist Documentation
2. History of the Society of Mary and of its Constitutions
3. Marianist Spirituality
4. Celibacy, Poverty, Obedience and Stability: Evangelical Living in the S.M.
5. Community of Life
6. Community of Worship
7. Community of Apostolic Action
8. Categories, Offices, Governmental Structures
9. Family of Mary
10. Theological-Scriptural-Pastoral Renewal

Part Three: Sources

There will be bibliographies provided for each area of study-discussion-direction, with core readings and supplemental readings taken from S.M. documentary sources and from recent books and periodicals.

Part Four: Formation Team

The direction of this formation program will be undertaken by a team composed of: Fr. John Bolin, Director of Novices and Chairman of the Team; Fr. Bertrend Clemens, S.M.; Bro. Roger Richter, S.M.; Fr. Stephen Tutas, S.M.; Fr. Joseph Stefanelli, S.M., and Bro. Edward Carey, S.M.

000290

is dependent on one step
following immediately upon
the other.

One does not take a year off
between undergraduate studies
& Med School, especially at
my age!

After June 10th I will be
free for 2 weeks before summer
school begins. I hope to see
you & Fr Clemens during that
time. And I hope some mutually
agreeable can be worked out.

Until then
yours in Xt,
Tom.

+

May 10th

000291

Dear Steve,

Please forgive the delay in
answering your letter.

The reply from Rome was
hardly surprising. In fact
Fr Clemens & I talked about
alternatives when I last saw
him. He felt very confident

that something could be worked
out. Unfortunately my course of
studies is very compact & the
success of the whole program

is dependent on one step following immediately upon the other.

One does not take a year off between undergraduate studies & Med School, especially at my age!

After June 10th I will be free for 2 weeks before summer school begins. I hope to see you & Fr Clemens during that time. And I hope some mutually agreeable can be worked out.

Until then
yours in Xt,
Tom.

+

May 10th

Dear Steve,

Please forgive the delay in answering your letter.

The reply from Rome was hardly surprising. In fact Fr Clemens & I talked about alternatives when I last saw

him. He felt very confident that something could be worked

out. Unfortunately my course of studies is very compact & the success of the whole program

000292

+

Feb 10, 1970

Dear Father,

Enclosed is a list of the
dates & places you asked for.
If any further information is
required, please let me know.

Thank you again for your
help in this matter & in
everything.

yours in Xt

Tom

000253

+

Feb 10, 1970

Dear Father,

Enclosed is a list of the
dates & places you asked for.

If any further information is
required, please let me know.

Thank you again for your
help in this matter & in
everything.

yours in X t

Tom

000294

NAME Havel Thomas Rev. of the Diocese of _____
 (Family Name) (Christian Name)

GENERAL INFORMATION

Father's Name Thomas E. Havel Address 538 Marguerita, Santa Monica
 Mother's Name Elizabeth S. Schiltz Address 538 Marguerita, Santa Monica
 Guardians's Name _____ Address _____

Entered Postulate at _____ Date of Entrance _____
 Entered Novitiate at _____ Date of Entrance 2-3-71

| Temporary Vows | | |
|----------------|---------|--------|
| Place | Date | Term |
| Danville | 8-13-72 | 1 yr |
| Baltimore | 6-23-73 | 1 yr |
| Bethesda | 6-23-74 | 1 yr |
| Honolulu | 6-7-75 | 1 yr |
| Santa Barbara | 6/13/76 | 1 year |
| | | |
| | | |
| | | |
| | | |

Province of the Pacific

Birth Place Blue Earth, Minnesota Date 10-12-37
 (City) (State)
 Baptism Ss. Peter & Paul Church
 Place Blue Earth, Minnesota Date 10-27-37
 (City) (State)
 Confirmation _____ Date _____
 Place _____ (City) (State)
 Perpetual Vows _____ Date 8/10/80
 Place _____ (City) (State)
 Ordination St. Vibiana Cathedral
 Place Los Angeles, California Date 5-3-63
 (City) (State)
 Death _____ Date _____
 Place _____ (City) (State)
 Withdrawal _____ T P Date _____
 Place _____ (City) (Establishment)

NAME Havel, Thomas

8/1969 - 1972 in residence at Serra (Loyola, Novitiate)
Aug 13, 1972 first vows Danville
(May 10, 1972 excardinated)
Aug. 10, 1980 final vows
Edward A. Hushaw 293-5959

NAME

PLACES AND EMPLOYMENTS

Academic Degrees

| Date | Place | Employment | Director |
|--------|---------------------|-----------------|-------------|
| 9-1-72 | Washington DC | Student | |
| 8-75 | Gardena | Internship | Bro. Haster |
| 8-76 | " | ACTING DIRECTOR | |
| 8-79 | Cupertino Aspirancy | Student | Fr. DeLong |
| 8-80 | PaloAlto | | |
| 8-81 | Saratoga | | |
| 8-84 | Cupertino-MFC | in residence | Fr. Clemens |
| 8-85 | " " | " | Fr. Hughes |
| | | | |
| | | | |
| | | | |
| | | | |
| | | | |
| | | | |
| | | | |
| | | | |
| | | | |
| | | | |
| | | | |

| Degree | Subject | Conferred | |
|--------|---------|-----------|-------|
| | | Date | Place |
| M.D. | | | |
| | | | |
| | | | |
| | | | |
| | | | |

REMARKS

0296



PROVINCE JUBILEE CELEBRATION

HONORING

Brother William Campbell Father Thomas Havel
Brother William Farrell Brother Vincent Steele
Father Leo Uht

000297

~~044296~~

Marianist Provincialate
Cupertino, California
May 21, 1988

ENTRANCE

GLORY AND PRAISE

Spirited, very deliberately Dan Schutte, S.J.

Glo-ry and praise to our God, — who a-lone gives light to our days. — Man-y are the bless-ings He bears to those who trust in His ways.

1. We, the daugh-ters and sons of Him who built the
 2. In His wis-dom He streng-thens us, like gold that's
 3. Ev-'ry mo-ment of ev-'ry day our God is

1. val-leys and plains, — praise the won-ders our God has
 2. test-ed in fire. — Though the pow-er of sin pre-
 3. wait-ing to save, — al-ways re-a-dy to seek the

1. done in ev-'ry heart that sings. —
 2. vails, our God is there to save. —
 3. lost, to an-swer those who pray. —

© 1976, Daniel L. Schutte, S.J., and North American Liturgy Resources, 10802 N. 23rd Ave., Phoenix, AZ 85029. From the songbook A DWELLING PLACE (4.50), available from NALR.

RECESSIONAL

PRAISE GOD FROM WHOM ALL BLESSINGS FLOW

William Koster (A. 1606) Louis Bourgeois (1510-156)

1. Praise God from whom all bless-ings flow; Praise Him all
 2. Praise all that dwell be-low the skies Let the Cre-
 3. E-ter-nal are thy mer-cies, Lord, And truth e-
 4. Praise God from whom all bless-ings flow; Praise Him all

1. cross-tunes here be-low; Praise Him a-bove, ye
 2. a-bove's praise a-bove; Let the Re-deem-er's
 3. ter-nal in thy word; Thy praise shall sound from
 4. cross-tunes here be-low; Praise Him a-bove, ye

1. hallow'd by host; Praise Fa-ther, Son and Ho-ly Ghost
 2. name be sung Thru' ev-'ry land by ev-'ry one.
 3. there to shore Till sung shall rise and set no more.
 4. hallow'd by host; Praise Fa-ther, Son and Ho-ly Ghost.

COMUNION

GIFT OF FINEST WHEAT

Omer Warendorf

Robert E. Krauss

REFRAIN:

Verse 1: (C) D_b

(Am) B_bm

(F) G_b

(Em) Fm

(Am) B_bm

(Dm) (Em) (C) (G) (Am) (F)
 E_bm Fm D_b A_b B_bm G_b

(Em) (Am7) (Dm) (G) (C)
 Fm B_bm7 E_bm A_b D_b

VERSES:

(C) D_b (Am) B_bm (F) G_b (C) D_b

(F) G_b (G) (Am7) (Dm) (Dm7)
 G_b A_b B_bm7 E_bm E_bm7

1. farm - ly, Lord, We fol - low and re - joice.
2. wor - thy, Lord, To share this heav - n - ly food.
3. loaf, de - clare Our one - ness in the Lord.
4. not con - tain Comes in truth and char - i - ty.
5. In your name In truth and char - i - ty.

Gloria

Priest:

People:

Agnus Dei

of God, Son of the Fa-ther.

You, who take a-way the sins of the world,

have mer-cy on us. You, who

take a-way the sins of the world, re-

ceive our prayer. You, who sit at the

right hand of the Fa-ther, have mer-cy on

us. For you a-lone are ho-

ly. You a-lone are Lord.

You a-lone, O Je-sus Christ,

Lamb of God, who take a-way

the sins of the world, have mer-cy

on us. Lamb of God, who take

a-way the sins of the world,

have mer-cy on us. Lamb of

God, who take a-way the sins

of the world, grant us peace.

Sanctus

Ho - ly, ho - ly, ho - ly Lord

God of hosts. Heav - en and earth

are filled with your glo - ry.

Ho - - - - - san - na in the

high - est. Bless - ed is he who comes

in the name of the Lord. Ho -

san - na in the high - est.

are most high. With the Ho - ly - -

Spir - it, in the glo - ry of God - -

the Fa - ther. A - - - - - men.

RESPONSORIAL

PRAISE, MY SOUL, THE KING OF HEAVEN

Henry F. Lyne (1834) alt.

John Goss (1869)

1. Praise, my soul, the King of heav - en; To his
2. Praise him for his grace and fa - vor To his
3. Fa - ther - like he tends and spares us; Well our
4. An - gels, help us to a - dore him; You be -

1. feet thy tri - bute bring; Ran - somed, healed, re - stored, for -
2. chil - dren in dis - tress; Praise him still the same as
3. fee - ble frame he knows; In his hand he gain - tly
4. hold him face to face; Sun and moon bow down be -

1. giv - en, Ev - er more his prais - es sing: Al - le - lu - lai
2. ev - er, Slow to chide and swift to bless: Al - le - lu - lai
3. bears us, Res - cues us from all our foes. Al - le - lu - lai
4. fore him, In his ho - ly dwell - ing place. Al - le - lu - lai

1. Al - le - lu - lai Praise the ev - er - last - ing King.
2. Al - le - lu - lai Glo - rious in his faith - ful - ness.
3. Al - le - lu - lai Wide - ly yet his mer - cy flows.
4. Al - le - lu - lai Praise with us the God of grace.

RENEWAL OF VOWS

Provincial:

It is with fraternal joy and with gratitude for their example of fidelity that I invite our jubilarians forward.

My brothers, what do you ask of God and His Church?

Jubilarians:

We ask that we may persevere until death in the Lord's service and in the Society of Mary.

Provincial:

May the Lord, who began this good work in you, see to its completion before the day of Christ Jesus.

Jubilarian:

FOR THE GLORY OF THE MOST HOLY TRINITY, THE HONOR OF MARY, THE SALVATION OF THE WORLD, AND TO FOLLOW CHRIST, I, N., AM HAPPY TO RENEW BEFORE YOU, VERY REVEREND FATHER AND MY FELLOW BROTHERS, THE VOWS OF CHASTITY, POVERTY, OBEDIENCE AND STABILITY, WHICH BY THE GRACE OF GOD I WAS PRIVILEGED TO PROFESS IN THE SOCIETY OF MARY (25, 50, 70) YEARS AGO. O MY GOD, DEIGN TO BLESS THESE HOLY VOWS, FORGET MY PAST INFIDELITIES, AND HELP ME TO BE MORE FAITHFUL IN THE FUTURE.

Provincial:

Let us pray.

God our heavenly Father, we give you praise and thanks for your faithfulness to your people. We especially thank you for your blessings on our jubilarians. You have blessed your people by their service. Keep them in your peace and strength. Continue to shower your blessings upon them and grant them the power and strength to remain faithful to the commitment that they have renewed this day. We pray in the name of Jesus Christ, your Son and our Lord, who lives and reigns with you and the Holy Spirit forever and ever.

ALL:

Amen.

RENEWAL OF PRIESTLY COMMITMENT

Provincial:

God is the source of every good intention, every resolution, and every commitment. In turn, God provides the grace to be faithful and courageous in our desires and in the words we have spoken.

Let us pray for our brother Thomas who wishes to be renewed in his dedication to Christ and as a priest of the New Covenant.

Jubilarian:

Strong and Faithful God, your only Son taught us how to be servants, one to another, and yet, he called us his friends. I, N., resolve today to unite myself ever more closely to Christ, as I did on the day of ordination twenty-five years ago. I resolve today to be a more faithful minister of all your holy mysteries, and to celebrate the liturgy of the Church with sincere devotion. I resolve today to be a teacher of the Christian faith, as I have been called to be, in integrity, honesty and wisdom, and for your glory and for the sake of your holy people. Amen.

Provincial:

May Jesus our Lord keep you close to him always and may he bring all of us, his priests and people to eternal life.

ALL:

Amen.

3/28/89

Mrs. Thos. Havel

756 Yellowstone Dr.

Vacaville, CA

95688

000298

The following areas are proposed for study under the direction of various Marianists:

1. History of Religious Life (Father Malley)
2. Study of the Vatican Documents on Religious Life*(Father Tutas) (Two Parts)
3. Theology of religious life, study of the Constitutions of the Society of Mary
 - a. Preliminary Chapter of the 1967 Constitutions (Father Stefanelli)
 - b. Vow of Stability and the role of the Blessed Virgin Mary (Father Clemens)
 - c. Other Chapters of the 1967 Constitutions (Father Rielly, Father Tutas) (Two Parts)
4. The life of Father Chamblade, the history of the Society of Mary (Father Hughes, Father Bach) (Two Parts)
5. The apostolate in the Society of Mary
 - a. Education (Brother Richter)
 - b. Specialized works (Father Stefanelli)
6. The priest's vocation in the Society of Mary (Father Tutas)

| | |
|---------------------------------|---|
| June 1970 (1 week) | 2 - Part I 4 - Part I 3a (June 8-12) |
| August 1970 (2-3 weeks) | Marianist retreat: Prayer (Father Bolin) (August 9-14) 1 3b |
| December, 1970 (3 weeks) | 3c - Part I |
| January, 1971 (2 weeks) | 3c - Part II |
| June-August, 1971 (3 months) | 1 2 - Part II 5a 5b 6 Systematic Study of the Marianist documents (Father Stefanelli) Marianist Retreat Marianist Studies Workshop (tentative) |

* Dogmatic Constitution on the Church, Chapter VI: Religious
Decree on the Appropriate Renewal of the Religious Life

Proposed novitiate program for Father Thomas Havel

Evidently, Father Thomas Havel has achieved a human and Christian maturity superior to other candidates. The program is designed, therefore, to emphasize an intensified growth in the religious life according to the Constitutions of the Society of Mary.

Father Havel is presently pursuing a course of studies in medicine with an eventual specialization in psychiatry.

Our proposal is that Father Havel follow a series of intensive workshops from June, 1970 through the summer of 1971, at the conclusion of which he could be approved to profess vows as a member of the Society of Mary.

Throughout the years of his professional studies, Father Havel could participate in further workshops to deepen his knowledge and aid his practice of the religious life in the Society of Mary.

The proposed workshops would be characterized as periods of prayer and guided study and research.

I would be responsible for the overall direction of the program and for the personal external direction. Father would be encouraged to work regularly with a Marianist priest for confession and spiritual direction.

It is understood that Father would continue to reside in our Gardena community while attending classes at Loyola University, coming to Cupertino for the various workshops. Father's complete and significant participation in the total life of the Gardena community is an important element in this program.

000300



CONGREGATIO DE CULTU DIVINO
ET DISCIPLINA SACRAMENTORUM

Prot. N. 1809/97/S

Romae, die 6 decembris 1997

Societatis Mariae

Taxa pro expensis ab Instituto Religioso solvenda :

Causa dispens. ac dimission.: **THOMAS E. HAVEL**

£.100.000.=.....



Inscriptio Procuratori Generali S.M.

PAGATO
CASSIERE
Congr. per Culto Divino e
la Disciplina dei Sacramenti
17 DIC. 1997

000301

d) in iisdem vero Institutis studiorum gradus superioris ab Auctoritate ecclesiastica non dependentibus nullam disciplinam proprie theologiam vel cum ipsa intime conexam tradere potest;

e) in Institutis autem studiorum gradus inferioris dependentibus ab Auctoritate ecclesiastica munere directivo vel officio docendi fungi nequit nisi Ordinarius, pro suo prudenti iudicio et remoto scandalo, ad minus docendi quod attinet, aliter decernere aestimaverit. Eadem lege tenetur sacerdos dispensatus in tradenda Religione in Institutis eiusdem generis non dependentibus ab Auctoritate ecclesiastica.

6. Per se presbyter a sacerdotali coelibatu dispensatus et a fortiori matrimonio iunctus, abesse debet a locis in quibus eius antecedens condicio nota est. Ordinarius loci commorationis oratoris tamen, audito quatenus opus erit, Ordinario incardinationis vel Superiore maiori religioso, dispensare poterit ab ista clausula Rescripti, si oratoris praesentia scandalum paritura non praevideatur.

7. Denique ei aliquod opus pietatis vel caritatis imponatur.

8. Notificatio dispensationis fieri potest vel personaliter per notarium aut ecclesiasticum actuarium vel per «epistulas perscriptas» (raccomandata, certificada, enregistrée, registered, einschreiben). Orator unum exemplar restituere debet rite subsignatum ad fidem receptionis et acceptionis eiusdem dispensationis ac simul etiam praeceptorum.

9. Tempore autem opportuno Ordinarius competens breviter ad Congregationem de peracta notificatione referat et, si qua tandem fidelium admiratio adsit, prudenti explicatione provideat.

Contrariis quibuscumque minime obstantibus.

Ex Aedibus Congregationis, die 6 decembris 1997.

CONCORDAT CUM ORIGINALI

quod in Archivo huius

Congregationis asservatur.

mae die 16 DIC. 1997

(+ Georgius Medina Estévez)
Archiep. Pro-Praefectus

(+ Gerardus Majella Agnelo)
Archiep. Secretarius

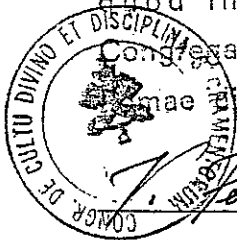

Ferrara, Subscr.

Dies notificationis Jan 21, 1998

J. E. Haul

Subsignatio Oratoris in signum acceptionis

Rer. John Renni, SM

Subsignatio Ordinarii

000302



CONGREGATIO DE CULTU DIVINO ET DISCIPLINA SACRAMENTORUM

PROT. N. 1809/97/S

D.nus THOMAS E. HAVEL, sacerdos, Societatis Mariae.

petiit dispensationem a sacerdotali coelibatu et ab omnibus oneribus sacrae Ordinationi conexas.

SS.mus D. N. Ioannes Paulus, Papa II,

die 6 decembris 1997

habita relatione de casu a Congregatione de Cultu Divino et Disciplina Sacramentorum, precibus annuit iuxta sequentes rationes:

1. Dispensatio vim habet ab ipso momento concessionis.
2. Dispensationis Rescriptum, a competenti Ordinario oratori notificetur et amplectitur inseparabiliter dispensationem a sacerdotali coelibatu et simul amissionem status clericalis. Numquam oratori fas est duo illa elementa seiungere, seu prius accipere et alterum recusare. Si vero orator est religiosus, Rescriptum concedit etiam dispensationem a votis. Idemque insuper secumfert absolutionem a censuris, quatenus opus sit.
3. Notitia concessionis dispensationis adnotetur in libris baptizatorum paroeciae oratoris.
4. Quod attinet ad celebrationem canonici matrimonii, applicandae sunt normae quae in Codice Iuris Canonici statuuntur. Ordinarius vero curet ut res caute peragantur sine pompa vel exteriore apparatu.
5. Auctoritas ecclesiastica, ad quam spectat Rescriptum oratori notificare, hunc enixe hortetur, ut vitam Populi Dei, ratione congruendi cum nova eius vivendi condicione, participet, aedificationem praestet et ita amantissimum Ecclesiae filium se exhibeat. Simul autem eidem notum faciat ea quae sequuntur:
 - a) sacerdos dispensatus eo ipso amittit iura statui clericali propria, dignitates et officia ecclesiastica; ceteris obligationibus cum statu clericali conexas non amplius adstringitur;
 - b) exclusus manet ab exercitio sacri ministerii, iis exceptis de quibus in cann. 976, 986, § 2 ac propterea nequit homiliam habere. Insuper nequit fungi ministerio extraordinario sacrae Communionis distribuendae nec potest officium gerere directivum in ambitu pastoralis;
 - c) item nullum munus absolvere potest in Seminariis et in Institutis aequiparatis. In aliis Institutis studiorum gradus superioris, qui quocumque modo dependent ab Auctoritate ecclesiastica, munere directivo vel officio docendi fungi nequit;

000303

d) in iisdem vero Institutis studiorum gradus superioris ab Auctoritate ecclesiastica non dependentibus nullam disciplinam proprie theologiam vel cum ipsa intime conexam tradere potest;

e) in Institutis autem studiorum gradus inferioris dependentibus ab Auctoritate ecclesiastica munere directivo vel officio docendi fungi nequit nisi Ordinarius, pro suo prudenti iudicio et remoto scandalo, ad munus docendi quod attinet, aliter decernere aestimaverit. Eadem lege tenetur sacerdos dispensatus in tradenda Religione in Institutis eiusdem generis non dependentibus ab Auctoritate ecclesiastica.

6. Per se presbyter a sacerdotali coelibatu dispensatus et a fortiori matrimonio iunctus, abesse debet a locis in quibus eius antecedens condicio nota est. Ordinarius loci commorationis oratoris tamen, audito quatenus opus erit, Ordinario incardinationis vel Superiore maiori religioso, dispensare poterit ab ista clausula Rescripti, si oratoris praesentia scandalum paritura non praevideatur.

7. Denique ei aliquod opus pietatis vel caritatis imponatur.

8. Notificatio dispensationis fieri potest vel personaliter per notarium aut ecclesiasticum actuarium vel per «epistulas perscriptas» (raccomandata, certificada, enregistrée, registered, einschreiben). Orator unum exemplar restituere debet rite subsignatum ad fidem receptionis et acceptionis eiusdem dispensationis ac simul etiam praeceptorum.

9. Tempore autem opportuno Ordinarius competens breviter ad Congregationem de peracta notificatione referat et, si qua tandem fidelium admiratio adsit, prudenti explicatione provideat.

Contrariis quibuscumque minime obstantibus.

Ex Aedibus Congregationis, die 6 decembris 1997.

CONCORDAT CUM ORIGINALI

quod in Archivo huius Congregationis asservatur.

die 16 DIC. 1997

(+ Georgius Medina Estévez)
Archiep. Pro-Praefectus

(+ Gerardus Majella Agnelo)
Archiep. Secretarius

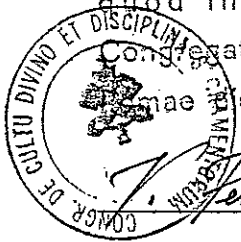

J. Ferrara, Subsecr.

Dies notificationis Jan 21, 1998

J. E. Haul
Subsignatio Oratoris in signum acceptionis

Rer John Renni, SM
Subsignatio Ordinarii

000304



CONGREGATIO DE CULTU DIVINO ET DISCIPLINA SACRAMENTORUM

PROT. N. 1809/97/S

D.nus THOMAS E. HAVEL, sacerdos, Societatis Mariae,

petiit dispensationem a sacerdotali coelibatu et ab omnibus oneribus sacrae Ordinationi conexas.

SS.mus D. N. Ioannes Paulus, Papa II,

die 6 decembris 1997

habita relatione de casu a Congregatione de Cultu Divino et Disciplina Sacramentorum, precibus annuit iuxta sequentes rationes:

1. Dispensatio vim habet ab ipso momento concessionis.
2. Dispensationis Rescriptum, a competenti Ordinario oratori notificetur et amplectitur inseparabiliter dispensationem a sacerdotali coelibatu et simul amissionem status clericalis. Numquam oratori fas est duo illa elementa seiungere, seu prius accipere et alterum recusare. Si vero orator est religiosus, Rescriptum concedit etiam dispensationem a votis. Idemque insuper secumfert absolutionem a censuris, quatenus opus sit.
3. Notitia concessionis dispensationis adnotetur in libris baptizatorum parroeciae oratoris.
4. Quod attinet ad celebrationem canonici matrimonii, applicandae sunt normae quae in Codice Iuris Canonici statuuntur. Ordinarius vero curet ut res caute peragantur sine pompa vel exteriore apparatu.
5. Auctoritas ecclesiastica, ad quam spectat Rescriptum oratori notificare, hunc enixe hortetur, ut vitam Populi Dei, ratione congruendi cum nova eius vivendi condicione, participet, aedificationem praestet et ita amantissimum Ecclesiae filium se exhibeat. Simul autem eidem notum faciat ea quae sequuntur:
 - a) sacerdos dispensatus eo ipso amittit iura statui clericali propria, dignitates et officia ecclesiastica; ceteris obligationibus cum statu clericali conexas non amplius adstringitur;
 - b) exclusus manet ab exercitio sacri ministerii, iis exceptis de quibus in cann. 976, 986, § 2 ac propterea nequit homiliam habere. Insuper nequit fungi ministerio extraordinario sacrae Communionis distribuendae nec potest officium gerere directivum in ambitu pastoralis;
 - c) item nullum munus absolvere potest in Seminariis et in Institutis aequiparatis. In aliis Institutis studiorum gradus superioris, qui quocumque modo dependent ab Auctoritate ecclesiastica, munere directivo vel officio docendi fungi nequit;

000305

Priest accused of molesting girl

By Jeff Gottlieb
Mercury News Staff Writer

A Catholic priest who is medical director of psychiatry at El Camino Hospital in Mountain View has been accused in a lawsuit of molesting a girl for several years after she sought counseling from him.

The suit, filed in Los Angeles Superior Court, charges that Dr. Thomas E. Havel engaged in a variety of sexual acts with [redacted] from 1968 to 1973, from the time she was 13 to the time she was 17.

The suit says the sex acts took place in the rectory of St. Phillip the Apostle Church in Pasadena, where Havel was a priest; at his parents' home in Santa Monica; at a rectory in Gardena; and in the Santa Monica Mountains.

"You can say anything in a pleading you want," said Edward Hinshaw of San Jose, Havel's attorney. "The
See ACCUSATION, Page 2B

000306



CONGREGATIO DE CULTU DIVINO
ET DISCIPLINA SACRAMENTORUM

Romae, die 17 Septembris 1997

Prot. N. 1809/97/S

Reverendissime Pater,

die 15 Septembris 1997 huc rite pervenerunt acta processus
administrativi pro dispensatione ab obligationibus sacrae Ordinationis et a votis in favorem
P.i THOMAS E. HAVEL presbyteri istius Instituti.

Eadem acta sub n. 1809/97/S in tabulario Dicasterii persignata sunt.

Quam primum ac iuxta proportionata tempora, de eorumdem
pertractatione nuntium habebis.

Quo par est obsequio, me profiteor

In Domino

Reverendissimo Patri

P. ENRIQUE TORRES

Procuratori Generali S.M.

(Via Latina, 22

00179 R O M A)

000307

For your information and files

1

GEORGETOWN UNIVERSITY MEDICAL CENTER • WASHINGTON, D.C.

a postgraduate course in

neurology

under the direction of
Margaret Abernathy, M.D.
Desmond O'Doherty, M.D.
Department of Neurology

— March 17-21, 1980, 8:00 am - 5:00 pm

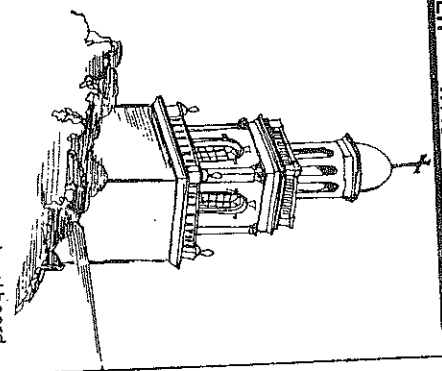

This intensive review of neurology is designed for psychiatrists preparing for written and oral board examinations. In addition to lectures, demonstrations and case discussions, the course will provide opportunities to observe film, live and/or simulated patient examinations. Emphasis will be placed on effective case analysis and presentation, including differential diagnosis.

Topics include: convulsive disorders, cerebrovascular disease, degenerative and demyelinating disorders, infections, neoplasms, neuro-ophthalmology, neuro-otology and neuromuscular disorders. There will be lectures on diagnostic procedures, including EEG, EMG, neuro-radiology and spinal fluid examination.

Lectures held in Room L44, Medical Dental Building, Georgetown University Medical Center.

As an institution accredited for continuing medical education, the Georgetown University Medical School certifies that this continuing medical education offering meets the criteria for approximately 40 credit hours in Category 1 of the Physician's Recognition Award of the American Medical Association, provided it is used and completed as designed.

For further information call Ms. Carol Willard, Course Coordinator (202) 625-7408.

*TUITION: \$350 payable in advance

APPLICATION

Concentrated Course — March 17-21, 1980, 8:00 am - 5:00 pm

Name _____ Phone _____ Zip _____
Address _____ State _____ Degree _____ Year _____
Medical School _____

Make check payable to DEPARTMENT OF NEUROLOGY and mail with this form to:

Margaret Abernathy, M.D., Department of Neurology
Georgetown University Medical Center
3800 Reservoir Road, N.W., Washington, D.C. 20007

*Cancellation Policy: A \$25 administrative fee will be retained should you cancel your course reservation. In order to refund the balance, we must receive written notice of withdrawal one week before the course begins.

Request by J. H. ... for special studies in preparation of Psychiatric Boards 4/2

Clinical Neurology For Psychiatrists

Parts I and II

Sponsored by The Office of Continuing Medical Education
Albert Einstein College of Medicine

Under the direction of **David M. Kaufman, M.D.**

Courses in New York and Los Angeles designed for Psychiatrists preparing for Parts I and II of the American Board of Psychiatry and Neurology. w consist of lectures, with videotape examples and practice audiovisual examinations.

Part I New York — March 28, 29 & 30, 1980
8:30AM - 5:00PM

The New York Academy of Medicine
Two East 103 Street, New York, NY

Part II Los Angeles — April 11 & 12, 1980
Hotel Bonaventure 5th & Figueroa

9:00AM — 5:00PM

New York — October 4 & 5, 1980
The New York Academy of Medicine

Part I— (30) Part II— (20) hours of Category I
FOR FURTHER INFORMATION CONTACT
Office of Continuing Medical Education
Albert Einstein College of Medicine
1300 Morris Park Avenue, Bronx, New York 10
(212) 430-2822

000308

C O P Y

February 1, 1978

Rev. Thomas Havel, S.M.
Marianist Community
14830 S. Van Ness Avenue
Gardena, Calif. 90249

Dear Tom,

Your letter caught me just before I leave for Hawaii. Thanks for the information on your plans. I talked to Bob Hoppe, and we O.K. your plans for therapy and for the car. Thanks to your folks for their thoughtfulness. Bob will be down your way shortly and you can see him about any further details.

Congratulations on your election to the Provincial Chapter! I only hope it does not place too large a demand on your already tight schedule.

I received nothing definite from Ken on his Chicago - Dayton trip. I would appreciate if you could send me at least the dates of departure and scheduled return.

Best wishes, prayers, greetings to all.

Sincerely,

(Rev.) Joseph Stefanelli, S.M.
Provincial Superior

000309

7

C O P Y

December 29, 1977

Rev. Thomas Havel, S.M.
Marianist Community
14830 S. Van Ness Avenue
Gardena, California 90249

Dear Tom,

This is just a brief follow-up to my visit with your community. I am sorry we did not find more time to reflect together on some aspects of the community life, but your schedule and mine didn't leave much leisure. I will try to indicate here my general impressions.

I found the spirit of the house generally good, positive, and encouraging. All the religious are appreciative of what you do as Director, especially since they realize the burden of professional duties which weighs upon you. Your personal interest in each of them is commendable and is a source of strength in the house. There seems general satisfaction with the community meetings and the functioning of the House Council.

There seem to be still some unresolved undercurrents in the area of community prayer life - presence, choice of singing, adequate preparation. I hope you can help Pat and the Office of Zeal address these areas of community prayer. My own personal impression is that more could be done to help the community "pray" the Hours - choice of readings, adequate pauses for reflection, background information on the psalms, etc. I realize that busy schedules leave little time for this, and that is perhaps the major weakness of the community. Lip service to the priority of community must eventually face the hard realities of priorities and choices. Dedication to various apostolic engagements should overflow from the fullness of community prayer and living, and not be in competition with them. And a strong community life will be the best means of attracting others to share our Marianist life.

I want to encourage you and the community to continue your efforts at community development and at sharing the Marianist presence. We all realize, I am sure, that the community cannot do everything, either for its own growth or in the apostolate; that is why it is so important to constantly review priorities and evaluate means and methods.

May this New Year bring all of you much peace and joy in the Lord.

Sincerely,

000310

(Rev.) Joseph M. Stefanelli, S.M.

C O P Y

3 May 1977

Reverend Thomas Havel, S. M.
Marianist Community
14830 South Van Ness Avenue
Gardena, California 90249

Dear Tom,

No doubt our conversation over the phone about your appointment as Director will rob this letter of any element of surprise, but for the sake of the record: At our Council meetings last week, we reviewed your request for renewal of vows as well as the consultation of the community held on that occasion. I am happy to inform you that you are hereby granted permission to renew your temporary vows for one year, at the time of your annual retreat. If I understood you correctly, this retreat will probably take place sometime in November.

When I see you up here later this month, I will try to share with you some of the comments and reflections of your Brothers, so that their fraternal concern may encourage and support you. May Our Lord continue to bless you and your work, both professionally and in the community.

Sincerely,

Reverend Joseph Stefanelli, S. M.

000311

C O P Y

2 May 1977

Reverend Thomas Havel, S. M.
Marianist Community
14830 So. Van Ness Avenue
Gardena, California 90249

Dear Tom,

Following our Council deliberations and my telephone conversation with you, I am hereby appointing you as Acting Director of the Gardena Community for another year. The work you have done in the past year, and the responsive support of your community, indicate that you are well qualified to fulfill this function. I realize the bind placed upon you by your work schedule, and can only hope, with you, that "next year it will be easier!"

The community will undergo a considerable change in membership over the summer, and I urge you to set aside some "community orientation days" sometime in August when all the members of the community can be present and you can, all together, map out some directions and desiderata for the new 1977-1978 year. I hope to see you up here in Cupertino later this month, and we can at that time give some consideration to how this might best be done. You have in the community, as you well know, a wealth of know-how and experience on which you can draw, to get the community off to a really good start.

I want to thank you for agreeing to assume this responsibility again, and assure you of my support and prayerful remembrance.

Sincerely,

Reverend Joseph Stefanelli, S. M.

cc: Community Bulletin Board

000312

C O P Y

2 April 1977

Reverend Thomas Havel, S. M.
Marianist Community
14830 South Van Ness Avenue
Gardena, California 90249

Dear Tom,

As I had indicated to you at the time Ed and I were visiting your community, I would like to follow up that visitation with a few personal reflections on the community situation as I see it. This is not, therefore, an "official" report, since it is not reviewed in Council; that "official" report is being made at the time of the Provincial Chapter.

In general, I found the community atmosphere very positive, people satisfied, and no one asking to move out! I believe you yourself have been an excellent positive force in the community, despite the necessity of frequent absences because of your work. Members of the community understand why you cannot be there, and are very grateful that you manifest such intense community spirit when you are present. They have regrets, but no criticisms, about your not being able to be more present than you are.

They also appreciate very much your concern for each one, and the time you take to talk to them individually. This is very encouraging, and in some cases has proved a real challenge to a more serious preoccupation with the religious life.

From what I understand, despite some misconceptions on my part at first, your community meetings are well-attended generally, and given to serious considerations. I would encourage this to continue, asking the community to attempt a more profound investigation of certain issues that need to be surfaced: the nature of community prayer life, priorities concerning involvement in the school, attitudes to be taken as Christians and religious on the question of the Teachers' Strike (and the strikers themselves).

000313

C O P Y

Reverend Thomas Havel, S.M.
2 April 1977
Page 2

As you know, and is evident to all, the participation of some members in the communal prayer life leaves much to be desired. The community must continue to deal with this phenomenon, not only in an all-too-easy judgmental sense, but in trying to understand the basic positions of each, and what might be done to help each religious "stretch" a bit to meet the positions of others and to enable the community to find a common position that, while not being merely the lowest common denominator, will enable all to participate more fully in the community prayer life. Perhaps this one issue could occupy a prolonged period of time -- two or three meetings in a row, a week-end "renewal" period, a periodic retreat...

The Offices, from what I could gather, are functioning fairly well, and I commend you and the Heads of the Offices for this. There does seem to be need to share explicitly more about the various apostolates (including studies) in which people are involved, to see how they might be better supported by the community, and to create the atmosphere which will allow a certain amount of non-threatening challenge to take place.

I would like to commend the high school personnel in particular for their evident dedication to the school, and to their interest in that work. As always, a balance must continually be sought between the commitments to the apostolic works, and the responsibilities to the development of community life. This, too, might provide material for some prolonged community consideration, especially as the number of religious available diminishes. Alternative methods of presence in the work should be explored, to effect if possible greater influence with fewer religious -- not easy, I admit, but desirable!

I want to thank you, and the entire community, for the evident spirit of hospitality and friendliness in the house, and for your graciousness to us in particular. May the approaching Easter Season bring much peace and joy to all.

Sincerely,

Reverend Joseph Stefanelli, S. M.

000314

cc: Community Bulletin Board

C O P Y

16 February 1977

Reverend Thomas Havel, S. M.
Reverend Frank Campanella, S. M.
Marianist Communities
California

Dear Tom and Frank,

I am writing this as a joint letter to the two of you, since you will have to collaborate on the matter it presents! As you know, Ed and I have scheduled our southland visitation for March, and I would like at this time to work out some of the details.

Ed will be flying in from the East (Interprovincial Formation Meeting), and I should be driving down from Cupertino, on March 13, Sunday. We plan to return to Cupertino, Saturday, March 26. During the interim, we would like to visit each of your communities, preferably together, and hold three meetings with the community and one with the Council.

The topics of the three community meetings will be: 1) Provincial Administration Goals and Objectives; 2) Overview of the Province; 3) Local concerns and feedback on the visitation. I therefore ask the two of you to work out the details of scheduling these various meetings in ways that are most convenient for you and your community calendars. If Ed and I have to commute back and forth, we will do so. However, generally, we hope to spend at least 5-6 days in each community.

During the course of this visitation, I would also like to see each religious in a personal interview. The scheduling of these interviews will, of course, depend on the calendar of meetings, and I will draw up the interview schedule after I arrive. I would be grateful if I could have the visitation calendar by March 1, when I will be back in Cupertino.

Sincerely,

Reverend Joseph Stefanelli, S. M.

000315

C O P Y

October 12, 1976

Reverend Thomas Havel, S.M.
Marianist Community
14830 South Van Ness Avenue
Gardena, California 90249

Dear Tom,

Greetings from Hawaii! This is just a follow-up to some of the items discussed at the Directors' Workshop about our "joint visitation" to your community and to Canoga Park in December.

Ed and I plan to drive down on Saturday, December 4, possibly stopping in Santa Barbara to see Joe Aspell, unless Joe can get to Canoga Park while we are there. We plan to return north December 19 or 20.

During that time, as you know, we would like to speak to your community about the General Chapter (a follow up to what Ed and Dave will have already presented in November), and about the relations of the Provincial Administration with the local community that is, two input sessions. We would also like to have two other sessions with the whole community, to provide opportunity for questions and discussions on those two topics (or any others the Brothers might want to raise). We would also plan a meeting (at least one, more if desirable) with the Community Council to discuss local concerns and ways in which the Provincial Administration might be of service to your Council, your Office, or the community itself.

Since we hope to have a similar schedule with the Canoga Park community during that same period of time, I ask that you get in touch with Father Campanella to work out the calendars of each community in such a way as to avoid conflicts in scheduling. We will be at the disposal of the communities, and will make no other plans until we get the schedules you have drawn up. Ed will also want to see each religious individually, but that schedule can be

000316

C O P Y

Reverend Thomas Havel, S. M.

October 12, 1976

Page 2

worked around the meetings easily enough. While we would of course like to keep the commuting between Gardena and Canoga Park to a minimum, that is not the prime consideration. Schedule the meetings at the times that are most convenient for the two communities, and we will adapt accordingly. As I indicated at the Directors' Workshop, these meetings with the Community are not necessarily in addition to the regular events on the community calendar; they might replace some other community function or spiritual exercise.

I would appreciate it if you and Frank could get your respective (or a joint) schedule to me by mid-November, so we can make our own further plans. We intend to spend most of our time in either community, so as to get a feel for the community life and spirit, and also to be available for the many informal contacts that are sometimes more useful than the formal ones. When you send the schedules, please also indicate which local concerns have surfaced from prior community discussions and which you and the community would like to have us address when we come.

My greetings to all the Brothers, and best wishes for a growthful year.

Sincerely,

Reverend Joseph Stefanelli, S. M.

000317

C O P Y

June 13, 1976

Rev. Thomas Havel, S.M.
Marianist Community
14830 So. Van Ness Ave.
Gardena, CA. 90249

Dear Fr. Tom:

On behalf of Fr. Stefanelli and his Council I wish to express our gratitude and good wishes at your acceptance of the Acting Directorship of the Gardena Community.

I'm sure Fr. Joe mentioned the community consultations showed a great deal of respect for your leadership qualities and for all the time and interest you've shown with your involvement in community life and functions. Welcome to the life of administrators!

Although your term is only one year, and that year usually begins August 15, we would like you to begin June 15 since Bro. Haster is in San Francisco. If you find this difficult due to your summer program we'll understand. For this reason we won't mention any date in PAC and we'll let you break the news to your community in your own fashion.

Be assured of our support and prayers. God bless

Yours in Christ,



Bro. Robert Hoppe, S.M.
Acting Provincial

000318

C O P Y

May 7, 1976

Reverend Thomas Havel, S.M.
Marianist Community
14830 South Van Ness Avenue
Gardena, California 90249

Dear Tom,

In the press of a busy schedule, I am sending you this formal notification that your request for admission to a renewal of temporary vows was reviewed in Council this week. I am happy to inform you that the Council, after studying the consultations received from your fellow religious, has recommended that you be granted this favor you ask. I therefore authorize you to renew your profession of temporary vows, for a period of one year, at the time of your annual retreat.

When I see you personally, I will share with you the major reflections of your fellow Brothers, the positive points they find in you which lead them to recommend your renewal of vows, and the negative points which some of them see as counter-indications of a true Marianist vocation. I am sure that by now most of these comments are known to you, and I encourage you to give them all (positive and negative) your serious attention in order to prepare yourself better for the donation implied in the religious profession. Be assured of my personal best wishes and my prayers, as well as those of the other members of the Provincial Administration, that you may each day correspond more generously and lovingly to the grace God offers you.

Sincerely,

Reverend Joseph Stefanelli, S.M.

cc: Brother John Haster, S.M.

60 319

C O P Y

November 19, 1975

Reverend Thomas Havel, S.M.
Marianist Community
14830 South Van Ness Avenue
Gardena, California 90249

Dear Tom,

Enclosed is an Indult from the Holy See for you to practice medicine. When I was in Rome in September, Father Miguel Sanchez-Vega insisted we needed one -- so here it is. Isn't it nice to know you are "legitimate" in the exercise of your professional duties?

I hope all is going well with you, and that you are getting a little rest from time to time. I will be coming south in January and will see you then.

Sincerely,

Reverend Joseph Stefanelli, S.M.

enc.

000320



DEPARTMENT OF EDUCATION
 DIVISION OF GRADUATE EDUCATION
 PERSONNEL SERVICES
 Director
 Elsie C. Markedakis
 Assistant Director

Sept. 30, 1975

Thomas E. Havel, M.D.
 14830 S. Van Ness Avenue
 Gardena, CA 90249

Dear Dr. Havel:

I am pleased to inform you that we will be able to offer you an appointment as a Postgraduate Physician Year II in Psychiatry (First Year Resident) at the Los Angeles County - USC Medical Center. This appointment currently carries the following monthly stipend:

- Postgraduate Physician Year II (1st Year): \$1376.
- Postgraduate Physician Year III (2nd Year): \$1491.
- Postgraduate Physician Year IV (3rd Year): \$1607.

There is a Southern California Agreement that residency programs will not demand an acceptance less than 14 days from the date of offer. However, if you know earlier that you want the appointment I would appreciate hearing from you. Similarly, in the event that you do not want the appointment I would greatly appreciate notification at your earliest convenience so that the position can be offered to someone on the alternate list. In the event that you decide to accept our residency, be sure that the enclosed agreement is returned in the enclosed envelope by October 15, 1975.

The entire Department joins me in our hope that you will be with us next year. With best regards, I am

Sincerely,

Sherwyn M. Woods, M.D.
 Professor

SMW:kt
 Enc.

000321

C O P Y

May 18, 1975

Reverend Thomas Havel, S.M.
3729 "T" Street, N.W.
Washington, D.C. 20007

Dear Tom,

Your request to renew temporary vows as a Marianist was reviewed in Council. I am happy to inform you that you are hereby admitted to a renewal of vows for one year. While we are not able to hold a regular "consultation" for this renewal, the evaluations held in the Gardena community earlier in the year were of great help. At the time of the retreat in Honolulu, I will be happy to review with you the comments and suggestion offered by your fellow-Brothers. I am sure you will find it helpful for your own Marianist life, to know how your Brothers see you, what qualities they discern, and also what areas of improvement.

I am sure these days are full ones for you as you prepare for graduation. My personal congratulation, Tom, and prayers. It will be good to have you back within the confines of the Pacific Province soon.

Sincerely,

Reverend Joseph Stefanelli, S.M.

000322

C O P Y

May 12, 1975

Reverend Thomas Havel, S.M.
3729 "T" Street, N.W.
Washington, D.C. 20007

Dear Tom,

Thanks for your letter of May 1, and the news. Congratulations on your graduation, and on being homilist for the occasion. I suspect it is not too often that a graduating Doctor is also a priest; are you perhaps the first at Gerogetown?

I leave May 10 for the UD workshop/retreat on Marianist Purposes in Higher Education. If it were not for having to return for Rodney's ordination, I would like to come to Washington for your graduation -- however, bilocation is not yet a component part of being Provincial. . . I should be here in the Cupertino area the last two weeks of May, and will be going to Honolulu for the retreat, so I am sure we will have occasion to talk over your plans for the future.

Best wishes, prayers.

Sincerely,

Reverend Joseph Stefanelli, S.M.

000323

THE MARIANISTS

14830 SOUTH VAN NESS AVENUE
GARDENA, CALIFORNIA 90249

October 28, 1974

Dear Harry and Joe,

Concerning my plans (immediate and distant), I will list the upcoming events and you can use whatever you wish.

I will be in California until February 23, 1975.
From October 14 thru Nov. 8th, I am doing a four week elective in Cardiology at LAC-USC Medical Center.
From Nov 8th until Nov 17th, I will be interviewing with the different Hospitals to which I am applying for internship and residency.
All my applications are for Straight Medical Internship, i.e. they are the first year of a three year Residency in Internal Medicine, the speciality I think I help the most people with.

The Hospitals I am applying to are: San Francisco General Hospital, Kaiser in San Francisco and in San Jose, Santa Clara Valley Medical Center in San Jose, St. Mary's in Long Beach, Long Beach Memorial ("the Hospital of X-presidents"), LAC-USC Medical Center in L.A., Harbor General in Torrance, VA Hospitals in Westwood and San Fernando Valley, Orange County General Hospital, Riverside General Hospital.
(All are University affiliated programs.)

Then from Nov 18 through December 13th, I have an elective in Physical Medicine at Harbor General Hospital in Torrance,
From Dec 16th thru Jan 10, I return to LAC-USC Medical Center for an elective in Dermatology.

Then I have 6 weeks of vacation. One week will be for retreat. Two weeks vacation, two weeks to show "My little old ladies" around California. and a week to drive back to Wash.

Once back in D.C. I have 4 wks of Emergency Medicine, 4 wks. of Radiology and 6 wks. of Surgery. Then I get my M.D. on May 25, 1975.

My Internship will begin on July 1, 1975.

During my travels through the state, while I am visiting most of the communities in California, I want to take the time both formally and informally to explain what I am doing to the communities and to get their feedback.

This is "where it's at" for me at this time. You can edit this material as you wish. If I can ~~earr~~ clarify anything please let me know.

In Him,

000324

Tom. *Harold*

291437 MOONEY BERNARD
DR ELLISON CATH 2509
6353 64TH AV RIVERDALE MD
9/29/74 M13 P/MED 136424

PROGRESS NOTES

| DATE | |
|------|---|
| | 10/3/74 |
| | Dear Joe, |
| | I leave Sat for Calif. I'm looking forward to being back in the Province again. |
| | I received a letter from Jack McNeil in which he told me about his plans & enclosed a copy of the letter he sent to you. I feel bad about it - not only because he is leaving; but also, because, I feel after reading his letters, that <u>he</u> doesn't know the <u>real</u> reasons why he is leaving. I would like to share more of this with you when I see you next. |
| | The visit to Dave Schayler was great. I hadn't spoken much to him before; but so this was a great chance to know him better. I think we to can have high expectations for the P. A. what is the kind of men we have in it. |
| | Enclosed is my expense account. It is high this month & I be glad to give more of an explanation if necessary. I expect a \$2,500 <u>ee</u> loan to come through any day now. |
| | In X t Tom. 000325 |

C O P Y

September 16, 1974

Dr. Thomas E. Havel, M.D.
937 12th Street, Apt. 202
Santa Monica, CA 90403

Dear Dr. Havel,

Thank you for your kind note and the check for \$3,000 toward our Educational Fund. I assure you of my personal gratitude and the appreciation of my Administration for this gift.

I just wrote to Tom a few days ago. Hopefully he will be able to come out this way soon, and I am sure that you and the family will find that considerably more satisfactory than his being in Washington. I was able to visit him there last spring, and we had a good long talk about the future of health care service in the Society of Mary. Your son may turn out to be a real pioneer!

My greetings to Mrs. Havel. I trust you are both in good health.

Gratefully,

Rev. Joseph Stefanelli, S.M.
Provincial Superior

000326

C O P Y

September 9, 1974

Reverend Thomas Havel, S. M.
3729 "T" Street, N. W.
Washington, D. C. 20007

Dear Tom,

John Haster was here, of course, for the Directors' Meeting, and told me that you expect to come to the Coast early October. I think that is wonderful, and I say Welcome Back! I am certainly glad you were able to find hospitals in the LA area where you can work.

Perhaps by the time you get this letter, you will already have seen Father Schuyler. I shall not try to come to Baltimore on my trip East next week, because of a very tight time schedule. But I certainly will be seeing you in Gardena.

Your being in Gardena should give you a number of occasions to see Art Gomez and to compare notes on future health care plans. Ray Mooney was here briefly last week. He is scouting around for openings for Physician's Assistant next year after he finishes his studies. I suggested the possibility of Walla Walla, where there are several large hospitals and not too many doctors. We'll see what develops.

000327

C O P Y

Reverend Thomas Havel, S. M.
September 9, 1974
Page 2

I hope your two "mothers superior" do come out to the Coast -- and I promise not to ask them too many scrutinizing questions about your behavior. Best wishes for your studies, and see you in a couple of months.

Sincerely,

Reverend Joseph Stefanelli, S. M.

P.S. Just got yours of the 3rd. Santa Clara Valley Medical has a very good reputation. A whole wing for paraplegics, run by one - also a very good burn unit. I have visited there a number of times and been much impressed. Not a very professional evaluation, of course.

000338

C O P Y

July 29, 1974

Reverend Thomas Havel, S.M.
3729 T Street
Washington, D.C. 20007

Dear Tom,

Just a note to acknowledge your letter of July 10. It was good to hear from you, and I was happy to learn that you were able to make a good portion of the retreat. I am glad, too, that you and Ray Mooney were able to compare notes on the future health apostolate. We will have much to discuss and plan, and I hope you will be coming to California soon.

I appreciate and understand your reluctance to participate in the consultation for Assistant Provincial. We are still awaiting official news on the appointment. Father Tutas is due in here tomorrow. Maybe something will materialize soon. Unfortunately, Roger is already in Europe and will not be back for a couple of weeks. He was ready to come at a moment's notice to brief the new man on many phases of the job. As you know, he is working for the Foreign Study League, and living (when he is home) in Los Gatos, so he is not far away--either in geography or in interest.

I checked with the novitiate about your parka. Kevin says it is there, and they will hold it for you unless you want them to send it your way. I thought it best to wait until you know for certain where you will be for the winter. I hope it will be California.

Greetings from all of us out here. I passed you by in flying directly from New York to San Francisco last Saturday, returning from the Over-50 Program.

Sincerely,

Reverend Joseph Stefanelli, S.M.

000329

+

SEP - 9 ANS'D

Sept 3, 1974

Dear Joe,

I hope all is going well to you. I have a breather for 3 wks working in the Pediatric out patient Dept. The hours are human (8-5 x 5 d/wk) + the kids are great fun to work with.

I am trying to get some applications off for internships during the coming wks. One of the hospitals that I am applying for is Santa Clara Medical Center in San Jose. If you know anything about it, let me know. I don't know anything about it; I choose it because it was near one of our communities which is the prime motive in all my applications.

In about 5 wks I'll be in Calif.. I already wrote to John Haster about putting me up at Serra for most of the time. As of yet, I haven't had a reply; but I'm optimistic about staying there.

All my elective time is now scheduled; so I'll be able to stay the whole 4 1/2 months in Calif.

Enclosed is my expense account for August. Please forward it to Br. Charles.

I'm sure that I'll be in your neck of the woods for interviews and for a retreat.. Until then keep me in your prayers.

In Xt,
Tom

000330

JUL 29 ANS'D

PROGRESS NOTES

+

July 10, 1974

| DATE | |
|------|--|
| | Dear Joe, |
| | Enclosed please find my expense account for June '74. Please forward it to Br. Charles. Also enclosed is a letter from Dr. Lefevre. I had an exam last February for hypertension. If our insurance covers the laboratory expenses, could Br. Charles forward to him the proper forms? If our insurance doesn't cover the exam, please have him prep Dr. Lefevre a note to that effect. |
| | I received the \$3000.00 from the Province. As of now, I still haven't received information on my student loan. There probably won't be any until Sept. |
| | Roy Mooney was in DC 2 wks ago. We had a very good talk. And we share many of the same goals in regards to our sharing a health care apostolate. However, he will have to find an intermediate work until I finish my studies. |
| | Your thoughts about an inter-provincial health-care apostolate, might receive some impetus when John Mc Guth told me about a M.D. who made inquiries about joining their Province. He said that he would keep me informed; but so far no word. 000331 |
| | My "retreat" worked out better than hoped! The location was changed at the last moment. And it was held at a retreat house about 20 min |

PROGRESS NOTES

| DATE | |
|------|---|
| | <p>drive from Georgetown. So, I not only made the last 2 days, but I also went out each evening for the evening vesper, dinner & the night conference.</p> |
| | <p>Please thank John Bolin for his kind note. I hope he will enjoy his new role in S. F.</p> |
| | <p>I did not forward my recommendation for Asst. Provincial because I didn't feel knowledgeable enough about the people being considered & the present needs of the province. I hope you will understand my reluctance to participate at this time.</p> |
| | <p>It was a real shock to hear about Roger. But my prayers & best wishes go with him.</p> |
| | <p>There is still no definite information about my elective courses in Calif. for Oct → Feb. But when they are firmed up. I'll drop you a note. I'll probably stay at Serra if all goes well.</p> |
| | <p>Please give my regards to all at the provincialate.</p> |
| | <p style="text-align: center;">In Xt, Tom</p> |
| | <p>P.S. Please ask Charlie Oyabou if he has seen a large blue parka at the Novitates. I think I might have left it there when I visited last Feb.</p> |

C O P Y

May 13, 1974

Reverend Thomas Havel, S. M.
3729 T Street, N. W.
Washington, D. C. 20007

Dear Tom,

It was certainly good of you to come to Baltimore to see me, and I am glad we had a few moments to chat about your studies and your future. Your application for renewal of vows was processed today by the Provincial Council, and I am happy to admit you to a renewal of vows for one year. I will delegate Father John Mulligan (or whomever he names) to receive your vows at the end of your retreat with the Brothers of the New York Province.

I am sure you will spend the few hours you can spare for a retreat, in serious prayer and reflection, and so prepare yourself for a renewal of vows that will reflect a deepening of convictions and a growth in generosity. Be assured that your Brothers of the Pacific Province are with you, in thought, and in prayer. I regret that none of us can be there to share physically in your profession.

May God continue to bless you, Tom, and may you grow stronger in your Marianist vocation.

Sincerely,

Reverend Joseph Stefanelli, S. M.

000332

C O P Y

April 8, 1974

Thomas E. Havel, M.D.
937-12th Street, Apt. 202
Santa Monica, CA 90402

Dear Dr. Havel,

Tom has just written me to tell me of your projected trip to Europe. I am writing to Father Tutas at our general headquarters in Rome to advise him of your arrival. Please get in touch with him; he will be happy to be of whatever assistance he can to make your stay enjoyable and profitable.

Our Rome address is Via Latina 22. The phone is 75 75 892.

My prayers and best wishes for your trip.

Sincerely,

Reverend Joseph Stefanelli, S. M.

000333

C O P Y

April 8, 1974

Reverend Thomas Havel, S.M.
3729 T Street, N.W.
Washington, D.C. 20007

Dear Tom,

Just a quick reply to your letter, as the Chapter gets under way. I have sent a note to your Dad about getting in touch with Father Tutas in Rome; however, your Dad may not get in before leaving. I will write to Father Tutas also, and ask him to call the hotel where your folks will be staying.

I am looking forward to seeing you in Baltimore. I hope it will not inconvenience your schedule too much.

Sincerely,

Father Joseph Stefanelli, S.M.

000334

APR 8 ANSD

April 3, 1974

| DATE | <p>Dear Joe,</p> |
|------|---|
| | <p>I thank you for your letter of the 15th. It will be good to see you when you get to Baltimore. Unfortunately, I will begin working at D.C. General Hospital on April 21st; so I don't have my schedule for that week-end yet. However I will call before I drive up to Baltimore.</p> |
| | <p>Right now I am doing my rotation on Internal Medicine. It is the busiest of all the services; so I don't have much free time. It is interesting but very demanding. It will be good to talk about something other than medicine.</p> |
| | <p>We do get 3 days off for Easter; and we do I plan on going up to Baltimore for Good Friday, Holy Saturday + Easter. Hopefully, I'll get away early on Holy Thursday.</p> |
| | <p>My parents are leaving for Europe next week. I know that it is rather late; but could you send my parents a letter of introduction to Fr. Tutas. They will be in Rome April 17-24 at the Quirinale Hotel. (First they plan on spending Holy Week in Spain).</p> <p style="text-align: center;">Have a Holy Easter,</p> <p style="text-align: right;">Dom</p> |

000335

C O P Y

December 6, 1973

Dr. Thomas E. Havel
937-12th Street, Apt. 202
Santa Monica, CA 90403

Dear Dr. Havel,

As you know, I was away for some meetings in Spain when your letter and check for \$2,000 arrived here. I want to take the occasion to express my personal gratitude to you for this, and for your many other manifestations of generosity in our regard. And I thank you also for your expression of best wishes for me in my functions as Provincial; I ask for a continued remembrance in your prayers.

The future contribution of the Province to the medical field seems to be solidifying itself. In addition to Tom, we have a young Brother preparing himself as a Physician's Assistant, another Brother presently working with the aged and infirm in a parish, a Brother working in a mission hospital in Africa, and a candidate who has had considerable experience in hospital administration. Perhaps Father Clemens' dream of a "medical team" will be realized. I am sure we can count on your advice when we get a little closer to the realizations.

My best wishes for you and the family, especially during this Christmas season.

Gratefully,

Reverend Joseph Stefanelli, S. M.
Provincial Superior

000336

C O P Y

October 16, 1973

Reverend Thomas Havel, S.M.
3729 "T" Street, N.W.
Washington, D.C. 20007

Dear Tom,

Thanks for your letter of 29 September. I passed on your financial report to Brother Miller. I'm glad that you find the surgery rotation program interesting - you have to have an intense interest to keep up those hours. I know the hospital from my old C.U. days.

Glad to hear you get up to Baltimore. I know John Mulligan is always glad to see you. Do see Joe Yax - he always appreciates company from Pacific Province people. He is fearful of being forgotten or no longer accepted. Joe Davis will be interesting to talk with - I guess you know his position with the Black Catholic Movement. No pun intended but he has become a colorful if not controversial spokesman.

I also received a letter from Jack McNeil. Apparently he now resides at the University Catholic Center. I think this is much better for Jack although it sounds like he has been on the road rather frequently.

I mentioned hearing from you at our Provincial Council meeting last - so be assured of greetings from all on the Council.

000337

C O P Y

Reverend Thomas Havel, S.M.
October 16, 1973
Page 2

It will be good to see you in January. Take care and
thanks for the letter. Good luck on your studies.
Keep us in your prayers. I hope your family is well.

Sincerely yours in J.M.J.,

Brother Roger D. Richter, S.M.

000338

Sept 29, '73

Dear Roger,

Presently I am on the Surgery Rotation at the D. C. V. A. Hospital. It is the most interesting service I have been on so far; but the hours are long 8:45 am to 6:30 pm, 5 1/2 days a week, and on duty every 6th night. The hospital is over by Catholic U. so it is a 20-30 min drive each way.

Weekend before last I went up to Baltimore. I stayed at the Provincial house. It was quiet & a good rest. Unfortunately I didn't see Joe Yap. But I will definitely make it a point to see him next time up.

Joe Davis (from Cincinnati) called last night. He saw my name in the New York province Personnel. We plan on getting together some time next week.

Jack McNeil dropped me a note. I don't know how much the cause of Physics is being advanced; but it sounds like he is having a ball.

Unfortunately, the cut rate fares to L.A. are being dropped before I come home; I'm sure to make it there anyway. But, if it is still O.K. for me to go to the islands, I'll need some help for that leg of the journey (La. - to Ha). We'll talk about it when I see you in Jan.

Give my regards to the rest of the brothers at the Provincials. (Thank Joe for his letter. I'm looking forward to talking to him in Jan.)

yours in Xt

Tom

000339

C O P Y

September 7, 1973

Reverend Thomas Havel
3729 T Street, N. W.
Washington, D. C. 20007

Dear Tom,

Thank you for your letter of the 29th and your best wishes. I am gradually getting into the job; by now I hope you have received PAC 1 giving you some ideas of our plans. The Provincial Council met for three days at the end of August, and I think we are off to a good start.

I will be looking forward to seeing you in January when you have a vacation. My own plans will not bring me into your area until after Easter. I am certainly interested in your plans for the future, and I, too, hope we can move into some form of health-care apostolate. And I am in agreement with you that such work should be community-based. That is in keeping with what I consider a prime factor in Father Chaminade's thought: not only the aspect of community support and mutual compensation for personal limitations, but also the notion that it is the community itself that attracts and draws men to God. We will have much thinking and exploring to do when things get to the practical level, but I think we are looking in the right direction.

Be assured of my best wishes and prayers for you and your work; I am sure it is as difficult as it is interesting. Please keep me posted on your progress.

Sincerely,

Reverend Joseph Stefanelli, S. M.

000340

C O P Y

June 7, 1973

Reverend Thomas Havel, S.M.
3729 "T" Street
Washington, D.C. 20007

Dear Tom,

Thanks again for your steady stream of letters. It is always good to hear from you and find out the progress. I hope to see you very soon. I plan to be in Washington for a few days. I am scheduled to be there from the 30th of June through the 4th of July when I leave for New York. I am scheduled to stay at the Harrington Hotel in D.C. I never heard of the place but I suppose it is an okay hotel--American Express recommendation. It will be good to see you.

Two brief news items: John McCluskey is the new director of the Center community in Honolulu; Dick Britton of the Canoga Park Community. See you soon! Happy summer months.

Sincerely yours in J.M.J.,

Brother Roger D. Richter, S.M.

000341

C O P Y

May 11, 1973

Reverend Thomas E. Havel, S.M.
3729 "T" Street
Washington, D. C. 20007

Dear Tom,

Although I did write to you last week about your renewal of vows, I did want to answer your letter of March 8 in which you had made your request for a renewal of your temporary vows.

As you already realize the Provincial Council has approved of your request for a renewal of temporary vows for one year. My sincerest congratulations to you, Tom. We are very happy that you are a Marianist and are very proud of you. We realize as you do that since you are living outside a Marianist community you do not have the daily contacts with the Marianists which are so helpful to our religious life. However, we know that you do have the strength and responsibility to live your Marianist commitment even while outside community. We are looking forward to the day when you will have completed your studies and are working back in the Province and living in one of our Marianist communities. I know that you also are looking forward to this time.

We are very proud of the success you are having in your studies. I do hope and pray that all continues to go well with you. You are daily in our prayers and we are continually asking our Blessed Mother and the Holy Spirit to give you a deep spiritual life and a close union with Christ. Do remember to keep us in your continual prayers also.

Congratulations again, Tom, on your renewal of temporary vows. God bless you!

Sincerely yours in J. M. J. ,

Very Rev. Bertrand E. Clemens, S.M.

000342

C O P Y

May 4, 1973

Reverend Thomas Havel, S.M.
3729 "T" Street
Washington, D.C. 20007

Dear Tom,

Recently Brother Roger met with Father Mulligan to work on some papers they are to prepare for the next Provincials and Assistant Provincials' Meeting in St. Louis, Missouri. Father Mulligan mentioned that you made your annual retreat with some of the members of his Province, but did not renew your temporary vows at that time.

I have written to Father Mulligan in this same mail and told him that he could designate any priest to receive your vows. You may want to get in touch with Father Mulligan and find out whom he will delegate and when you could renew your vows. It might be well that you could renew them during Mass sometime after a day of recollection or when you are visiting one of the communities in the New York Province. Just work this out with Father Mulligan. I am enclosing the vow form for you, and you will need sign it and the date when you renew your temporary vows for one year. Also on this vow form should be the name of the priest who was delegated and did receive your vows. I believe this will take care of all that is necessary in this matter.

I hope all is going along well with you in your classes. By this time Brother Jack McNeil should be with you or have visited with you already. I am sure this will be good for both of you to be together for sometime.

I imagine Washington is very beautiful now with spring, and I hope you have a little time to enjoy all that nature offers after a long wet and cold winter.

00034/3

C O P Y

Reverend Thomas Havel, S.M.

Page 2

May 4, 1973

Brother Ed Mulvaney is again in the hospital and will be there for at least six months. They are constantly taking out flesh from these sores on his hip, and the doctor hopes that none of the sores are so deep that they go into the colon. For awhile, Brother Ed was quite depressed. He is in better psychological condition now. He has really gone through much suffering.

The new infirmary here on the Provincialate property is coming along quite well. Now that the rains are over, the construction crew is working on the sight, and next week they will pour the final pillars. Once the pillars are finished then they can begin framing the house. I am sure much work will be accomplished this summer, since there are a number of Working Brothers who have volunteered to work on the infirmary.

Again, you are ever in our thoughts and prayers. I hope that all is going along very well with your studies, and that you are really enjoying them. Keep us in your prayers also. God bless you!

Sincerely yours in J. M. J. ,

Very Rev. Bertrand E. Clemens, S.M.

Enclosure

000344

P.S. give Charlie the enclosed statement. Now that I have
the car + am moving, things will never be this good again!

May 4, 1973

Dear Reger,

WE had a very good retreat during Holy Week. It was held at Cardinal Gibbins High School in Baltimore. The retreat master, Fr. Campbell based it entirely on the Scriptures and esp. on the Scripture of Holy Week. Br. Howard Hughes did a great job with the liturgy and music. In fact the liturgies organized by John McGrath and Howard were what made the retreat so good. We also had a small prayer group which met every evening. Surprisingly it was the middle aged (and I include my self) that seemed to get the most from this type of prayer.

It was so good to be with people that didn't know the difference between a cathedral and a catheter (and what is more, they didn't care!!). It was good to be with real people.

John McGrath kidded me about the fact that I had finished my "official" retreat and yet had not renewed my vows. I told him that I guess that made me a free agent and I could sign on with any one now!!

Jack McNeil finally arrived last Tuesday. The trip was uneventful, except for the fact that he had to replace the tires and brakes in Oklahoma. He brought a very large trunk with him. In fact we had to take the door off the car to get it out. He flew out Wed. evening, for Paris. And he is to be on the job on Monday (May 7th).

He told me that Fr. Clemens had resigned. It is probably best for him. (it is a difficult job for any man); but the province and I, especially, will miss him as my "boss". I think that he had the ability to bring out the best in all of us.

In. X6. Tom

000345

C O P Y

April 17, 1973

Reverend Thomas Havel, S.M.
3729 "T" Street
Washington, D.C. 20007

Dear Tom,

Thanks very much for your recent letters. You are certainly faithful in keeping me abreast of what is happening in Washington, D.C. and with regard to your work at Georgetown and the Medical School. I am glad that you had the opportunity to have a visit with Brother Bill Bolts. It must have been refreshing to have a break from all of your classwork at Georgetown.

I just returned from Korea and from Japan. I found things to be in a good state in Korea with the school doing well in Mokpo and with a lot of activity taking place in Seoul including the presence of quite a considerable number of potential Marianists among the native Koreans. On the way back I had a chance to talk to Brother Ray Mooney. He had applied to well over 13 schools offering physician assistants programs and it looks as though he may possibly be chosen for a position at Mercy College in Detroit, Michigan. He had been rejected by at least four of the schools because of lack of space and the large number of applicants. I will let you know more about this as things develop.

Tonight we begin our Provincial Chapter and then I go into New Orleans for the NCEA meetings. I suppose by this time Brother Jack McNeil has made it to Washington, D.C. Give him my best regards if he is still there. May I wish you a very Happy and Blessed Easter season. Hello from all here in Cupertino.

000346

Sincerely yours in J.M.J.,

Brother Roger D. Richter, S.M.

C O P Y

February 15, 1973

Reverend Thomas Havel, S.M.
3729 "T" Street
Washington, D.C. 20007

Dear Tom,

I must acknowledge reception of both your note in January and the current one that just arrived the other day, dated February 6. I am glad that you are enthusiastic over this summer's priests' synod. I do hope that you will be able to participate in that particular meeting this summer if your studies will permit it.

I can imagine that you are very busy indeed with your work at Georgetown although certainly everything sounds as though it is going just great. We were all delighted that Jack McNeil finally had the opportunity to complete his doctoral studies at UCLA and will soon be on his way to Constance, Germany. We all pray for his success and that he will enjoy his stay there in Europe.

I don't see any difficulty with your planning on making the Holy Week retreat in Baltimore. Certainly I can understand the circumstances that might prevent your making a regular retreat in the Province during the summer. I have passed on the papers - the consultation for Assistant for Apostolic Action and the one for Brother Charles Miller.

000317

C O P Y

Reverend Thomas Havel, S.M.
February 15, 1973
Page 2

Father Clemens is going through another illness which the doctors at this time aren't sure of. To them it seems to have some of the elements of rheumatic fever but the tests have not yet come back from the hospital to complete the diagnosis. Please keep him in your prayers.

I had an opportunity to spend some time with Brother Ray Mooney, the student Brother at Kieffer who is interested in paramedical training. He is very intent on preparing himself to be a physician's assistant and work with you after you have completed your medical studies and in practice. Let me know what your thinking is on this. I would appreciate whatever insight you might have and in the meantime you might possibly write to Ray Mooney in case he doesn't communicate with you. I have encouraged him to write to you so that you know what his thinking is.

Best regards to you, Tom, for everyone here at the Provincial House.

Sincerely yours in J.M.J.,

Brother Roger D. Richter, S.M.

000348

February 12, 1973

Dr. and Mrs. Thomas E. Havel,
937-12th Street
Santa Monica, CA 90403

Dear Dr. and Mrs. Havel,

I wish to thank you sincerely for your check for \$2,000 given us as a gift for the Marianist Educational Fund. We appreciate very much this generous gift. As you mentioned in your letter, this gift will help us in solving problems that we are meeting.

I just wrote to Father Tom last week, for I had been visiting our community in Gardena, and the Brothers there had mentioned frequently how delighted they were with Father Tom when he was with them at Christmas time. The service and the understanding and friendship of Father Tom meant much to all the Brothers in Gardena. I wrote to Tom to thank him for this great concern for the Brothers.

I understand that this is a challenging semester for Tom in his studies. Next year most probably will not be as difficult as far as studies are concern, but I am sure that Father Tom will be busy with his work on the floors. We are very happy that Tom is with us and a member of the Society of Mary. We appreciate very much all that he means to us.

We hope that you are now in very good health again. We are concern about your health, and we keep you daily in our prayers and Mass.

Thank you again for your gift to us, and your continual remembrance of us. God bless you!

Sincerely yours in J. M. J.,

Very Rev. Bertrand E. Clemens, S. M.
Provincial Superior

CC0349

February 7, 1973

Reverend Thomas Havel, S.M.
3729 "T" Street
Washington, D.C. 20007

Dear Tom,

I have been thinking of you very much and wanting to write to you since I returned from Serra. Naturally, the Brothers were talking about you when I visited with them recently, because they appreciate very much having you with them during the Christmas holidays. Many thanks for being with the gang at Serra and taking such good care of them.

Also, I had some long talks with Jack McNeil, for when I arrived at Serra he was in bed with the London flu. I was delighted to learn that Jack has finished his doctorate studies and thesis and now can look forward in going to Constance, Germany. Naturally, he is relieved and all of us are very happy. I was overjoyed to learn that Jack will be driving your car back and have an opportunity to be with you in Washington before going over to Europe.

I understand that this is a real demanding year for you in your studies. I am sure you will be happy when this year is over and all the studies are behind you. I realize that next year the studies will not be as demanding, but your time will be taken up with your work on the hospital floor. I believe I remember, that you will be in Washington, D.C., all this next summer. I do hope you get a little chance for a break, and perhaps Jack McNeil can help you take such a break when he gets to Washington. We appreciate all you are doing, Tom, and certainly congratulate you on your progress that is outstanding and most successful. Thanks for everything.

000350

Reverend Thomas Havel, S.M.

Page 2

February 7, 1973

Roger tells me that he hears from you and we appreciate that you write us so regularly. You are in our prayers. I hope that mother and dad are in good health.

Sincerely yours in J. M. J. ,

Very Rev. Bertrand E. Clemens, S.M.

000351

December 9, 1972

Reverend Thomas Havel, S.M.
3729 "T" Street
Washington, D.C. 20007

Dear Tom,

Thanks for your letter of November 7. I passed on the account to Brother Miller, That \$200 necktie really sounds great. Everything is climbing in prices but I almost think the average monk never realizes it!

I am at Canoga Park on visitation right now and had a chance to get over to Gardena on last Sunday. They were on retreat so I got to see all of the community. All look well--even Joe Kindel is sporting a little fuzz under his nose these days! I talked with Jack McNeil. He is putting on weight which I think is primarily due to nerves. He really wants to get finished but his major professor seems to be in a little hurry to wind up the show. He went away for a month but was forced to return when he got a case of the gout. Jack feels this is God taking revenge on the man. All in all he still hopes to be in Germany very soon--within a month or so. Keep him in your prayers.

Glad to hear that all goes well with you and your studies even though they do keep you busy. If you get a chance during the holidays--do drop by Cupertino and say hello. I hope you have a nice Christmas vacation in the southland.

Sincerely yours in J. M. J. ,

Brother Roger D. Richter, S.M.

000352

October 25, 1972

Reverend Thomas Havel, S. M.
3729 "T" Street
Washington, D. C. 20007

Dear Tom,

Thanks very much for your letter of 3 October which was on my desk when I returned from NCEA Superintendents meetings in Omaha. I know that the check that you enclosed with your letter has been taken care of. You are carrying quite a load with 27 hours of class a week. But I know that you have high hopes, motivation and interest so I guess it makes it that much easier.

I gave Brother Charles Miller the expense account for September. I do hope that you have an opportunity of flying home this Christmas and visit with your family and the Brothers here in the homeland. I guess you have already received notification that both Brothers Leo Mulry and Richard Carter passed away in Honolulu within about a week of each other. Brother Leo, as you know, suffered from cancer and Brother Richard Carter died as a result of a heart condition.

Everyone here at the Provincial House sends you their best regards. By the way I did hear that Jack McNeil expects to complete his work at UCLA within the next two or three weeks and be on his way at last to Germany. I hope you have a white winter in Washington, D. C.

Sincerely yours in J. M. J. ,

Brother Roger D. Richter, S. M.

000353

September 11, 1972

Reverend Thomas Havel
3729 T Street
Washington, D. C. 20007

Dear Tom,

My belated congratulations upon your profession of vows in the Society of Mary. It is very good to have you with us through profession of vows. I hope that your dad is feeling better these days and that his recovery will be complete.

I had the occasion to spend a few days with Father Mulligan and he always wants to assure me that you are always welcome to the Provinciate in Baltimore or to the Gibbons community whenever you can make it to Baltimore.

Thanks for the report on what this semester holds for you at Georgetown. It sounds like quite a challenging lineup of courses. Good luck! The change in scholarship is not too great. I am sure you will keep Brother Charles informed of the necessary changes he should make in his budget figures. I hope to be seeing you sometime during the year. Please be assured of our continued remembrance of you in our prayers and thoughts.

Sincerely yours in J. M. J. ,

Brother Roger Richter, S. M.

CC-357

March 17, 1972

Reverend Thomas Havel
3729 T Street
Washington, D.C. 20007

Dear Tom,

In the Provincial Council meeting of March 13, 1972, we considered your request to take temporary vows in the Society of Mary. The Council unanimously approved your request. My sincerest congratulations to you, Tom!

I am sure that you will be very happy to receive this good news about your acceptance into the Society of Mary. Also, I assure you that we are very happy and privileged to have you become a member of the Society of Mary. I am sure that your studies are coming along well, and that fact along with the acceptance now into the Society is enabling you to attain the goal that you have set for yourself as a Marianist priest in medicine.

If it is still agreeable with you, we shall plan that you would take your first vows at the close of the annual retreat in Danville. That retreat extends from August 8 to the 13th. I would encourage you very much, Tom, as you look ahead now to your profession of vows that you continue to read and study, even if for brief periods, some of the writings of the Society of Mary. I am sure that such reading and study will enable you to even grow more deeply in your understanding and love of the Society of Mary.

I am looking forward to seeing you when Brother Roger and I are in Baltimore for the Provincials and Assistant Provincials' meeting. We shall be at the Provincialate in Baltimore of the New York Province from Friday, April 7 till Sunday, April 9 included. I do hope you will be able to get away from Washington long enough to visit with us in Baltimore.

000355

Reverend Thomas Havel

Page 2

March 17, 1972

Again, my sincerest congratulations to you, Tom, upon your acceptance into the Society of Mary. You are loved and admired by all the Marianists, we are privileged to have you join the Society of Mary. You are ever in my prayers. May God continue to bless you and your studies.

Sincerely yours in J. M. J. ,

Very Rev. Bertrand E. Clemens, S.M.
Provincial Superior

000356

November 3, 1971

Reverend Thomas Havel
3729-T Street, N. W.
Washington, D. C. 20007

Dear Tom,

Many thanks for your letter of October 26. I assure you it is always good to hear from you. I am happy that all is going well with you, but I certainly understand that you are very busy, and that your courses are keeping you extremely preoccupied. I am happy that all is going along so well with you.

I was sorry to hear that Dad is not too well. I certainly agree with you that it would be wise for you to visit him at Christmas. It is also very thoughtful of friends to invite you to their homes for Thanksgiving. It is also good to realize that the communities in the New York Province are so hospitable. I am grateful for this.

I am sure you will hear from Father Bolin, but he has been very busy of late. He was away from the Islands to attend the Seminary Board meeting and to have formation meetings over here. Now I know he will be busy catching up on classes with the novices, but I am sure he will write to you. We will certainly keep you on the mailing list, so you will be receiving all the materials going out from here. If you get a chance when you come to California for Christmas to come up this way, do not hesitate. It will be great seeing you and speaking with you. Do write when you get a chance and let us know how all is going along with you. We know you are busy, yet we are always happy to hear from you. You are in our prayers.

Sincerely yours in J. M. J. ,

Very Rev. Bertrand E. Clemens, S. M.

000357

Handed
10-17-71
BC

October 14, 1971

Father Thomas E. Havel, Jr.
3729 T Street NW
Washington, DC 2007

Dear Tom,

I am sending on to you a couple of enclosures that I think will be of interest.

The first is a copy of a letter from Father Ted Cassidy, director our our community in Chester, Pennsylvania. He is inviting all of us Marianists to a Halloween celebration at their community. As you will note from the letter, we hope that Father Tutas, our new superior general, will also be there for the occasion. You may have received such a letter directly from Father Ted, but I am sending on this one just to make sure that you know that you are included in this invitation. It would be good to let him know if you plan to attend.

I am also sending on a copy of the most recent issue of the MARIANIST RESOURCES documents. Along with it is a form requesting to be placed on the mailing list. In case you have not already received this same issue, I suggest that you return the request form to St. Louis so that you will be sure to receive subsequent copies.

Your name has been added to our mailing list for provincial bulletins, etc., and I hope that these have already been coming your way. Specifically, the workshop for our priests is coming up in November and we would certainly be delighted to have you join us on this occasion.

One of these days I hope to stop in on you in Washington, but don't hold your breath. In any case, you are always welcome here. I heard recently that you had been over to Cardinal Gibbons again and that is good to know.

Fraternally yours,

Very Rev. John D. Mulligan, SM
Provincial Superior

Enclosures

00358

SERVICES INCLUDE:

Individual Therapy
Group Therapy
Alcohol/Drug Counseling
Marriage Counseling
Pre-marital Evaluation
Psychological Testing
Spiritual Workshops
Professional Workshops
Retreat Weekends
Consultation to parishes and religious communities



For information call:
(415) 968-0689
All inquiries confidential

CARING FOR THE WHOLE PERSON

Living and working in a highly complex contemporary society creates emotional stress for church ministers as well as the persons they serve. Periodic mental health care has become an accepted part of everyday life in our present society.

Catholic spirituality ... and solid medical and psychiatric principles form the foundation of the Pastoral Services Center. Unique in its ability to treat the whole person, the center recognizes the role of God, both in the healing process and in the therapeutic experience.

The Pastoral Services Center at St. Joseph's College in Mountain View is a non-profit mental health clinic with a staff of experienced Catholic doctors, both religious and lay. The center specializes in counseling priests, religious men and women, and lay persons ministering in the church. Others are seen on request.

5935

Non-Profit Organization
U.S. Postage
PAID
Los Altos, CA
Permit No.

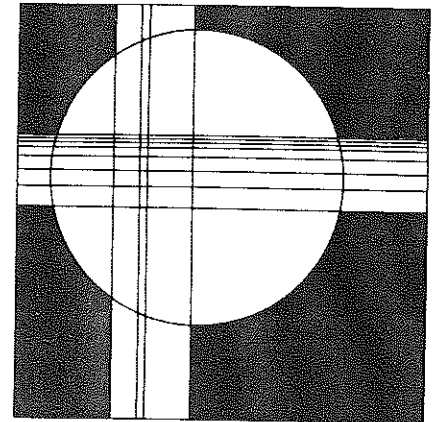

PASTORAL
SERVICES
CENTER

A comprehensive
Catholic mental health facility

000359

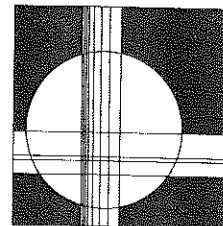

Pastoral Services Center
101 First Street #430
Los Altos, CA 94022

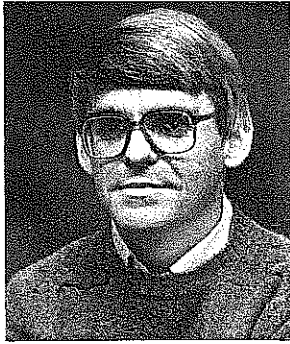

V. JAMES S. TUCKER, S.S., Ph.D.

Profession: Sulpician priest, clinical psychologist, marriage/family counselor, seminary instructor

Experience: Staff, McAuley Neuropsychiatric Institute; psychological testing; therapy for clergy, religious, married couples

Specialties: Stress disorders, depressive conditions, psychosexual disorders

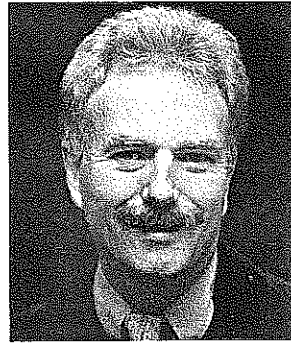

GERALD B. DOOHER, Ph.D.

Profession: Alcoholism/drug counselor, medical researcher, seminary instructor

Experience: Faculty appointments at Cornell University Medical College and Sloan-Kettering Institute; training of medical students and clinical psychologists

Specialties: Clergy, religious, and lay persons with chemical abuse problems and eating disorders; families and friends of alcoholic/drug abusers; pastoral counseling



LAWRENCE P. PERCELL, Ph.D.

Profession: Clinical psychologist, seminary instructor

Experience: Psychotherapy with adults and couples; psychological assessment and consultation

Specialties: Anxiety and depressive conditions, interpersonal conflict resolution

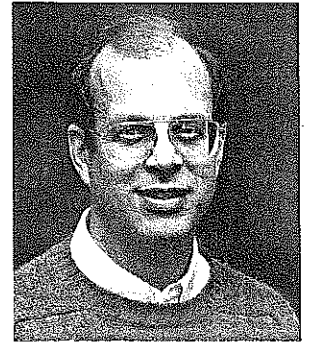

REV. THOMAS HAVEL, S.M., M.D.

Profession: Marianist priest, physician, psychiatrist

Experience: Medical director of psychiatric unit at El Camino Hospital; clinical instructor at Stanford University School of Medicine; consultant to religious psychotherapists; private practice in adult psychiatry

Specialties: General adult psychiatry, psychobiological psychiatry, especially affective disorders; short and long term psychotherapy



FRAN A. BITTER, R.N., Ph.D. (cand.)

Profession: Psychological assistant in clinical psychology

Experience: Marriage counseling, psychological testing, stress reduction, crisis intervention, mother of nine children

Specialties: Bioenergetics, Jungian psychotherapy, life transitions

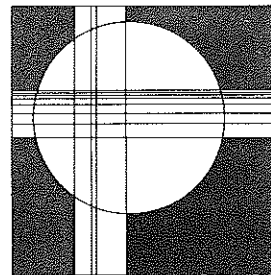

MICHAEL C. NERI, M.A., Ph.D.

Profession: Pastoral counselor, marriage/family counselor, seminary professor

Experience: Teaching, training, and counseling clergy, religious, and lay ministers; education and counseling to individuals, couples, and families

Specialties: Personal growth, relationships

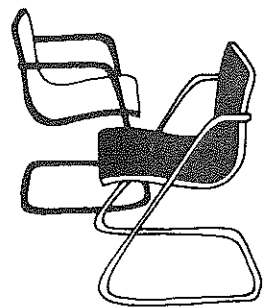

September 27, 1971

Reverend Thomas Havel
3729-T Street, N. W.
Washington, D. C. 20007

Dear Tom,

Many thanks for your letter of September 18. Brother Roger received your correct address and this is now in the new personnel, which you certainly have received by this time.

I am happy that you have found a suitable place to live. I do hope that all works out well in this new residence.

You certainly have a very heavy schedule. I am sure you will do well, but do not worry about your studies. You will continue to work as you have while at Loyola, and I know you will succeed. Have no concern. We will certainly keep you on our mailing list, and we will keep in touch with you. Do keep in touch with us, for we are always anxious to hear from you.

Brother Roger and I will be going to Serra and to Canoga for talks on the General Chapter. You probably have heard that Brother Ed Carey is in the hospital and recuperating from an operation. A part of his intestines was removed because of some scar tissue that was causing an obstruction. He seems to be doing quite well and is recuperating as quickly as can be expected.

Be assured that you are in our continual prayers and thoughts. Keep us in yours, and write when you get a chance. It is always good to hear from you.

Sincerely yours in J=M. J. ,

Very Rev. Bertrand E. Clemens, S.M.

000360

C
O
P
Y

September 13, 1971

Reverend Thomas E. Havel, S.M.
3729 T Street, NW
Washington D. C. 20007

Dear Tom,

Many thanks for your long letter of September 15 concerning your trip back to Washington D. C. and concerning your first impressions of Washington. I was very happy to read your letter and to hear that, despite difficulties, you arrived safely in Washington. Your experiences as you traveled across country must have been most interesting.

I am happy that you have finally found a suitable home near to the university. Brother Roger informed me that you called and gave us your new address. Many thanks. Father Mulligan, the Provincial of the New York Province, has asked for some information concerning you, so that he could publish it in a future newsletter to his province, so that the Brothers in the New York Province would be acquainted with you before they even meet you. I am very happy that you have found a warm welcome in the communities in the New York Province. I am sure you will experience this everywhere.

After you have gotten settled in your classes, do let us know how all goes with you in your studies. I do think it would be well if you kept in contact through letters with Father Bolin, so that he could direct you even at a distance concerning your program of study and reading regarding Marianist doctrine and heritage. As soon as we have received in print the declarations of the recent General Chapter, we shall make sure that you receive a copy. I am sure you will find the declarations very inspiring and helpful to your life style as a Marianist.

I am sending to you a thermofax copy of a letter I received from the Chancellor of the Archdiocese of Washington. By this time, I am sure you have received your faculties for the Archdiocese. If you have any difficulty in this regard, do not hesitate to write me.

000361

Reverend Thomas E. Havel, S.M.

Page 2

September 13, 1971

Be assured that you are in our thoughts and prayers. Brother Roger and I will be in Baltimore for the annual meeting of the Provincials and Assistant Provincials of North America after Easter. We certainly will be in touch with you while back there. You might want to keep this in mind as you plan your timetable for the year.

You are in our thoughts and prayers. Be assured that you, your life as a Marianist, and your successes in the study of school be everyday present in our petitions at Mass. God bless you.

Sincerely yours in J. M. J. ,

Reverend Bertrand E. Clemens, S.M.

Enclosure

000362



chaminade
preparatory

August 24, 1971

Very Reverend Bertrand Clemens, S.M.
Provincial of the Province of the Pacific
Marianist Provincial Residence
P.O. Box 987
Cupertino, California 95014

Dear Father:

Yesterday a unexpected but wonderful letter came in the mail. Georgetown University gave me a Tuition Grant of two thousand eighthundred dollars (\$2,000.00)!!!!!! The letter went on to say that the grant would be renewable each year if I would apply. This amount is for the full tuition; so that part of my expenses has been removed.

Also, in my last letter I forgot to ask for a "celebret" or a letter from you which will allow me to apply for faculties in the Archdiocese of Washington.

You had better send all correspondence to Gibbons High School, Baltimore, Md.; until I mail you my permanent address.

I am convinced that Christ has blessed me beyond anything I may deserve. And my whole life spent in service in His name will not even begin to express my gratitude.

Please keep me in your thoughts and in your prayers.

In Xt,

Tom

Thomas E. Havel

000353

The Marianists

7500 Chaminade Ave. • Canoga Park, Calif. 91304 • (213) 347-8300



chaminade
preparatory

August 19, 1971

Very Reverend Bertrand Clemens, S.M.
Provincial of the Province of the Pacific
Marianist Provincial Residence
P.O. Box 937
Cupertino, California 95014

Dear Father,

The following is my "State of Disorder Message". Please forgive the presentation! It will probably be disjointed and confusing.

As of today, I still do not have an acceptable place to stay in Washington. In June, I wrote to the Jesuits at Georgetown. They had no room; but recommended that I write the Vicar General of the Archdiocese of Washington. Bishop Herrmann, the Vicar General, suggested the White Fathers and the Carmelite Priory. The White Fathers' Residence is filled and I have not received a reply from the Carmelite Priory.

Ed Wong gave me several leads after I told him about my plans. Holy Child Academy and Ursuline Convent, which he recommended, both were unable to help. DeSales Hall (Seminary of the Oblates of St. Francis de Sales) did give me a place to stay. But the Seminary is in Hyattsville, Maryland. This is at the opposite end of Washington and commuting time would be about an hour, if I have a car, and longer if I use public transportation. This is too much time to take away from classes and studying, especially during my first year which has a very crowded schedule. Besides, one of the Medical Students, with whom I was corresponding to buy a microscope, wrote that traffic is very difficult and that parking, especially around Georgetown, is impossible. Also, the money which I originally planned to spend on a car (circa \$2,000.00) seems like too much of an expense, especially with all the other expenses that will be coming along. I did tentatively accept residence at DeSales Hall; so I will have a place to stay while looking for better lodging.

Fr. Roger suggested that I write the Head of Instruction for each of the Provinces and see if any other Marianist is going to Georgetown this year. So far I have had only one negative reply from Fr. Jansen!

Stone Ridge - School of the Sacred Heart, recommended by Holy Child Academy, offered me residence if I would teach eight hours of religion a week! I refused because of the conflict in schedule; but kept the lines open for future reference.

The Marianists

000364

7500 Chaminade Ave. • Canoga Park, Calif. 91304 • (213) 347-8300



Br. Hugh Hoganson, while he was back in New York, talked to the Redeemptorist Provincial. He suggested that I write Holy Redeemer College. They too were full; but suggested that I write the Theological College. I wrote there the first of this week; but the reply has not returned yet.

While I was at Santa Cruz, I spoke to Father Hughes about my problems in finding a place to stay. I asked his help; but there was no reply for several weeks. Then I wrote him; but still no reply. He called Br. Frank Fanger and I asked if anything had developed. He had been working on it; but he didn't have anything concrete. I will probably call him in a day or so to see if anything turned up.

All the above mentioned religious houses are from 15 to 30 minutes driving time away from Georgetown. They will all require some kind of transportation. Again, a medical student from Georgetown discouraged traveling any distance or even owning a car. I checked into a Catholic family in the area that offered rooms; but they had none. I also wrote to a family, named Goldblatt, whom I had met while ^{they were} visiting their daughter here in Calif. They have a home near Georgetown and at that time offered me a place to stay. I wrote to them yesterday to see if their offer is still open. I am sure that I could find an acceptable room near the Georgetown campus; but I will have to be back there and look around personally.

The big disadvantage to living near campus is that I would not be living in a religious community; and this is something that I personally do not favor. Its bad enough not having a Marianist community nearby; but no community at all is even worse. However, considering the disadvantages of commuting in Washington, the expense of buying a car, and especially my complete ignorance of the area, it might be better to go back and find a room near campus for the first semester or first year. I can make arrangements to say Mass at the University Chapel and maybe strike up a friendship with other religious living on campus or nearby. Maybe, after they see that people from California wear shoes and use a knife and fork at table, the Jesuits or another religious house near by might take me in. I would very much like to hear your thoughts on this matter. If you want more information, I can call or even come up and see you.

What do you want me to do about the car that I am using? It is owned by the Province but I pay the insurance on it. After September 1st my insurance will expire. It is a 1963 Chevy. I runs well but uses quite a bit of gas and oil. I has over 100,000 miles on it also. I will probably leave it at Serra and give the keys to Br. Ed. Carey.

I hope you have received a cheque from my father. He said that he had send you a three thousand dollar cheque about the first of July.

The Marianists

000365

7500 Chaminade Ave. • Canoga Park, Calif. 91304 • (213) 347-8300



chaminade
preparatory

Right now the papers on my Federally Insured Student Loan are being prepared. The Bank of America sets a limit of one thousand dollars rather than fifteen hundred dollars; so I will be five hundred dollars short in my outside income from that source. I would ask you to talk to Br. Charles Miller and have him send me a cheque to cover the following expenses:

| | |
|---|-------------------|
| Tuition for 1st semester | \$1,400.00 |
| Insurance for the year (health) | 31.00 |
| Partial board (2 meals per day for a semester) | 268.00 |
| Books (approximately) | 200.00 |
| Lab coats and gowns (approximately) | 75.00 |
| Microscope | 250.00 |
| Room (approximately \$75.00 per month for first five months) | 375.00 |
| Air plane ticket (American Airlines August 28th, 10:40 p.m. one way) | 155.00 |
| Pocket money and transportation fares laundry etc. \$35.00 per month for 5 months | 175.00 |
| | <u>\$ 2929.00</u> |

This seems like alot but some of the expenses will be eliminated for the second semester.

Since the loan will not come through for several weeks, I would like a cheque to cover the full amount. Then when I get the loan I will forward it to Brother Charles.

I plan on flying out August 28th in the evening. School starts September 8th so I will have a little over a week to get settled and find a place to stay. It will also give me a chance to go to Baltimore and meet the Marianist communities there.

Did you know that I was in the hospital about two weeks ago for three days? (St. John's Hospital in Santa Monica). If you didn't, you sure ~~would have~~ ^{will} when the bill arrives (approximately \$700.00)! That was for the hospital alone; the doctors donated their services! I was having these very severe head aches for about two weeks and they were afraid that I might have some kind of aneurysm. But it was an allergic histomine reaction. So now I am taking some medication to prevent the reaction. I don't know if I am covered by any policy that you have for Marianists. If there are any questions, I'll be glad to help. I figured that the \$31.00 for student health insurance is a cheap price to pay for the protection; that is why I included it in my expenses.

My stay at Santa Cruz was very rewarding. It was a pleasure to live with the Novices and Fr. Charlie. I also enjoyed the company of Fathers Tredtin and Fee; they even more than the reading brought me closer to the Marianist spirit and heritage.

The trips into the mountains with the groups from Chaminade were some of the best in many years. Both the trips and the boys



were well worth the effort. It was an especially fine group of boys that went on the trips this year.

I suppose that you have heard that Jack McNeil got appointed to the University of Constance in Germany for a two year post-doctoral fellowship. Now maybe he will finish his doctoral work.

Please convey my congratulations and promise of continual prayers to Steve Tutas. It will be hard to call him "Good Father"; but it will be a great privilege and honor to do so.

Also give my regards to all in the house; and, if you see my Novice Master, tell him that I am trying to stay on the straight and narrow. I was very impressed by the caliber of the novices under his guidance, especially the ones that made first vows last week.

Also please, give Roger all the gory details of my housing difficulties. He wrote to get my permanent address for the personal list. I probably won't have one for two more weeks; but as soon as I get it I will send it to him.

You will hear from me again, as soon as I get settled in Washington, if not sooner.

Yours in J.M.M.

Tom

Thomas Havel

P.S. Please have Brother Charles forward the cheque to cover my expenses as soon as possible. I have to pick up my ticket on Thursday of next week.

000367

The Marianists

7500 Chaminade Ave. • Canoga Park, Calif. 91304 • (213) 347-8300

May 3, 1971

Reverend Thomas Havel,
The Marianists
14830 South Van Ness Avenue
Gardena, CA 90249

Dear Father Havel:

This letter is to assure you that the Society of Mary (Marianists) approves and encourages you in your studies of medicine and psychiatry. The Society is very pleased that you will pursue these studies at Georgetown University, beginning in the fall school year of 1971.

There are two items we wish to bring to your attention as you begin your studies at Georgetown:

1. The Society of Mary will assist you financially, but only to the sum of \$1,500 to cover your room and board,
2. The Society is willing to assist you as mentioned above, provided that you are able to secure from sources outside the Society of Mary the funds to cover tuition, equipment, transportation, and other needs, other than room and board, which your schooling at Georgetown will entail.

Again we do approve of your studies and encourage them, but on the conditions given above.

Sincerely yours in J. M. J. ,

Very Rev. Bertrand E. Clemens, S.M.
Provincial Superior

000368

C
O
P
Y

May 3, 1971

Reverend Thomas Havel
The Marianists
14830 South Van Ness Avenue
Gardena, CA 90249

Dear Tom,

Enclosed with this letter is a formal letter which you requested that I write to you, so that you could submit it to the officials at Georgetown. I have tried to make it as formal and as pointed as possible, since this is what I thought you wanted me to do. If the letter is not satisfactory, do not hesitate to make changes and additions on the copy, return it to me, and I will make sure that you get the type of letter that you need and desire.

You also asked that I would put in writing your desire and intention to pay back to the Society of Mary the \$1,500 granted you annually for room and board while you are studying at Georgetown, before you should become a member of the Society of Mary, if eventually you would decide not to join the Society of Mary. I believe that this letter is sufficient as far as having this idea in writing. If there is anything that you would wish to have stated differently, do not hesitate to write to me.

I have tried, Tom, to put into writing in these two letters what I thought was your desire and our agreement after our conversation at Chaminade Prep. Do not hesitate to write and let me know if I have not understood something exactly as you thought or that we agreed.

It was wonderful seeing you again, and I appreciate very much your taking out time to come to Chaminade to talk to me. I always enjoy very much our visits together, and look forward to them.

Thanks, Tom, for all you are doing for the Marianists especially at Serra. This is more deeply appreciated than you can realize. We do hope with

000369

Reverend Thomas Havel

Page 2

May 3, 1971

God's grace and our Blessed Mother's very special intercession that in the not-to-distant future you will be a professed member of the Society of Mary. This is something that I personally and I know all the Brothers in the Province desire and pray for. May God bless you.

Sincerely yours in J. M. J. ,

Reverend Bertrand E. Clemens, S.M.

C
O
P
Y

000370

Fr. Clemens
Fr. Tates

28th of December 1970

Rev. Father Vincent Vasey, S.M.

Dear Father Vasey,

In its meeting of December 20th, 1970, the General Council considered the request of Father Bertrand Clemens, S.M., Provincial of the Pacific Province, to make application for an indult which would permit the Reverend Thomas E. Havel, Jr., priest of the Archdiocese of Los Angeles, to make his novitiate in the Society of Mary while pursuing secular studies on a full time basis.

Because of the qualities of Father Havel and because of the exceptional circumstances in his case it is advisable that he follow a special novitiate program as drawn up by Father John Bolin, Novice Master of the Pacific Province. The General Council endorses this arrangement. It is also advisable that the special program be undertaken while Father Havel is still engaged in his special secular studies. The General Council also endorses this arrangement under the following conditions:

- 1) That the duration of the novitiate be at least one full year.
- 2) That all vacation periods (Christmas, Easter, summer) be devoted full time to the novitiate program.
- 3) That at the end of one full year both the novice and the team of religious responsible for its fulfillment evaluate the program completed to that date. If the program has not been covered to the satisfaction of both the novice and the team, the novitiate should be prolonged (but not beyond a second full year) until the program is achieved to the satisfaction of the novice and the team.

The General Council's reasons for endorsing these arrangements are the following:

- 1) The course of studies that Father Havel is pursuing (medicine with a specialization in psychiatry) are of such a nature that a full year's interruption would make its resumption very difficult.
- 2) The close association of this priest with a Marianist community (living within it and acting as chaplain) for more than a year has already provided an exceptional head start for the proposed novitiate program.
- 3) The men who have lived with Father Havel are confident of his ability to undertake properly and successfully a novitiate program jointly with a program of secular studies.

With every best wish, I am,

Fraternally yours in J.M.J.,

000371

Thomas A. Stanley, S.M.
Assistant General

November 12, 1970

C
Reverend Vincent Vasey, S.M.
Curia Generalizia Marianisti
Via Latina 22
00179 Rome, Italy

Dear Father Vasey,

O
At this time, at the request of Father Clemens, I am writing to request that an applicant for admission to the Society of Mary, Father Thomas Havel, be dispensed from the required canonical novitiate and that the proposed program of preparation for the first profession of vows in the Society of Mary presented here be approved.

P
The Reverend Thomas E. Havel, Jr., was born October 12, 1937, in Blue Earth, Minnesota and was baptized there on October 27.

After attending schools in Minnesota, Nebraska and California, he entered the Los Angeles Archdiocesan Seminary, September 1955 and was ordained to the priesthood by James Cardinal McIntyre on May 3, 1963.

Y
After serving as Assistant Pastor in two parishes of the Archdiocese from 1963 through the summer of 1969, he was granted a leave of absence from the Archdiocese for the purpose of living in a Marianist community while considering the possibility of applying for admission to the Society of Mary.

The leave of absence was granted for one year beginning August 1, 1969. Under date of February 27, 1970, the Archbishop of Los Angeles stated "We are most willing to continue Father's leave of absence in order that you may receive him in your Novitiate, if you be so disposed."

From August, 1969, Father Havel has been living in our Marianist community in Gardena, California, sharing the priestly responsibilities for the community with Father Frank Campanella, S.M.

000372

Reverend Vincent Vasey, S.M.

Page 2

November 12, 1970

In a letter dated March 6, 1970, Father Havel formally requested admission to the Novitiate of the Society of Mary.

In reviewing Father Havel's application for admission, the Provincial Administration was impressed by the recommendations received from both the Archdiocese and the Gardena Marianist Community.

In the meeting of March 19, the Provincial Council approved Father Havel's request for admission to the Society of Mary. In his letter to Father Havel dated March 20, Father Clemens confirmed a proposal he had made previously, that the Province would work out a special novitiate program and present this to the Sacred Congregation of Religious in Rome for approval.

You will recall that I wrote you about this in my letter of April 14 which you answered on April 22, inviting me to present the proposed program. Later, when I was in Rome, you gave me further counsel on this.

Subsequently, Father Clemens was advised to request a dispensation from the novitiate for Father Havel. I am enclosing a copy of Father Clemens's letter to Father Havel.

I am also enclosing a copy of the proposed program prepared by Father Bolin.

Our reasons for requesting approval of this exceptional program are as follows:

1. Father's personal spiritual life is exceptional. He has achieved a human and Christian maturity superior to other candidates. The proposed program of preparation for the profession of vows is designed to emphasize an intensified growth in the religious life according to the Constitutions of the Society of Mary.
2. Father Havel is presently pursuing a course of studies in medicine with an eventual specialization in psychiatry. It would be very difficult for him to interrupt his studies in order to make a canonical novitiate. His age and university requirements make it highly advisable that he continue his course of studies without interruption.
3. It is our conviction that Father Havel will be able to master the points included in Father Bolin's proposed program by guided study.

000373

Reverend Vincent Vasey, S.M.

Page 3

November 12, 1970

4. We recognize that Father Havel has already received a definite Marianist orientation by participating in province retreats and living in a Marianist community, not simply passively but quite actively as a chaplain to the community.

We would like to have this program approved for the benefit of Father Havel himself, but also for the good of the Society of Mary. Such an approval would demonstrate that the Province is able to offer a program that is adequate and appropriate to the candidate.

You will know best how to present this effectively. If you need more information, I would be happy to give you further documentation or attempt to answer specific questions. I shall be in California until November 30 when I leave for the next meeting of the Preparatory Commission.

Thank you for your help in preparing this request.

Sincerely,

Reverend Stephen R. Tutas, S.M.

Enclosures

000374

C
O
P
Y

July 17, 1970

Reverend Thomas Havel
Junipero Serra High School
14830 South Van Ness Avenue
Gardena, CA 90249

Dear Tom,

When we spoke together during the time of the Azusa retreat, I mentioned to you that I would speak to the Major Superiors and canonists in Dayton when I met with them concerning your novitiate. I did have an opportunity to talk to several people. The Major Superiors were not able to help me in any way, since they did not have any similar situation concerning men entering their congregations at this time.

I did talk to Father Albin McCoy. He is presently the Provincial of the Franciscans in California and was president of the Canon Law Society of America at one time. He is quite a good canonist. I explained to him your situation, and his advice to me was that we should write to the Sacred Congregation asking for a dispensation from the novitiate for you. He said that we would have to come up with some kind of a program for you, which would naturally replace the novitiate, but that if we could get a dispensation from the novitiate as such, then we would not be held to the time limit which the novitiate demands and also to that obstacle which we have encountered of formal studies. Father Bolin has not arrived at the Provincial Administration yet. He is on his way back from St. Louis, Missouri, to Cupertino now. Father Tutas is in Rome working with the Preparatory Commission in preparation for the next summer General Chapter. When Father Tutas returns and when Father Bolin is here, I will work with them on preparing a letter which we shall submit to our Procurator General to the Sacred Congregation asking for this dispensation for you. Father McCoy thought that we would have success in getting a dispensation, because you have had seminary and are now an ordained priest. I will certainly keep in touch with

000375

Reverend Thomas Havel

Page 2

July 17, 1970

you as we progress along the way of petitioning this dispensation. I think Father McCoy's idea of asking for a dispensation from the novitiate in your case is a good one. However, we shall make sure that you would get time to study the Society of Mary as you desire, even though we can get a dispensation.

It was good seeing you at the retreat and talking with you. The Brothers at Serra are delighted with you and having you with them. Thanks for everything, Tom. You are in our prayers.

Sincerely yours in J. M. J. .

Father Bertrand E. Clemens, S. M.

C
O
P
Y

000376

For Discussion, revision, additions, subtractions, etc.

The following is a general description of the program of formation proposed for Fr. Thomas Havel in preparation for profession of vows in the Society of Mary:

Part One: General Plan

1. The program will begin with an OPENING RETREAT under the direction of the Director of Novices.
2. The main part of the formation program will center around a DIRECTED READING PROGRAM which will attempt to give both an overview of religious life in the Society of Mary, and an in-depth study of specific areas of concentration concerning the most important points of the overview.
3. Each month one of the members of the Formation Team will meet with Fr. Havel for a DIRECTION-DISCUSSION period treating the material being studied and Father's progress in preparing for profession.
4. Four times during the year there will be a QUARTERLY RETREAT for Father at the Novitiate, under the direction of the Director of Novices or one of the members of the Formation Team.
5. Finally, there will be a PRE-PROFESSION RETREAT of some length.

Part Two: Specific Areas of Reading-Study-Direction

The following areas will be treated in the overview and the in-depth treatments:

1. Marianist Documentation
2. History of the Society of Mary and of its Constitutions
3. Marianist Spirituality
4. Celibacy, Poverty, Obedience and Stability: Evangelical Living in the S.M.
5. Community of Life
6. Community of Worship
7. Community of Apostolic Action
8. Categories, Offices, Governmental Structures
9. Family of Mary
10. Theological-Scriptural-Pastoral Renewal

Part Three: Sources

There will be bibliographies provided for each area of study-discussion-direction, with core readings and supplemental readings taken from S.M. documentary sources and from recent books and periodicals.

Part Four: Formation Team

The direction of this formation program will be undertaken by a team composed of: Fr. John Solin, Director of Novices and Chairman of the Team; Fr. Hartmond Clemens, S.M.; Bro. Roger Richter, S.M.; Fr. Stephen Tates, S.M.; Fr. Joseph Stefanelli, S.M., and Bro. Edward Carey, S.M.

May 18, 1970

Reverend Thomas Havel
Serra High School
14830 South Van Ness Avenue
Gardena, CA 90249

Dear Tom,

Many thanks for your letter of May 10.

In view of the fact that it is not possible to interrupt your program of studies, my suggestion is that we follow through with the series of workshops and guided reading that I had originally prepared as a possible novitiate program. Evidently, the program cannot be authorized as a canonical novitiate program, but would serve as a progressive preparation for your formal entry into the Society of Mary.

We can discuss this in more detail when you come to Cupertino. I shall be away from the Provincialate from June 13-21, conducting a retreat. I hope to see you either before or after that date.

Be assured you are in my thoughts and prayers.

Sincerely,

Father Stephen R. Tutas, S.M.

000378

C
O
P
Y

April 29, 1970

Reverend Thomas Havel
Serra High School
14830 South Van Ness Avenue
Gardena, CA 90249

Dear Father Havel,

I have been in correspondence with our Procurator General about a proposed novitiate program for you.

We had worked out a program consisting of a series of workshops here at Cupertino during the summer and semester breaks. However, our Procurator General made several observations including the following:

1. Even when an exception is made for a single individual, the novitiate should last a full year.
2. Other studies leading to degrees of any kind are forbidden.

It would seem, then, that it will be necessary for you to interrupt your studies. The question is when you would prefer to do this.

I would like you to consider this and let me know your preference.

Sincerely,

Father Stephen R. Tutas, S. M.

000379

COPY

March 20, 1970

Reverend Thomas Havel
Junipero Serra High School
14830 South Van Ness Avenue
Gardena, CA 90249

Dear Tom,

I am very happy to write you that the Provincial Council in a meeting of March 19 accepted you into the novitiate of the Society of Mary. My sincerest congratulations, Tom.

As I mentioned to you in an earlier letter, if you were accepted into the novitiate, then we would write to the Sacred Congregation in Rome for a special novitiate program for you. In a previous letter to you, I outlined in general what might be such a program. As soon as we have been able to work out a plan to submit to the Sacred Congregation, we will inform you of this. I imagine that it would envisage your staying at Serra while continuing school, but reporting to Cupertino during vacations and over holidays for special instructions. At any rate, we will keep in touch with you about this program as it is developed.

We are very happy, Tom, that you applied to the novitiate and have been accepted for the novitiate of the Society of Mary. The Brothers have been delighted with you and your presence at Serra. You mean much to the Brothers, and you will be of great help to them.

I would recommend that you continually do some reading of the documents of the Society of Mary. If I can be of further help in this regard, do not hesitate to let me know.

Again, congratulations, Tom. You are in our prayers. Do continue to remember us in yours. May your Easter be a blessed and joyous one.

Sincerely yours in J. M. J.,

000380

Father Bertrand E. Clemens, S. M.

February 27, 1970

The Very Reverend Bertrand Clemens, S.M.
Marianist Provincial Residence
Box 937
Cupertino, California 95014

Very Reverend and dear Father Clemens:

The enclosed transcript of credits is being sent to you at
the request of

REVEREND THOMAS EARL HAVEL.

A transcript of his college credits is being mailed separately
from St. John's College.

Fraternally yours in Christ,

(Rev.) Charles E. Miller, C.M.
Registrar

Hi Tom,
Hope all goes well. God bless
you.
Fraternally,
Charley

000381

C
O
P
Y

February 16, 1970

Reverend Thomas Havel
Serra High School
14830 South Van Ness Avenue
Gardena, CA 90249

Dear Tom,

Just after I had written to you, I received your curriculum vitae. Many thanks for this. I am sure this will come in very handy when we write to Rome for an indult for you.

If you have any trouble in securing any papers for application to the novitiate or have any questions in this regard, and if I can be of help to you, do not hesitate to write to me. I assure you that I am very happy that you are planning to join the Society of Mary. You will be able to contribute much to the Brothers and to the Society.

You are daily in our prayers keep us in yours.

Sincerely yours in J. M. J.,

Father Bertrand E. Clemens, S.M.

000382

February 10, 1970

Reverend Thomas Hovel
Junipero Serra High School
14830 South Van Ness Avenue
Gardena, CA 90249

Dear Tom,

In my recent letter to you, I mentioned that I would bring to the attention of the Provincial Council the fact that it seemed advisable in your case to write to the Sacred Congregation of Religious for an indult concerning yourself and the novitiate, if you formally request a novitiate and this is approved by the council. We had a council meeting yesterday, and I discussed this matter with the council. The council agreed with me on this proposal.

Now, this would entail, Tom, that you would make a formal request to enter the novitiate of the Society of Mary. To do this there are a number of papers that are required. My suggestion would be that you ask Brother Ed Carey, the director, for a set of papers for the novitiate. If he should not have this set of papers which you are to complete and send to us, just let me know, and I can send you a set. The papers are documents that you will be asked to submit to us requesting entrance into the novitiate are: Your formal letter of request to enter the novitiate and in this letter you give the reasons for your desire to enter the Society of Mary; a questionnaire of information about yourself is one of the papers that Brother Ed Carey will give you; then there is required the MMPI psychological test; a medical report is required and this paper can be furnished to you by Brother Ed also; a paper giving your parents consent is required; we would also need a letter from the Archbishop granting you permission to do this and a recommendation from him or someone else in the Diocese; a transcript of your credits from college is also required; if you can get a document showing your ordination this will include automatically other documents which are normally required but which you would not have to get such as baptismal certificate, confirmation certificate, and marriage certificate of your parents; a letter of recommendation by

000383

Reverend Thomas Hovel

Page 2

February 10, 1970

Brother Ed Carey, and finally a passport size photo of yourself. This list of needed documents sound rather formidable, but I am sure once you have the papers needed to aid you in getting this information to us, the real job will not look too difficult. I believe it would be well if you could begin securing these documents soon, for often there are delays which would then hold up the process of acceptance to the novitiate. Once the Provincial Administration has all these documents, then your request is considered in council. If the decision is favorable, then we would immediately write to Rome to secure an indult for you for the novitiate as I described in the previous letter.

In my previous letter I had asked you to send me a curriculum vitae, and I would still appreciate if I could get this from you, Tom. This will help us when eventually we would be writing for the indult, once you are accepted into the novitiate formally.

I am sure that Brother Ed Carey or Brother Jack McNeil could help you in many ways to secure these documents and this information. If there is anything further that I can help you with, do not hesitate to write.

I want to assure you again, that we are very happy that you are planning to request this entrance into the novitiate. We shall look forward to seeing your request. The Brothers at Serra are very fond of you and appreciate all that you are doing for them as a person and as a priest. This is greatly appreciated by all of us. We do hope that you will find religious life and community life among the Marianists most satisfying and beneficial. I am sure that you will. You are daily in our prayers keep us in yours.

Sincerely yours in J. M. J. ,

Father Bertrand E. Clemens, S. M.

000384

February 3, 1970

Reverend Thomas Havel
The Marianists
14830 South Van Ness Avenue
Gardena, California 90249

Dear Tom,

As I mentioned to you when we spoke together at Serra last week, I did consult with Father Joseph Stefanelli concerning your Novitiate. Father Joe made a suggestion which I plan to bring to the Council, and that is, that since you are already an ordained priest, I write to the Sacred Congregation of Religious through our General Administration asking for a very special Novitiate in your case, and to request and indult for this.

I would like to ask the Sacred Congregation that you spend parts of your summers and Christmas and Easter vacations in a formal Novitiate here at Cupertino like you suggested, and live in our community at Serra as you are doing now while still pursuing your studies. This would be exactly what you had suggested yourself. In order to do this, I would appreciate it if you could write to me at your earliest convenience and give me a listing of your previous schooling. The name of the grade school, high school, seminary and information that I could send to the Sacred Congregation. If you could also give me the date of your ordination, by whom, and where you served as a priest, I would pass on all this information to the Sacred Congregation. I am sure that they would want such a curriculum vitae.

We are having a Council meeting next tuesday, and I will bring this to the attention of my council. I do expect the Council will go along with this suggestion. So if I could have this information on you at an early date, I would get off this request to our General Administration and the Sacred Congregation as soon as possible.

000385

Father Thomas Havel
3 February 1970

2

If I have my facts correct, we could expect that you could have two or three weeks free at the beginning of this next summer and two or three weeks towards the end of this next summer free. You would also have the Christmas break of 1970 which would consist of about two or three weeks. Your semester week break would also be about two weeks. I believe you mentioned that you would have the whole summer free of 1971. I believe that such periods of time spent in a formal Novitiate setting of some kind would be acceptable to the Sacred Congregation. I will see what I can do in this regard.

It was good talking with you while I was at Serra. We are very happy that you are with us at Serra, and the Brothers do like you very much and appreciate you. We are very happy that you are thinking of joining the Society of Mary. Keep us in your prayers, Tom. You are in ours.

Sincerely yours in J.M.J.,

Father Bertrand E. Clemens, S.M.

000386

Thomas E. Havel, Jr.

October 12, 1937

Born:
Blue Earth, Minn.

October 27, 1937

Baptized:
Ss. Peter and Paul Catholic Church
Blue Earth, Minn.

May 1, 1944

First Holy Communion:
Ss. Peter and Paul Catholic Church
Blue Earth, Minn.

September 1943 - May 1946

Grammar School:
Blue Earth Public School
Blue Earth, Minn.

September 1946 - May 1948

Grammar School:
St. Margaret Mary's Catholic School
Omaha, Nebr.

September 1948 - December 1949

Grammar School:
St. Cecilia's Catholic School
Omaha, Nebr.

December 1949 - May 1951

Grammar School:
St. Monica's Catholic School
Santa Monica, Calif.

September 1951 - May 1955

High School
St. Monica's Boys' High School
Santa Monica, Calif.

September 1955 - May 1957

Junior Seminary:
Our Lady, Queen of the Angeles
San Fernando, Calif.

September 1958- May 1963

Major Seminary:
St. John's Seminary
Camarillo, Calif.

May 3, 1963

Ordination:
For the Archdiocese of Los Angeles
By: James Cardinal McIntyre
St. Vibiana Cathedral
Los Angeles, Calif.

May 1963 - August 1967

Assistant Pastor:
St. Bernardine of Siena Parish
Woodland Hills, Calif.

August 1967 - August 1969

Assistant Pastor:
St. Philip the Apostle Parish
Pasadena, Calif.

I have a Bachelor of Arts Degree in Philosophy which I received in May of 1960.

000328



Timotheus Manning
Dei et Apostolicae Sedis Gratia
Archiepiscopus Angelorum
in California

Dilecto Nobis in Christo _____ THOMAE E. HAVEL _____

Nos, considerantes tuam in Domino utilitatem, et rationes quas ad hoc Nobis exposuisti, salvis iure praescriptis circa ordinationis tuae titulum, praeviis etiam de tuis natalibus, vita, moribus ac studiis opportunis relationibus et testimoniis, a Nobis mature perpensis et recognitis, et causa novae incardinationis tuae ad Societas Mariae - Marianistae directis, ad tuam petitionem et instantiam, ex Nostra dioecesi Angelorum in California praesentium virtute te exordinamus exordinatumque declaramus. In nomine Patris et Filii et Spiritus Sancti. Amen.

Datum in Civitate Angelorum, sub signo sigilloque Nostris ac cancellarii Nostri subscriptione, anno Domini 1972, die vero 10a mensis Maii.

+ Timotheus Manning

ARCHIEPISCOPUS ANGELORUM IN CALIFORNIA

DE MANDATO REVERENDISSIMI ARCHIEPISCOPI

CANCELLARIUS

000391



Timotheus Manning
Dei et Apostolicae Sedis Gratia
Archiepiscopus Angelorum
in California

Dilecto Nobis in Christo _____ THOMAE E. HAVEL _____

Nos, considerantes tuam in Domino utilitatem, et rationes quas ad hoc Nobis exposuisti, salvis iure praescriptis circa ordinationis tuae titulum, praeviis etiam de tuis natalibus, vita, moribus ac studiis opportunis relationibus et testimoniis, a Nobis mature perpensis et recognitis, et causa novae incardinationis tuae ad _____ Societas Mariae - Marianistae _____ directis, ad tuam petitionem et instantiam, ex Nostra dioecesi Angelorum in California praesentium virtute te exordinamus exordinatumque declaramus. In nomine Patris et Filii et Spiritus Sancti. Amen.

Datum in Civitate Angelorum, sub signo sigilloque Nostris ac cancellarii Nostri subscriptione, anno Domini _____ 1972 _____, die vero _____ 10a _____ mensis _____ Maii _____.

+ Timotheus Manning

ARCHIEPISCOPUS ANGELORUM IN CALIFORNIA

DE MANDATO REVERENDISSIMI ARCHIEPISCOPI

CANCELLARIUS

SOCIETY OF MARY
(Mariamists)
Box 586, Santa Cruz, California

000393

Application for Admission to Novitiate Aspirancy Program (check one)

Please TYPE or PRINT information requested

Name in Full Havel, Thomas E., Jr.
Print (Family Name) (First) (Middle)
 PLEASE PRINT YOUR FULL LEGAL NAME DO NOT USE NICKNAMES

Address 18430 S. Van Ness, Gardena, Calif. 90249 DA 4-4412
Number Street City Zone State Telephone

Date of Birth 1-12-'37 Place of Birth Blue Earth, Minn.
Month Day Year City State

Father's Name in Full: Dr. Thomas E. Havel Mother's Maiden Name: Elizabeth S. Schiltz

Present Address 538 Marguerita, Santa Monica Present Address same

Living? yet Age in Years 59 Religion R. C. Living? Yes Religion R. C.

Nationality American Place of Birth Minn. Nationality American Place of Birth Nebr.

Occupation Doctor Occupation Housewife

Graduate of High School? Montgomery Minn. Graduate of High School? Grand Island, Nebr.
Name of High School Name of High School
Mongomery, Minn. Grand Island, Nebr.
Location of High School Location of High School

Graduate of College? Creighton Graduate of College? St. Catherine's School
Name and Location of College Name and Location of College
Omaha, Nebr. Omaha, Nebr.

Name and Address of Business: 2200 Santa Monica Name and Address of Business (if other than housewife)
Blvd., Santa Monica, Calif. same as above

If parents are deceased, give guardian's name _____ (Address)

(City) (State) (Relationship) (Occupation)

Number of Older Brothers none Younger Brothers 3 Older Sisters none Younger Sisters 1

| • Chronological list of all high schools and colleges attended | Location (City and State) | Date Entered (Month & Year) | Date Left | Month & Year of high school and/or college graduation |
|--|---------------------------|-----------------------------|--------------|---|
| <u>St. Monica's Boys' High</u> | <u>Santa Monica, Ca.</u> | <u>9/'51</u> | <u>5/'55</u> | <u>same</u> |
| <u>St. John's Seminary</u> | <u>Camarillo, Calif.</u> | <u>9/'55</u> | <u>5/'63</u> | <u>5/'59</u> |
| | | | | |
| | | | | |

Parish to which you now belong St. Anthony's 1050 W. 163 rd, Gardena, Ca.
Name Address

Pastor's Name Rev. James E. Hansen Does he know you personally? Yes No

What Priest knows you personally? Msgr. Lawrence O'Leary 1531 W. 9th St.
Name L.A. Calif 91105

Maria Duce!

SOCIETY OF MARY

FORMULA OF TEMPORARY PROFESSION

For the glory of the Most Holy Trinity and
the honor of Mary, for my sanctification
and the salvation of men, I

Thomas Havel

promise to God and vow to observe during
one year chastity, poverty and obedience,
conformably to the Constitutions of the
Society of Mary.

Done at: Danville

Signed: Thomas E. Havel, S.M.

13 August 1978
(Day) (Month) (Year)

000395

HAVEL, Thomas

Maria Duce!

SOCIETY OF MARY

FORMULA OF TEMPORARY PROFESSION

For the glory of the Most Holy Trinity and
the honor of Mary, for my sanctification
and the salvation of men, I

Thomas E. Havel.
promise to God and vow to observe during
one year chastity, poverty and obedience,
conformably to the Constitutions of the
Society of Mary.

Done at: Cupertino

Signed: Thomas E. Havel, S.M.

4 12 '77
(Day) (Month) (Year)

000396

HAVEL, Thomas

Maria Duce!

SOCIETY OF MARY

FORMULA OF TEMPORARY PROFESSION

For the glory of the Most Holy Trinity and
the honor of Mary, for my sanctification
and the salvation of men, I

Thomas Havel
promise to God and vow to observe during
one year chastity, poverty and obedience,
conformably to the Constitutions of the
Society of Mary.

Done at: Santa Barbara

Signed: Thomas E. Havel, S.M.

13 June 1976
(Day) (Month) (Year)

000397

HAVEL, Thomas

Maria Duce!

SOCIETY OF MARY

FORMULA OF TEMPORARY PROFESSION.

For the glory of the Most Holy Trinity and
the honor of Mary, for my sanctification
and the salvation of men, I

Thomas Havel
promise to God and vow to observe during
one year chastity, poverty and obedience,
conformably to the Constitutions of the
Society of Mary.

Done at: Honolulu, Hawaii

Signed: Thomas E. Havel, Jr

7th June 1975
(Day) (Month) (Year)

000398

Maria Duce!

SOCIETY OF MARY

FORMULA OF THE TEMPORARY PROFESSION

For the glory of the Most Holy Trinity, the honor of Mary, the salvation of all men and to follow Christ more closely, I,

Thomas Havel

promise to God and vow to observe during one year Chastity, Poverty and Obedience conformably to the Constitutions of the Society of Mary.

Done at Bethesda, Md.

Signed: Thomas Havel

23 June 1974
(Day) (Month) (Year)

000399

Maria Duce!

SOCIETY OF MARY

FORMULA OF THE TEMPORARY PROFESSION

For the glory of the Most Holy Trinity, the honor of Mary, the salvation of all men and to follow Christ more closely, I,

Thomas Havel

promise to God and vow to observe during one year Chastity, Poverty and Obedience conformably to the Constitutions of the Society of Mary.

Done at Baltimore --

Signed: Thomas E. Havel, A.M.

23rd June 1973
(Day) (Month) (Year)

Maria Duce!

SOCIETY OF MARY

FORMULA OF THE TEMPORARY PROFESSION

For the glory of the Most Holy Trinity, the honor of Mary, the salvation of all men and to follow Christ more closely, I,

Thomas Havel

promise to God and vow to observe during one year Chastity, Poverty and Obedience conformably to the Constitutions of the Society of Mary.

Done at San Damiana - - -

Signed: Thomas Havel

13 August 1972
(Day) (Month) (Year)

000400

J.M.J.

In baptism I was buried with Christ, so that I might live His new life in the power of His Resurrection. This baptism-consecration made me another Christ, Son of Mary. Today, I want to renew this consecration.

I consecrate myself now in the Society of Mary, in order to begin my preparation for profession as a Marianist. I consecrate myself in the Society of Mary in order:

-- to strive together with my fellow Marianists to attain the perfection of charity,

-- to follow Christ more closely through a life conformable to his, a life which was poor, chaste and obedient,

-- to confide myself to Mary, so that under her care, she might render me more conformable to her Son, Jesus Christ,

-- to form an alliance with Mary, the Mother of the Savior and the woman associated in the mystery of salvation, so as to assist her in her mission in the Church of restoring supernatural life to men,

-- to live together with my fellow Marianists in community, so as to praise God in prayer with them, to aid them in attaining a closer union with the Risen Christ, and with them to spread the Kingdom of God to all men by multiplying Christians,

-- and finally, to dedicate my priestly ministry and service to my fellow Marianists and their apostolate.

Through this consecration today, with the aid of the Holy Spirit and our Blessed Mother, I am confident I can live my life in the power of the Risen Christ to the greater glory of the Father and to the greater service of my fellow Marianists and all mankind.

Thomas Havel
(signature)

Feb. 3, 1971
(date)

000901

Record of Test Data

| NAME OF TEST | FORM | DATE GIVEN | TEST SCORE |
|--------------|----------|------------|---------------------------|
| Cal. Reading | Advanced | 12/18/52 | Gr. Pl. 13.7 81% 95 |

Record of Participation in Extra-Curricular Activities

| ACTIVITY | PERIOD |
|----------|--------|
| | |
| | |

Transferred to _____

College Grades Received _____

Sherry Scriber 2/27/70

**SAINT MONICA'S HIGH SCHOOL
SANTA MONICA, CALIFORNIA**

Student's full name Havel, Thomas E. Jr.

Student's address 240 18th. Street
Santa Monica, California

Date of student's birth October 12 1937
MONTH DAY YEAR

Date student entered this school September 14 1951
MONTH DAY YEAR

Student graduated June 19 1955
MONTH DAY YEAR

Number in graduating class 65

Approximate rank in graduating class 3

Student withdrew without graduating _____

Father or Guardian Dr. T. E. Havel MONTH DAY YEAR
Paris St. Monica's

School Year

High Schools Attended

19 51-52 1st Sem. St. Monica's
 2d Sem. Same

| NAME OF SUBJECT | SEM. MARKS | | SEMESTER PERIODS | | 1st Sem. | 2d Sem. |
|-----------------|------------|----|------------------|---------------|----------|---------|
| | 1st | 2d | | | | |
| Religion | A | A | 1 | Days Absent | 1 | 0 |
| English | B | B | 1 | Times Tardy | 0 | |
| Algebra I | B | B | 1 | Citizenship | A | A |
| History | A | A | 1 | Obs. of Rules | | |
| Latin | B | B | 1 | Courtesy | | |
| Hygiene | A | B | 1 | Office Held | | |
| P.E. | A | A | 1 | | | |
| Typing | | C | 1 | | | |

19 52-53 1st Sem. St. Monica's
 2d Sem. Same

| | | | | | | |
|------------|---|---|---|---------------|---|---|
| Religion | A | A | 1 | Days Absent | 0 | 2 |
| English | B | B | 1 | Times Tardy | | |
| Algebra II | B | A | 1 | Citizenship | A | B |
| History II | B | B | 1 | Obs. of Rules | | |
| Latin II | B | B | 1 | Courtesy | | |
| P.E. | B | A | 1 | Office Held | | |
| Typing | | | | | | |

19 53-54 1st Sem. St. Monica's
 2d Sem. Same

| | | | | | | |
|-----------|---|---|---|---------------|---|---|
| Religion | A | A | 1 | Days Absent | 3 | 1 |
| English | B | B | 1 | Times Tardy | 2 | 5 |
| Latin III | C | C | 1 | Citizenship | A | A |
| History | A | A | 1 | Obs. of Rules | | |
| Chemistry | A | A | 1 | Courtesy | | |
| Geometry | A | A | 1 | Office Held | | |

19 54-55 1st Sem. St. Monica's Boys'
 2d Sem. Same

| | | | | | | |
|------------------------|---|---|---|---------------|--|---|
| Religion | A | A | 1 | Days Absent | 0 | 0 |
| English | B | B | 1 | Times Tardy | 0 | 2 |
| Biology | A | A | 1 | Citizenship | A | A |
| Trig. & Solid Geometry | A | A | 1 | Obs. of Rules | | |
| Physics | A | B | 1 | Courtesy | | |
| Civics & Sociology | A | A | 1 | Office Held | AWARDS: | |
| | | | | | Pastor's award for outstanding student in Religion | |

Final Marks: A-Superior, B-Recommended, C-Average, D-Fair, F-Failure.
 Citizenship Medal

LOYOLA UNIVERSITY OF LOS ANGELES - MARYMOUNT COLLEGE
OFFICE OF THE REGISTRAR

Date 3/27/70
Name Harold, Thomas E., Jr
Student's Address 14530 S. Van Ness
Granada, Calif

REQUEST FOR TRANSCRIPT

Currently enrolled? Yes No

If no, date of last attendance

Cost per copy: \$1.00 Paid: \$

Number of copies to be sent 1

Hold for final grades? Yes No

Treasurer's Approval:

Transcript issued:

Print Plainly, the name and address of the institution you wish to receive this transcript.
THIS FORM WILL BE USED FOR MAILING.

Very Rev Bernhard Clemens
Marist Provincial Residence
PO Box 937
Lupertina, Calif 95014

Transcripts will be sent out in turn as requests are received. Requests must be made at least one week before transcript is needed.

MAR 4 1970

000404

LOYOLA UNIVERSITY OF LOS ANGELES - MARYMOUNT COLLEGE
OFFICE OF THE REGISTRAR

Date 2/27/90
Name Havel, Thomas E, JR.
Student's Address 14830 S. VAN NESS
GARDENA, CALIF.

Print Plainly, the name and address of the institution you wish to receive this transcript.
THIS FORM WILL BE USED FOR MAILING.

Very Rev Bertrand Clemens
MARIAIST Provincial Residence
P.O Box 937
Cupertino, Calif 95014

Transcripts will be sent out in turn as requests are received. Requests must be made at least one week before transcript is needed.

REQUEST FOR TRANSCRIPT

Currently enrolled? Yes No

If no, date of last attendance

Cost per copy: \$1.00 Paid: \$ M.C.

Number of copies to be sent 1

Hold for final grades? Yes No

Treasurer's Approval:

Transcript issued:

000105

000406

CREATE IN ME A CLEAN HEART O GOD,
AND PUT A NEW AND RIGHT SPIRIT WITHIN ME

PSALM 51:10

PSALM SCAPES
Pictorial by Catherine
Litho in U.S.A. 8445465
© Concordia Publishing House 1978

Closing Song - Praise the Lord, My Soul
by John Foley, S.J.

1. Praise the Lord, my soul,
2. Bless the Lord, my soul,
3. Mer - ci - ful and kind,
4. Glo - ry to our God,

1. let fire and rain give praise to Him,
2. let all I am give praise to Him;
3. He knows our ways, He knows we're dust;
4. let all that is give praise to Him;

1. give praise to Him, Who is mer - ci - ful,
2. and not for - get He is kind, He for -
3. and like the flow - ers that flour - ish, we
4. give praise to Him, all you crea - tures who

1. slow to judge; bless the
2. gives our sins; bless the
3. soon must die; bless the
4. live His love; bless the

1. Lord, O my soul,
2. Lord, O my soul,
3. Lord, O my soul,
4. Lord, O my soul,
1.1.2.3.

4. soul, bless the Lord, O my

soul,

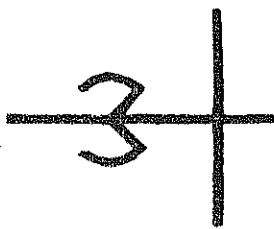

CELEBRATION OF MARIANIST
RELIGIOUS PROFESSION OF

Reverend Thomas Havel, S.M.

Sunday, August 10, 1980

11:00 a.m.

Provincialate Chapel - Cupertino

INTRODUCTORY RITES

Entrance Antiphon - A Banquet Is Prepared
by John Kavanaugh, S.J.

A ban-quet is pre-pared with my cup run-ning
o-ver; my head is a-noint-ed with oil.

1. The Lord is my shepherd; I shall want nothing.
He leads me to rest in green fields;
He leads me always on the path of fidelity
To waters of cool refreshment.
2. If I have to wander through the valleys of darkness,
No evil at all will I fear.
He shall be present, guiding with kindness;
His shepherd's staff giving me comfort.
3. A banquet is prepared with my cup running over;
My head is anointed with oil.
Strength and forgiveness are always with me,
At peace in the house of the Lord.

Greeting and Welcome

In the name of the Father, and of the Son, and
of the Holy Spirit.

AMEN.

1. grown, let me sow Your love.
2. fear, let me sow Your faith.
3. here, let me sow Your joy.
4. soled, than to help con-sole,
5. less, than to give love free,
6. Thee, You've for-giv-en me;

1. Where there's in-jury, Lord, let for
2. in this world's des-pair, give me
3. When the dark-ness nears, may Your
4. less be un-der-stood than to
5. just to give in Thee, just re-
6. for to die in Thee is e-

1. give-ness be my sword, Lord,
2. hope in You to share, Lord,
3. light dis-pel our fears, Lord,
4. un-der-stand Your good, Lord,
5. ceiv-ing from Your tree, Lord,
6. ter-nal life to me, Lord,

1. make me a means of Your peace.
2. make me a means of Your peace.
3. make me a means of Your peace.
4. make me a means of Your peace.
5. make me a means of Your peace.
6. make me a means of Your peace.

Holy, Holy - (recited)

Holy, holy, holy Lord, God of power and might,
heaven and earth are full of your glory.
Hosanna in the highest.
Blessed is he who comes in the name of the Lord.
Hosanna in the highest.

Eucharistic Acclamation - (sung)

When we eat this bread and drink this cup,
we proclaim your death, Lord Jesus,
until you come in glory.

Amen - (sung)

The Lord's Prayer - (sung)

Communion Song - Peace Prayer
by John Foley, S.J.

Congregation

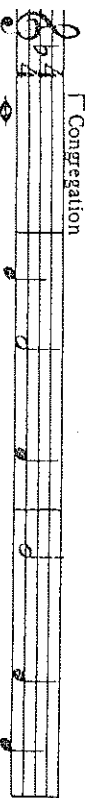

1. Lord, make me 2 means of Your
2. Lord, make me 2 means of Your
3. Lord, make me 2 means of Your
4. Lord, grant me to seek and to
5. Lord, grant me to seek and to
6. Lord, grant me to seek and to

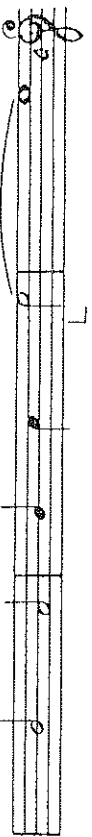

1. peace. Where there's ha - tred
2. peace. Where there's doubt and
3. peace. Where there's sad - ness
4. share: to less to be con -
5. share: to re - ceive love
6. share: to for - give in

The grace and peace of God our Father and the
Lord Jesus Christ be with you.
BLESSED BE GOD, THE FATHER OF OUR LORD JESUS
CHRIST.

Renewal of Baptism

We renew together our first commitment,
made by water and the Holy Spirit.

Gloria

Glory to God in the highest,
and peace to his people on earth.
Lord God, heavenly King,
almighty God and Father,
we worship you, we give you thanks,
we praise you for your glory.
Lord Jesus Christ, only Son of the Father,
Lord God, Lamb of God,
you take away the sin of the world:
have mercy on us;
you are seated at the right hand of the Father:
receive our prayer.
For you alone are the Holy One,
you alone are the Lord,
you alone are the Most High,
Jesus Christ,
with the Holy Spirit,
in the glory of God the Father.

AMEN.

Rite of Peace

General Intercessions

THE LITURGY OF THE EUCHARIST

Offer tory - I Lift Up My Soul
by Tim Manion

To You, Yah-weh, I lift up my

soul, O my God.

To You, Yah-weh, I lift up my

soul, O my God.

1. Yahweh, show Your ways to me.
Teach me Your paths
And keep me in the ways of Your truth,
For You are the God that saves me.
2. The Lord is so good, so holy,
Sinners find the way
And in all that is right He guides the humble;
The poor He leads in His pathways.
3. All day long I hope in Your goodness.
Remember Your love,
The love that You promised long ago,
And the kindness that You gave from of old.

Opening Prayer

Let us pray.

God our Father,
 you have caused the grace of baptism
 to bear such fruit in your servants,
 that they now strive to follow your Son
 more closely.
 Let them rightly aim
 at truly evangelical perfection
 and increase the holiness
 and apostolic zeal of your Church.
 We ask this through our Lord Jesus Christ,
 your Son,
 who lives and reigns with you
 and the Holy Spirit, one God,
 forever and ever.

AMEN.

THE LITURGY OF THE WORD

First Reading from the book of Wisdom
 18:6-9

Just as you struck our enemies,
 you made us glorious by calling
 us to you.

Responsorial - Be Not Afraid
 by Bob Dufford, S.J.

1. You shall cross the barren desert,
 But you shall not die of thirst.
 You shall wander far in safety
 Though you do not know the way.
 You shall speak your words in foreign lands
 And all will understand.
 You shall see the face of God and live.

Brothers:

With the blessing of your family and the witness of this Christian community, we welcome you into the Society of Mary. We require you to live your life in the spirit of our Founder, William Joseph Chaminate. Be, therefore, a servant of God's Word, obedient to the call you have heard, and loving toward the persons you will encounter.

The gold ring is a symbol of tradition and fidelity in the Society of Mary, signifying consecration to the Lord through our Blessed Mother.

Let us pray.

Father, bless Tom who will wear this ring. May this symbol of consecration be a constant reminder to Tom that our life is a response to the call of Christ, a call to share more deeply in His life, death and resurrection. May this ring be a sign of your covenant with our Brother and a symbol to him of the alliance he makes with Mary and her Society. We pray in Jesus' name, he who lives and reigns forever and ever.

AMEN.

The profession of perpetual vows is made in these words:

FOR THE GLORY OF THE MOST HOLY TRINITY,
THE HONOR OF MARY,
THE SALVATION OF THE WORLD,
AND TO FOLLOW CHRIST,
I PROMISE TO GOD AND VOW TO OBSERVE
DURING MY WHOLE LIFE
CHASTITY, POVERTY, OBEDIENCE AND STABILITY
CONFORMABLY TO THE RULE OF LIFE
OF THE SOCIETY OF MARY.

Be not a - fraid. I go be -
fore you al - ways. Come fol - low Me. and
I will give you rest.

2. If you pass through raging waters in the sea
You shall not drown.
If you walk amid the burning flames,
You shall not be harmed.
If you stand before the pow'r of hell
And death is at your side,
Know that I am with you through it all.
3. Blessed are your poor,
For the kingdom shall be theirs.
Blest are you that weep and mourn,
For one day you shall laugh.
And if wicked men insult and hate you
All because of Me,
Blessed, blessed are you!

Second Reading from the Letter to the Hebrews
11:1-2, 8-19

We will look for the city
designed and built by God.

Gospel Acclamation (sung)

Third Reading from the Gospel according to Luke
12:32-48

See that you are prepared.

Homily - Father Stefanelli

THE LITURGY OF RELIGIOUS PROFESSION

Fr. Joe: Tom, by water and the Holy Spirit you have already been consecrated to God's service: are you resolved to unite yourself more closely to him by the new bond of religious profession?

Fr. Tom: I am.

Fr. Joe: Are you resolved to strive steadfastly for perfection in the love of God and of your neighbor by living the Gospel with all your heart and keeping the Rule of Life of the Society of Mary?

Fr. Tom: I am.

Fr. Joe: Tom, will you, through the love of Jesus, consecrate yourself with your whole being to him, and henceforth fulfill the service of God in the Society of Mary in communion with your brothers?

Fr. Tom: I will.

Fr. Joe: Will you, in order to give yourself completely to the love of Christ and to live the common life, remain celibate?

Fr. Tom: I will.

Fr. Joe: Will you, in order that we may be of but one heart and one soul, and, that unity of service may be fully realized, discern the will of God as manifested through the Constitutions, the directives of leadership, and the decisions made in community?

Fr. Tom: I will.

At this point, the assembly will stand.

Fr. Joe: Members of the Christian community, here gathered, you have heard Tom express his intentions. What is your wish for him?

All: TOM, WE DESIRE THAT YOU WILL CONTINUE TO GIVE OF YOURSELF IN THE LIFE YOU HAVE CHOSEN. WE PRAY THAT THE GIFT OF LIFE YOU BRING TO OTHERS MAY ALWAYS WITNESS THE GIFT OF LOVE YOU HAVE RECEIVED FROM GOD. WE WILL CONTINUE TO HELP YOU GROW IN FAITH.

Fr. Tom then dialogues with his Brothers.

Fr. Tom: Brothers, you have heard me share with this community my call from the Lord and my desire to respond to Him. Will you accept me as I am, full of hopes and aspirations, limitations and weaknesses? Will you pledge to me your support and assist me in fulfilling my hopes for humanity?

000407

CREATE IN ME A CLEAN HEART O GOD
AND PUT A NEW AND RIGHT SPIRIT WITHIN ME
PSALM 51:10

PSALM/SCAPES
Illustrated by Camarique
Litho in USA 64-5485
© Concordia Publishing House 1978

Closing Song - Praise the Lord, My Soul
by John Foley, S.J.

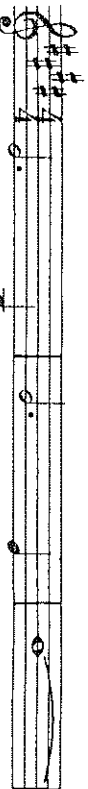

1. Praise the Lord, my soul,
2. Bless the Lord, my soul,
3. Mer - ci - ful and kind,
4. Glo - ry - to our God,

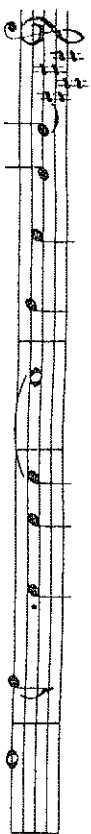

1. let fire and rain give praise to Him,
2. let all I am give praise to Him;
3. He knows our ways, He knows we're dust;
4. let all that is give praise to Him;

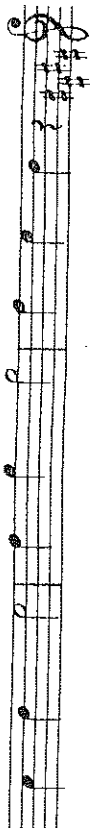

1. give praise to Him, Who is mer - ci - ful,
2. and not for - get He is kind, He for -
3. and like the flow - ers that flour - ish, we
4. give praise to Him, all you crea - tures who



1. slow to judge; bless the
2. gives our sins; bless the
3. soon must die; bless the
4. live His love; bless the



1. Lord, O my soul,
2. Lord, O my soul,
3. Lord, O my soul,
4. Lord, O my soul,



4. soul, bless the Lord, O my



soul.

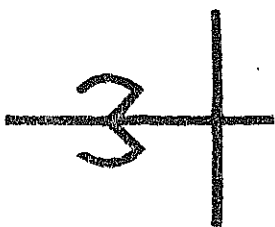

CELEBRATION OF MARIANIST
RELIGIOUS PROFESSION OF

Reverend Thomas Havel, S.M.

Sunday, August 10, 1980

11:00 a.m.

Provincialate Chapel - Cupertino

INTRODUCTORY RITES

Entrance Antiphon - A Banquet Is Prepared
by John Kavanaugh, S.J.

A ban-quet is pre-pared with my cup run-ning
o-ver; my head is a-noint-ed with oil.

1. The Lord is my shepherd; I shall want nothing.
He leads me to rest in green fields;
He leads me always on the path of fidelity
To waters of cool refreshment.
2. If I have to wander through the valleys of darkness,
No evil at all will I fear.
He shall be present, guiding with kindness;
His shepherd's staff giving me comfort.
3. A banquet is prepared with my cup running over;
My head is anointed with oil.
Strength and forgiveness are always with me.
At peace in the house of the Lord.

Greeting and Welcome

In the name of the Father, and of the Son, and
of the Holy Spirit.

AMEN.

1. grown, let me sow Your love.
2. fear, let me sow Your faith.
3. here, let me sow Your joy.
4. soled than to help con-sole,
5. less than to give love free,
6. Thee, You've for-giv-en me;

1. Where there's in-jury, Lord, let for
2. In this world's des-pair, give me
3. When the dark-ness nears, may Your
4. less be un-der-stood than to
5. just to give in Thee, just re-
6. for to die in Thee is e-

1. give-ness be my sword, Lord,
2. hope in You to share, Lord,
3. light dis-pel our fears, Lord,
4. un-der-stand Your good, Lord,
5. evil-ing from Your tree, Lord,
6. ter-nal life to me, Lord,

1. make me a means of Your peace.
2. make me a means of Your peace.
3. make me a means of Your peace.
4. make me a means of Your peace.
5. make me a means of Your peace.
6. make me a means of Your peace.

Holy, Holy - (recited)

Holy, holy, holy Lord, God of power and might,
Heaven and earth are full of your glory.
Hosanna in the highest.
Blessed is he who comes in the name of the Lord.
Hosanna in the highest.

Eucharistic Acclamation - (sung)

When we eat this bread and drink this cup,
We proclaim your death, Lord Jesus,
Until you come in glory.

Amen - (sung)

The Lord's Prayer - (sung)

Communion Song - Peace Prayer
by John Foley, S.J.

[Congregation]



1. Lord, make me a means of Your
2. Lord, make me a means of Your
3. Lord, grant me to seek and to
4. Lord, grant me to seek and to
5. Lord, grant me to seek and to
6. Lord, grant me to seek and to

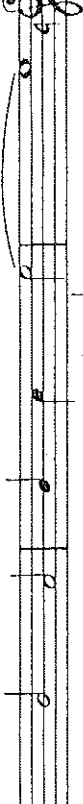

1. peace: _____ Where there's ha - tred
2. peace: _____ Where there's doub - t
3. peace: _____ Where there's sad - ness
4. share: _____ less to be con -
5. share: _____ to re - ceive love
6. share: _____ to for - give in

The grace and peace of God our Father and the
Lord Jesus Christ be with you.

BLESSED BE GOD, THE FATHER OF OUR LORD JESUS
CHRIST.

Renewal of Baptism

We renew together our first commitment,
made by water and the Holy Spirit.

Gloria

Glory to God in the highest,
and peace to his people on earth.
Lord God, heavenly King,
almighty God and Father,

we worship you, we give you thanks,
we praise you for your glory.

Lord Jesus Christ, only Son of the Father,
Lord God, Lamb of God,
you take away the sin of the world:

have mercy on us;
you are seated at the right hand of the Father:
receive our prayer.

For you alone are the Holy One,
you alone are the Lord,
you alone are the Most High,
Jesus Christ,

with the Holy Spirit,
in the glory of God the Father.

AMEN.

Opening Prayer

Let us pray.

God our Father,
you have caused the grace of baptism
to bear such fruit in your servants,
that they now strive to follow your Son
more closely.
Let them rightly aim
at truly evangelical perfection
and increase the holiness
and apostolic zeal of your Church.
We ask this through our Lord Jesus Christ,
your Son,
who lives and reigns with you
and the Holy Spirit, one God,
forever and ever.

AMEN.

THE LITURGY OF THE WORD

First Reading from the book of Wisdom
18:6-9

Just as you struck our enemies,
you made us glorious by calling
us to you.

Responsorial - Be Not Afraid
by Bob Dufford, S.J.

1. You shall cross the barren desert,
But you shall not die of thirst.
You shall wander far in safety
Though you do not know the way.
You shall speak your words in foreign lands
And all will understand.
You shall see the face of God and live.

Rite of Peace

General Intercessions

THE LITURGY OF THE EUCHARIST

Offertory - I Lift Up My Soul
by Tim Manion

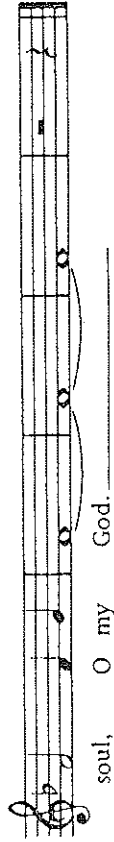
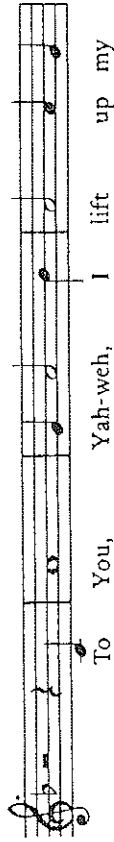
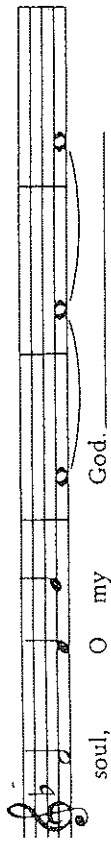
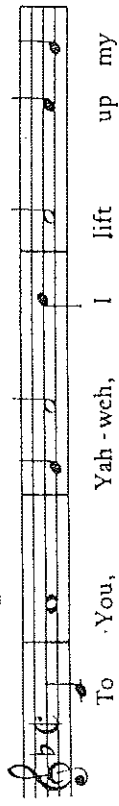

1. Yahweh, show Your ways to me.
Teach me Your paths
And keep me in the ways of Your truth,
For You are the God that saves me.
2. The Lord is so good, so holy,
Sinners find the way
And in all that is right He guides the humble;
The poor He leads in His pathways.
3. All day long I hope in Your goodness.
Remember Your love,
The love that You promised long ago,
And the kindness that You gave from of old.

Brothers:

With the blessing of your family and the witness of this Christian community, we welcome you into the Society of Mary. We require you to live your life in the spirit of our Founder, William Joseph Chaminate. Be, therefore, a servant of God's Word, obedient to the call you have heard, and loving toward the persons you will encounter.

The gold ring is a symbol of tradition and fidelity in the Society of Mary, signifying consecration to the Lord through our Blessed Mother.

Let us pray.

Father, bless Tom who will wear this ring. May this symbol of consecration be a constant reminder to Tom that our life is a response to the call of Christ, a call to share more deeply in His life, death and resurrection. May this ring be a sign of your covenant with our Brother and a symbol to him of the alliance he makes with Mary and her Society. We pray in Jesus' name, he who lives and reigns forever and ever.

AMEN.

The profession of perpetual vows is made in these words:

FOR THE GLORY OF THE MOST HOLY TRINITY,
THE HONOR OF MARY,
THE SALVATION OF THE WORLD,
AND TO FOLLOW CHRIST,
I PROMISE TO GOD AND VOW TO OBSERVE
DURING MY WHOLE LIFE
CHASTITY, POVERTY, OBEDIENCE AND STABILITY
CONFORMABLY TO THE RULE OF LIFE
OF THE SOCIETY OF MARY.

Be not _____ a - fraid. I go and

fore you al - ways. Come fol - low Me, _____ and

I will give you rest. _____

2. If you pass through raging waters in the sea
You shall not drown.
If you walk amid the burning flames,
You shall not be harmed.
If you stand before the power of hell
And death is at your side,
Know that I am with you through it all.
3. Blessed are your poor,
For the kingdom shall be theirs.
Blest are you that weep and mourn,
For one day you shall laugh.
And if wicked men insult and hate you
All because of Me,
Blessed, blessed are you!

Second Reading from the letter to the Hebrews
11:1-2,8-19

We will look for the city
designed and built by God.

Gospel Acclamation (sung)

Third Reading from the Gospel according to Luke
12:32-48

See that you are prepared.

Homily - Father Stefanelli

THE LITURGY OF RELIGIOUS PROFESSION

Fr. Joe: Tom, by water and the Holy Spirit you have already been consecrated to God's service: are you resolved to unite yourself more closely to him by the new bond of religious profession?

Fr. Tom: I am.

Fr. Joe: Are you resolved to strive steadfastly for perfection in the love of God and of your neighbor by living the Gospel with all your heart and keeping the Rule of Life of the Society of Mary?

Fr. Tom: I am.

Fr. Joe: Tom, will you, through the love of Jesus, consecrate yourself with your whole being to him, and henceforth fulfill the service of God in the Society of Mary in communion with your brothers?

Fr. Tom: I will.

Fr. Joe: Will you, in order to give yourself completely to the love of Christ and to live the common life, remain celibate?

Fr. Tom: I will.

Fr. Joe: Will you, in order that we may be of but one heart and one soul, and, that unity of service may be fully realized, discern the will of God as manifested through the Constitutions, the directives of leadership, and the decisions made in community?

Fr. Tom: I will.

At this point, the assembly will stand.

Fr. Joe: Members of the Christian community, here gathered, you have heard Tom express his intentions. What is your wish for him?

All:

TOM, WE DESIRE THAT YOU WILL CONTINUE TO GIVE OF YOURSELF IN THE LIFE YOU HAVE CHOSEN. WE PRAY THAT THE GIFT OF LIFE YOU BRING TO OTHERS MAY ALWAYS WITNESS THE GIFT OF LOVE YOU HAVE RECEIVED FROM GOD. WE WILL CONTINUE TO HELP YOU GROW IN FAITH.

Fr. Tom then dialogues with his Brothers.

Fr. Tom: Brothers, you have heard me share with this community my call from the Lord and my desire to respond to Him. Will you accept me as I am, full of hopes and aspirations, limitations and weaknesses? Will you pledge to me your support and assist me in fulfilling my hopes for humanity?

RENEWAL OF CONSECRATION

1. Baptismal promises renewed
2. Renewal of Vows - Fr. Havel
3. Family of Mary - renewal of consecration

O LORD OUR GOD, IN ORDER TO REDEEM ALL MEN AND WOMEN AND LEAD THEM TO YOURSELF, YOU SENT THEM YOUR BELOVED SON WHO WAS MADE MAN AND BORN OF THE VIRGIN MARY.

GRANT THAT WE MAY BE FORMED BY HER IN THE IMAGE OF HER FIRST-BORN SON, AND HELP US PARTICIPATE IN THE LOVE OF CHRIST FOR HIS MOTHER AND HER APOSTOLIC MISSION.

RATIFY THE CONSECRATION THAT WE HAVE MADE WITH HER. MAY OUR DEVOTEDNESS EXTEND HER MATERNAL CHARITY ON EARTH AND PROMOTE THE GROWTH OF THE CHURCH, THE BODY OF YOUR SON, JESUS CHRIST AND THE GROWTH OF THE FAMILY OF MARY, HER INSTRUMENT.

WE MAKE OUR CONSECRATION THROUGH MARY AND CHRIST OUR LORD. AMEN



000408



The Lord
is my shepherd;

In Loving Memory of
Thomas E. Havel, Sr.

Entered This Life
July 15, 1911

Departed This Life
January 23, 1989

Funeral Services
Rosary/Catholic Prayer Service
Wednesday, January 25, 1989
8:00 P.M.
McCune Garden Chapel

Interment
Holy Redeemer Cemetery
Montgomery, Minnesota

Arrangements By
McCune Garden Chapel
212 Main Street
Vacaville, California

Father of Rev. Thomas E. Havel, SM

I shall not want.

He maketh me to lie down in green pastures:

He leadeth me beside the still waters.

He restoreth my soul: He leadeth me in the
paths of righteousness for His name's sake.

Yea, though I walk through the valley of the
shadow of death, I will fear no evil:

for Thou art with me;

Thy rod and Thy staff they comfort me.

Thou preparest a table before me

in the presence of mine enemies:

Thou anointest my head with oil;

my cup runneth over.

Surely goodness and mercy shall follow me

all the days of my life:

and I will dwell in the house of the Lord

forever.

The Twenty-third Psalm

HAVAL
Tom Hall, S.M., M.D.
Georgetown - probably
the M.D. in the S.M.

Was an American priest - LA -
for long - ordained in 1963
got to know Brothers at Conga
Park - decided to join S.M.

Fr. Clemens - very enthusiastic
started p.m. at Loyola in
L.A. in 1969 - 1971 - accepted
at Georgetown

Starting internship at LA
County / USC Medical Ctr.
LAC / USC / MC - beginning
residency in fall of 1976
(hopefully internal medicine)

Reconcile careers

Maximists not just
educators - universal
apostolate - go where needed

Priest-doctor ^{would serve SM's} & ^{first} primary
health care apostolate -
would form a team
of other SM's (nurse para
medics) etc and live as
a community where we
are most needed:

- 1 - ghettos
- 2 - migrant workers
- 3 - Indian reservations

"Never lose a patient"
one way or another.
If he can't cure the
body, he can help the
soul

Born in Miss. - St. John
Seminary in Camilla -
37 years old -

In L.A. was an asst pastor
in Woodland Hills & Pasadena,
also a Newman Chaplain,

Hawaii - visit Maccanist
community, meet Brooker
here; make annual address

Been here June 2 - June 7

5172
EGG

000410



The President and Faculty
of
Georgetown University
request the honor of your presence
at the
Commencement Exercises
of the
School of Medicine
Georgetown University
Saturday afternoon, the twenty-fourth of May
Nineteen hundred and seventy-five
at three-thirty o'clock

GEORGETOWN UNIVERSITY

School of Medicine

COMMENCEMENT ANNOUNCEMENT

SATURDAY, MAY 24, 1975 **000411**

1:30 P.M.—MASS OF CELEBRATION (DAHLGREN CHAPEL)

REV. LEO P. MONAHAN PRINCIPAL CELEBRANT

3:30 P.M.—COMMENCEMENT EXERCISES (HEALY LAWN)

RECEPTION TO FOLLOW ON WHITE-GRAVENOR LAWN

In Case Of Inclement Weather, Outdoor Events Will Be Held In The
McDonough Gymnasium

760 1000

CURIA GENERALIZIA DEI MARIANISTI
VIA LATINA, 82
00179 ROMA - ITALIA

The Procurator General wishes to acknowledge receipt of
the papers regarding the request for dispensation ^{from the} ~~of vows~~
(and laicization) of obligation of priestly ordination
of THOMAS E. HAVEL
and informs you that the case is under process, in the Holy See
(Congregatio de Cultu Divino et Disciplina Sacram.)
Roma, Sept 15, 1977

E.T.
Fraternally in Chr

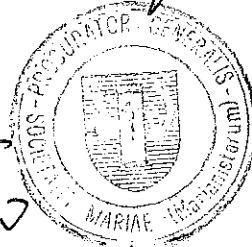

000412

His Holiness Pope John Paul II
The Vatican

Most Holy Father,

Recognizing the gravity of this request but relying on Your compassion and forgiveness, I submit this petition. With this petition I humbly request a dispensation from the obligations connected with the priesthood, religious life and from celibacy. Unfortunately, long ago I abandoned the priestly and religious life. Now I live a life from which I cannot withdraw, but I do wish to sanate this life and live as a Catholic layman in union with the Church.

For most of my life I had wanted to be a physician. In my family and among my relatives are many physicians and health care providers (e.g., my father, uncle and brother are physicians and my mother and two aunts are nurses). As a child and in grammar school I thought of becoming a physician. But, in late grammar school and toward the end of high school, I believed I wanted to be a priest. For the next eight years I studied for the priesthood and was ordained on May 1, 1963. For the next six years I was active as a priest in parish ministry. Even during this time I continued to remain interested in medicine. I requested to become a teacher in biology which was denied. In my last parish assignment, I participated in an ecumenical founding of a Free Clinic to provided medical care to the indigent in our community. At this time in 1969, after much soul searching, I determined to leave the priesthood and pursue a course of studies in medicine.

At this time of crisis, I shared my thoughts with a friend who was a brother in the Society of Mary (Marianists). He encouraged me to talk to his superiors. These superiors were looking to develop a healthcare apostolate within their Province. They generously accepted me into the Society and allowed me to pursue a medical school education. The Society obtained from the Holy See dispensations from novitiate and to attend medical school. I started immediately to attend premedical classes and then medical school. In hindsight, it might have been better to have been grounded in the priesthood and religious life by attending novitiate and living in community for an extended time; but such a expectation might have hastened my departure from priesthood and religious life.

000413

Over the last twenty nine years, I have lived more outside than inside community and religious life. Gradually, I have fallen away from living a priestly life or performing priestly duties until for the last nine years, I have been living a functioning solely as a physician and not identified as a priest. I did not live in community while in medical school (1971-1975). Again I lived outside of community for four years (1981-1985) Finally, I moved out of community permanently in 1988. I have been living as a layman ever since then.

During this time I gradually fell away from living a priestly spiritual life. And I stopped functioning as a priest. I am presently so out of touch with the life of a priest, that I don't have the ability nor the sustaining interest to obtain the knowledge and overcome the multiple obstacles to a return to the life of a priest and religious.

In 1980 I became a treating psychiatrist and later a Medical Director of a Public Psychiatric Hospital. In 1984 to the present, I have been the Medical Directory of Psychiatry in a Community Hospital. In addition to both these positions, I have had an on going private psychiatric practice. My medical profession has been the focus of my interest and passion for the past eighteen years. As a consequence, I believe it morally impossible to leave the practice of medicine even to return to the priesthood.

Thank you for considering my petition. And I humbly ask that you grant it so that I can live a life in full union with the Church and the Sacraments.

Sincerely,

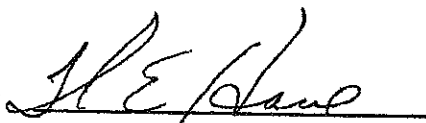
Thomas E. Havel

Date: 6/12/97

000414

Woman says priest molested her often when she was young

ACCUSATION, from Page 1B
question becomes one of proof. What can they prove?"

Asked if his client denies the charges, Hinshaw replied, "I don't think it's appropriate to try it in the newspaper."

Havel could not be contacted. He has remained at his job running the 34-bed psychiatric unit since the lawsuit was filed Nov. 3. Neilson Buchanan, chief executive officer of the publicly owned hospital, declined comment through a spokeswoman.

The Rev. John Bolin, provincial superior of the Marianist Province of the Pacific, to which Havel belongs, said lawyers advised him not to comment.

In a telephone interview, Neuman, now 34, said she sought counseling from the priest for teen-age problems, such as wanting peer acceptance. She said the sexual contact started gradually. "First he would just say, 'I want to hug you,'" she said. Eventually they graduated to kissing, and finally, to sodomy and failed attempts at intercourse, Neuman said.

The suit charges that Havel told Neuman that "the sexual acts they engaged in together would be good for her" and that he blamed her for being a "temptress" at age 13.

"Especially when we got more and more involved, he said it would help me, and he told me not to tell anyone about this," she said.

Neuman said she was in love with the priest, and she hoped they would marry, feelings she expressed in a diary she wrote in code.

"Here's this 13-year-old kid being molested and thinks she's in love with him," said Neuman's attorney, M. [redacted] of Pasadena. The diary is "quite graphic. Usually whenever she sees him she ends up with this terrible little plaintive, 'I love him. I love him.'"

Neuman said her encounters with Havel continued even when he left Pasadena to attend medical school at Georgetown University in Washington. She was 16 at the time. "I guess he got into town to visit his family, but would call me, and we would arrange to get together," she said.

Whether Neuman walked in during one of the visits, Havel's lawyer said, she is not sure. "I don't know if she was in on the date, and she did in a closet for a long time," he said. Neuman said. Other times their encounters would take place in the open spaces of the Santa Monica Mountains, she said.

Neuman said their sexual relationship continued until she was 18 and a student at the University of California, Los Angeles. "I finally ended it," Neuman said. "I wrote him a letter when I was 19."

She's unable to form a permanent attachment to any man that would be marriageable. 7

— M. Patricia Morrison
alleged victim's attorney

sophomore. I said, 'Don't call me when you get into town.'"

Despite her parents' shock when she told them about 15 years ago of her alleged encounters with the priest, the family took no action, Neuman said. Her father, who has a sister and an aunt who are nuns and an uncle who is a priest, "was furious" at Havel.

Havel, 51, has been on El Camino Hospital's staff since 1982 and been medical director of the psychiatric unit for three years, said Jean Altman, the hospital's public relations director.

Neuman said she realized through three years of psychotherapy how the alleged molestation had devastated her, which is why it took her so long to file the suit.

"I've been depressed my whole life," Neuman said. "When I finally discovered in my therapy that what I had been doing wasn't good for me and I wasn't to blame, I was totally enraged and I've been super-depressed since then."

Never married

She has never married. That's one of the allegations, her attorney said. "She's unable to form a permanent attachment to any man that would be marriageable."

Neuman has been unable to hold a steady job as an adult, working as a cook, a waitress, a dental technician, a waitress, a teacher, a French teacher. She graduated from Loyola University Law School in Los Angeles in 1985 but has failed the bar exam twice. She works as a law clerk for her attorney.

Neuman said she was sexually abused by Havel from the time she was 13 until she was 18. "I think the archdiocese is absolutely wrong to make any person they can get their hands on take a part of charity," Morrison said. Also named in the suit are the Marianist fathers and the Archdiocese of Los Angeles.

"I think the archdiocese is absolutely wrong to make any person they can get their hands on take a part of charity," Morrison said.

000415